

Village of Maple Heritage Conservation District Plan 2007

Volume 3



Acknowledgements

The Village of Maple Heritage Conservation District Plan 2006 is the culmination of a great deal of interest and effort by local residents, municipal staff, Heritage Vaughan and Council. All had one objective in common – the desire to develop a plan that will help to ensure the conservation of Maple’s heritage resources and unique character for the enjoyment of future generations.

VILLAGE OF MAPLE HERITAGE CONSERVATION DISTRICT PLAN 2006

This is one of three documents dealing with the Village of Maple Heritage Conservation District.

Table of Contents

User Guide_____	
Acknowledgements_____	i
Table of Contents_____	ii

Part A District Overview

1.0 Introduction

1.1 The Heritage Conservation District Concept_____	3
1.2 Background of the District Plan_____	4
1.3 The District Documents_____	7
1.3.1 Unity of the District Documents_____	7

2.0 Heritage Character and Heritage Statements

2.1 Heritage Resources_____	8
2.2 Statement of Heritage Value _____	9
2.3 Statement of Heritage Attributes_____	9
2.4 Statement of Objectives in Designating the District _____	9
2.4.1 Overall Objective_____	9
2.4.2 Objectives for Heritage Buildings_____	10
2.4.3 Objectives for Non-heritage Buildings_____	10
2.4.4 Objectives for Landscape/Streetscape_____	10
2.4.5 Objectives for New Development_____	10
2.4.6 Objectives for Community Support_____	10
2.4.7 Objectives for Business/Tourism_____	10

3.0 Review and Interpretation

3.1	Review of Activities in the District	11
3.1.1	Activities Subject to Review	11
3.1.2	Activities Exempt from Review	11
3.2	Contexts for Interpretation	11

Part B District Policies

4.0 District Policies—Buildings and Sites

4.1	Overview	14
4.2	Heritage Buildings	15
4.2.1	Conservation of Heritage Buildings	16
4.2.2	Alterations and Additions to Heritage Buildings	17
4.2.3	Relocation of Heritage Buildings	18
4.2.4	Demolition of Heritage Buildings	18
4.2.5	Salvage of Historic Building Materials and Features	19
4.2.6	Uses of a Heritage Building	19
4.3	Non-heritage Buildings	20
4.3.1	Additions and Alterations	20
4.3.2	Design Approach	20
4.3.3	Demolition of Non-heritage Buildings	20
4.4	New Residential Buildings	21
4.4.1	Design Approach	21
4.5	Landscapes	22
4.5.1	Landscape Treatment	22
4.5.2	Trees and Shrubs	22
4.5.3	Fences	22
4.6	Commercial Core	23
4.6.1	Design Approach	23
4.6.2	Commercial Signage	24
4.6.3	Commercial Awnings	24
4.6.4	Commercial Patios	24
4.6.5	Commercial Parking Lots	24

5.0 District Policies—Streetscape and Infrastructure

5.1	Overview	25
5.2	Roads, Curbs, and Municipal Services	25
5.3	Sidewalks and Boulevards	26
5.4	Street Furniture and Pedestrian Amenities	27
5.5	Streetlights and Utility Wires	27
5.6	Public Signage	28
5.7	Vegetation	29

6.0 District Policies—Special Areas and Projects

6.1	Public Awareness	30
6.1.1	Communications	30
6.1.2	Education	31

7.0 Municipal Policies

7.1	Overview	32
7.2	Recognizing the Heritage District Plan	32
7.3	Land Use in the District	33
7.4	Land Severance and Minor Variances	34
7.5	Site Plan Control	35
7.6	Signage By-law	36
7.7	Demolition Control	37
7.8	Heritage Easements	37
7.9	Tax Measures	38
7.10	Grants and Loans	38
7.11	Tree Preservation	39
7.12	Community Improvement Area	39

Part C Implementing the District

8.0 Implementation

8.1	Overview	42
8.2	Required Permits	42
8.3	Streamlining the Process	43
8.3.1	Heritage Permit	44
8.3.2	Heritage Permit with Building Permit	46
8.3.3	Heritage Permit with Site Plan Approval	47
8.3.4	Review of Zoning Amendment and Committee of Adjustment Applications	48
8.4	Resolving Issues and Appeals	49
8.5	Plan Renewal	49
8.5.1	Reviewing Bodies	49
8.5.2	Regular Review	50
8.5.3	Amendments	50
8.6	Enforcement	50
8.7	Public Awareness	50
8.8	Application Checklists	52

Part D Design Guidelines

9.0 Guidelines for Buildings and Surroundings

9.1	Architectural Styles	58
9.1.1	Heritage Styles Residential Buildings	58
9.1.2	Heritage Styles Commercial Buildings	74
9.1.3	Heritage Styles Agricultural	77
9.1.4	Non-Heritage Styles Residential Buildings	78
9.2	Heritage Design and Details	81
9.2.1	Introduction	81
9.2.2	Composition	81
9.2.3	Entrances and Doors	83
9.2.4	Windows and Shutters	85
9.2.5	Bay Windows	86
9.2.6	Gable Ends	87
9.2.7	Dormers	88
9.2.8	Porch Design	89

9.2	Heritage Design and Details Cont'd	
9.2.9	Brickwork	90
9.2.10	Wood Siding	92
9.2.11	Fencing	93
9.3	Existing Heritage Buildings	94
9.3.1	Overview	94
9.3.2	Historical and Technical Research	95
9.3.3	Recording Original Construction	95
9.3.4	Building Maintenance	96
9.3.5	Repair and Restoration	100
9.3.6	Renovations	104
9.3.7	New Additions to Heritage Buildings	105
9.3.8	Outbuildings for Heritage Buildings	107
9.4	Existing Non-Heritage Buildings	108
9.4.1	Design Approaches	108
9.5	New Development	110
9.5.1	Overview	110
9.5.2	Residential Area	111
9.5.3	Commercial Core	115
9.6	Streetscape Work	126
9.6.1	Overview	126
9.6.2	The Residential Streets	127
9.6.3	Commercial Core	128
9.7	Landscaping	132
9.7.1	Planting	132
9.7.2	Warning! Invasive Species	133
9.8	Building Materials Checklist	134
9.8.1	Heritage Buildings	134
9.8.2	Non-Heritage Buildings	136

10 .0 Sources

10.1 Documents Available for Guidance	<u>137</u>
10.2 Bibliography	<u>137</u>

Part E Appendices

Appendix A: A Glossary of Architectural Terms	<u>141</u>
---	------------

Part A

District
Overview





The Bailey Store, Maple. This shop was located on Keele Street, one lot North of Major Mackenzie Drive, where the north part of the Shoppers Drug Mart now stands. Undated photograph from the City of Vaughan Archives.

1.1 The Heritage Conservation District Concept

A heritage conservation district is a collection of buildings, streets, and open spaces that collectively are of special historical and/or architectural significance to the community. The individual elements of a district must combine in such a way as to present a sense of cohesiveness. A heritage district is a place of special character or association with an integrity of its own that distinguishes it from other areas of the community.

Part V of the *Ontario Heritage Act R.S.O. 1990, O.18* provides for the designation of heritage conservation districts. The parameters of this legislation enable municipalities, through study, to define the areas to be designated and to use development guidelines to assist in the regulation of various types of development within heritage conservation districts in order to ensure that the district's character and viability are maintained and/or enhanced.

It is not the purpose of heritage conservation district designation to make the district a static place where change is prohibited. Rather, the purpose is to guide change so that it contributes to the district's architectural and historic character.

1.0 Introduction

1.2 Background to the District Plan

The City of Vaughan is committed to preserving its past. Cultural Services recognizes its heritage properties in two ways. It maintains the City of Vaughan Heritage Inventory which identifies all properties that are of interest to Cultural Services Division. Within the City of Vaughan Heritage Inventory, properties that have been researched and evaluated are catalogued and described in the *Listing of Significant Heritage Structures*, the City of Vaughan's Register of Property of Cultural Heritage Value as per Part IV, Subsection 27 of the Ontario Heritage Act (approved by Council on June 27, 2005.)

Included in the *Listing of Significant Heritage Structures* are all individual properties designated under Part IV of the Ontario Heritage Act and those properties within the heritage conservation districts of Kleinburg-Nashville and Thornhill-Vaughan (which are designated under Part V of the Ontario Heritage Act) that are seen to have architectural or historical significance. Each district has a Heritage Conservation District Plan to guide development activity so that it preserves and enhances the heritage character within those districts.

Vaughan Council established its interest in the creation of a heritage conservation district in Maple with Official Plan Amendment (OPA) 350, which was adopted by Council on September 17, 1990 by By-law No. 303-90, and received final approval from the Minister of Culture in May of 1993. OPA 350 states, in Section 8.0 Heritage Conservation:

a) The Plan shall endeavour to ensure the retention and preservation of heritage resources in the Maple Community. Council will adopt whatever means available to preserve and incorporate heritage resources within future development proposals wherever possible.

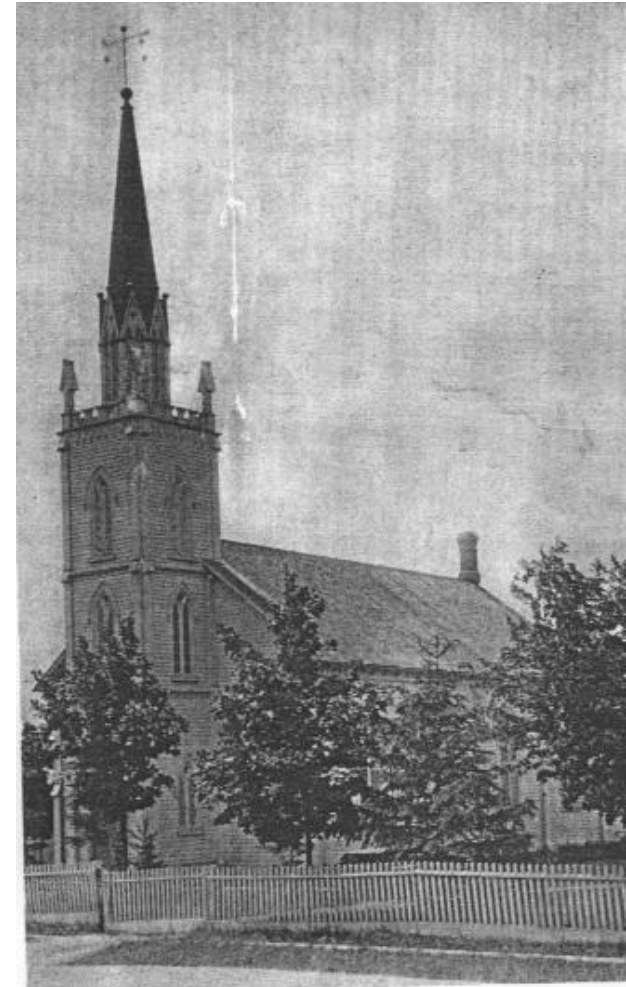

Saint Andrew's Presbyterian Church,
9860 Keele Street. Undated photograph
from the Vaughan Archives.

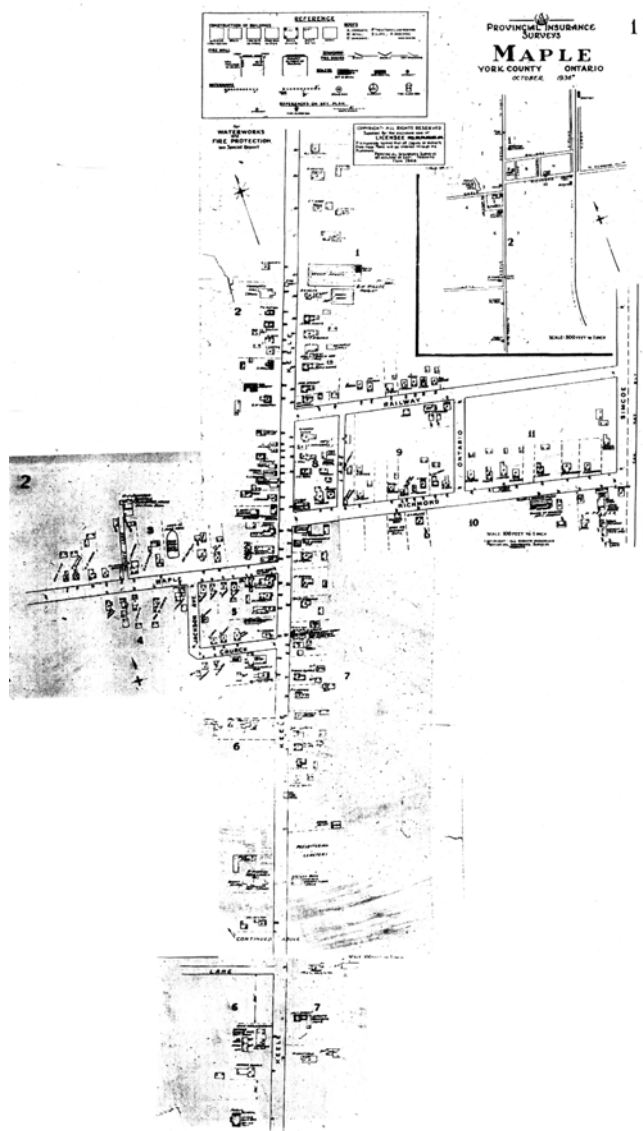

Map 1. Fire Insurance Map of Maple, 1936.
From the Vaughan Archives.

In Section 8.0 c) The Plan specifically enables the creation of Heritage Conservation Districts, and specifies the process for doing so:

c) In consultation with Heritage Vaughan, Council may, by by-law:

i) designate individual properties to be of historic or architectural value or interest pursuant to Part IV of the Ontario Heritage Act;

ii) define the municipality, or any area or areas within the municipality, as an area to be examined for designation as a heritage conservation district; and

iii) designate the municipality, or any area or areas within the municipality, as a heritage conservation district pursuant to Part V of the Ontario Heritage Act.

Prior to the designation of a Heritage Conservation District or Districts, Council will prepare and adopt a Heritage Conservation District Plan for the area or areas which will include policies respecting the protection and enhancement of the district and conservation and design guidelines for both existing buildings and new construction. The Heritage Conservation District Plan will be prepared in accordance with the guidelines established by the Ministry of Culture Tourism and Recreation. (Note: Now the Ministry of Culture.)

1.0 Introduction

Concern about the special character of Maple led Council, in 1996, to commission the Maple Streetscape and Urban Design Guidelines Study, by KMK SCI Consultants and the City of Vaughan Planning Department.

Staff subsequently recognized that the study, although useful, lacked the tools to protect and enhance the heritage aspects of the village. As a result, Council commissioned a Heritage Review of the Study, by Phillip H. Carter Architect and Planner in 2003. Both the Study and the Heritage Review are described in more detail below.

Wishing to make use of the enhanced development controls available under the Ontario Heritage Act, Council has since determined that a study should be undertaken for a Village of Maple Heritage Conservation District, and By-law 366-2004, designating a Study Area, was passed on December 6, 2004. Phillip H. Carter Architect and Planner was engaged to conduct the study and, if a Heritage Conservation District is found to be appropriate, to prepare the Village of Maple Heritage Conservation District Plan.

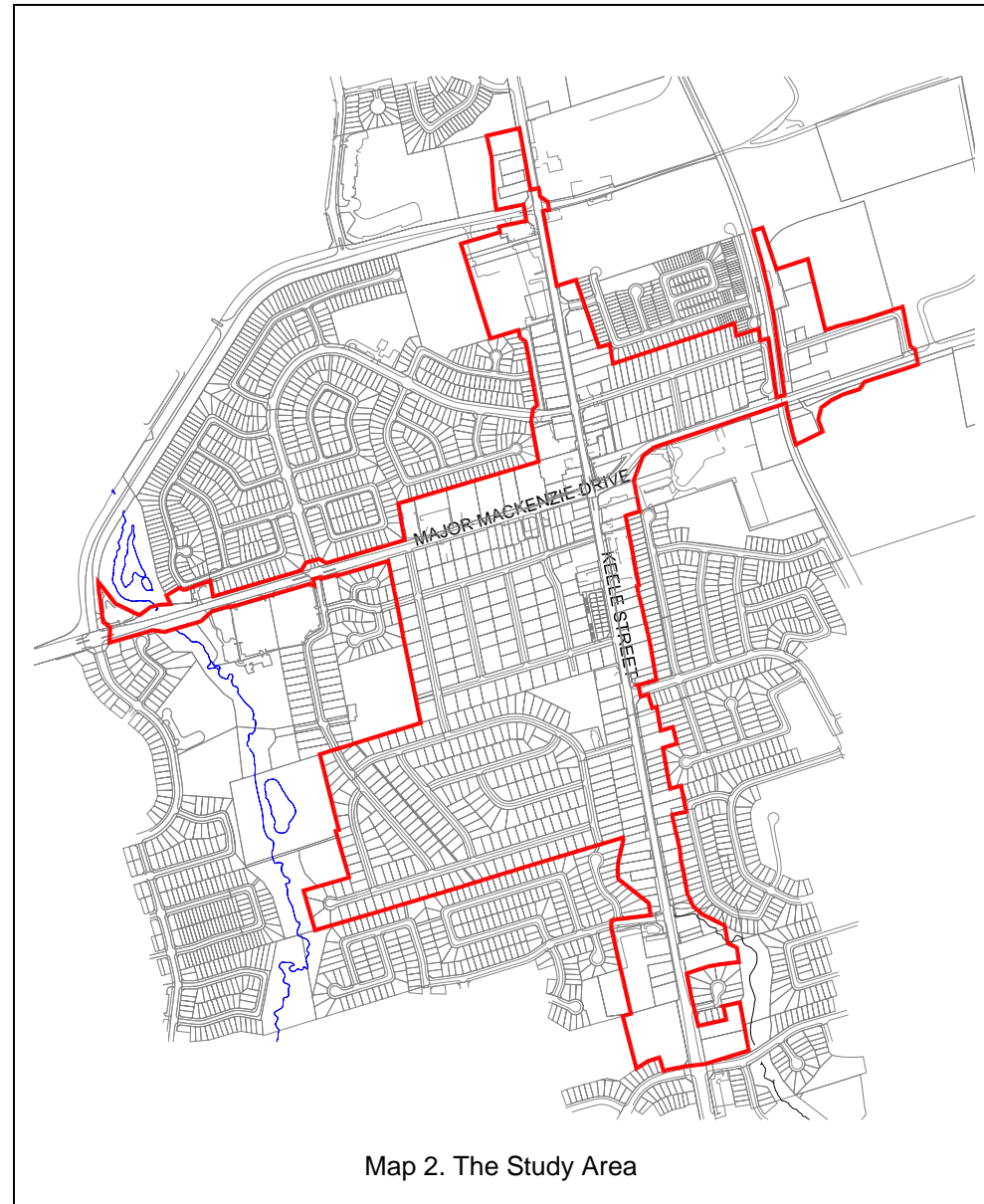

Map 2. The Study Area

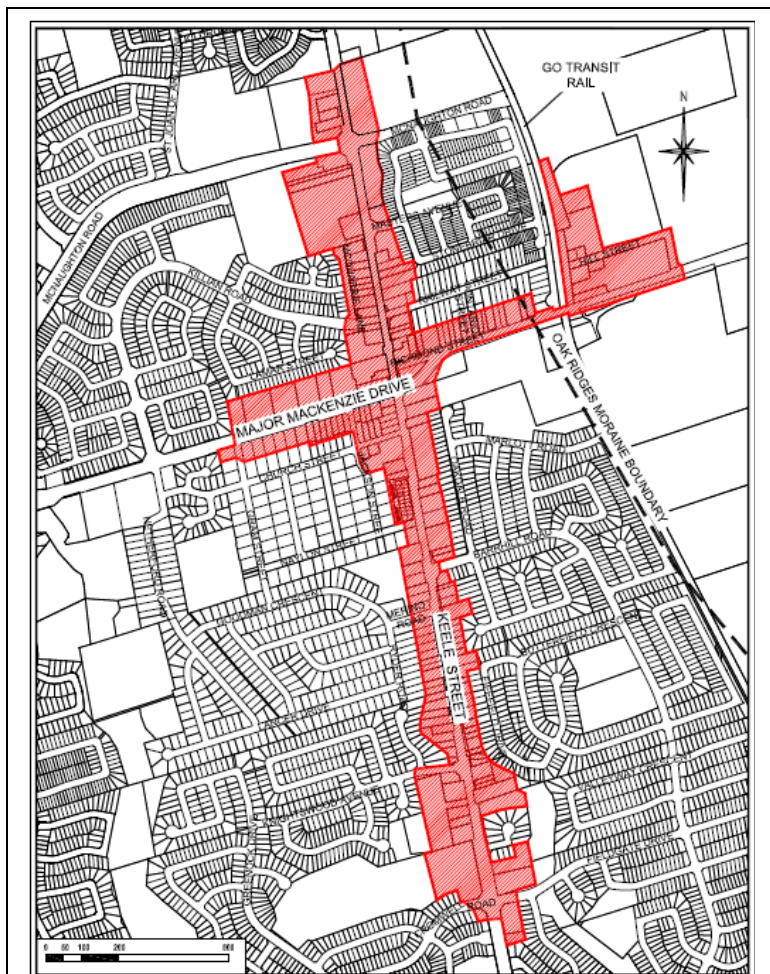

Map 3. The Boundary of the Village of Maple Heritage Conservation District. The District provides protection for the heritage resources in the old village, and controls the appearance of future development that will form their setting.

1.3 The District Documents

The Village of Maple Heritage Conservation District Plan is published in three volumes:

1. The Record of the District's Built Form.
 - Includes every property in the Study Area.
 - Contains photographs and descriptions of each building.
 - Contains historical information, where available.
2. The Study.
 - Describes the history of Maple.
 - Examines its physical and cultural heritage character.
 - Considers existing development controls.
 - Recommends that a Heritage Conservation District is warranted in The Village of Maple, and recommends a boundary for the District.
 - Contains a Statement of Heritage Value.
 - Contains a Statement of Heritage Interest.
3. The Plan

1.3.1 Unity of the Documents

These documents are complementary, and they are to be considered as a whole in interpreting the Plan.

1.4 The District Boundary

The Heritage District boundary, determined by the Study, is shown in the map to the left.

2.0 Heritage Character and Heritage Statements

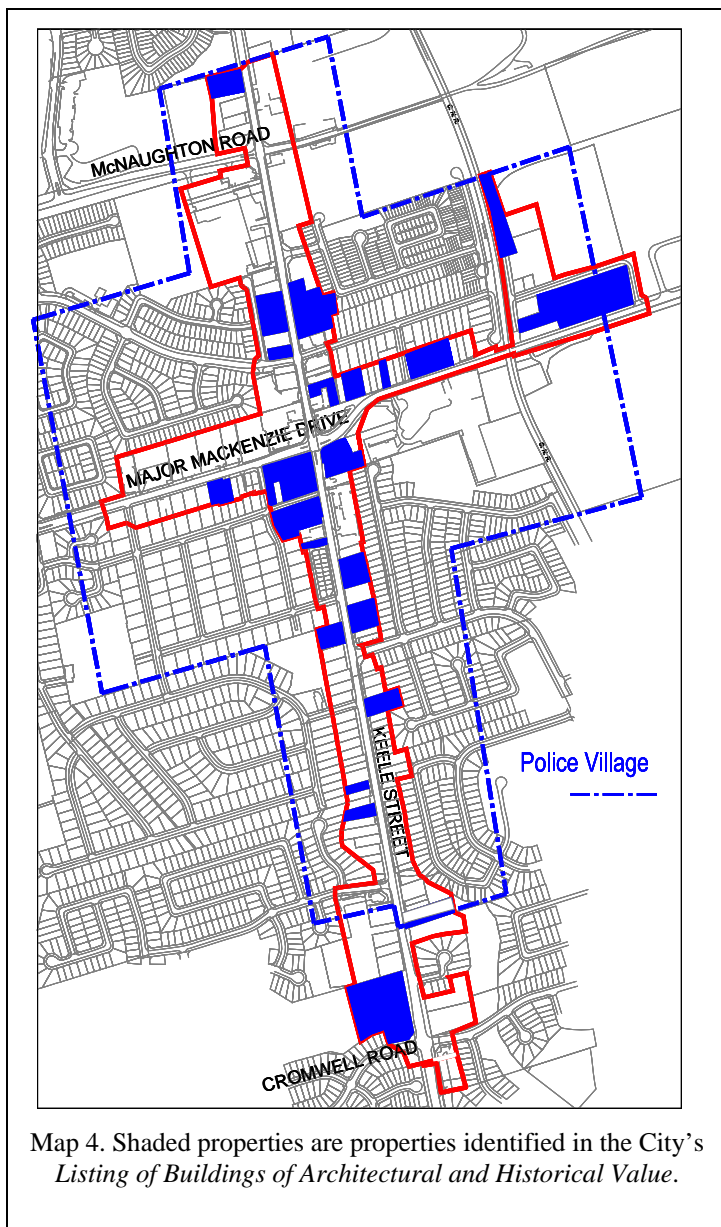

2.1 Heritage Resources

Within the District there are 51 properties that are identified in the *City of Vaughan Heritage Inventory*. These are all shown as shaded on the map to the left. They provide a general outline of the shape of the old village settlement, which was mostly located along the main roads of Keele Street and Major Mackenzie Drive. Some of these properties have been researched, examined, and evaluated, and have also been recognized in the *City of Vaughan Listing of Buildings of Architectural and Historical Value*.

The establishment of the Police Village of Maple in 1928 recognized the status of a small but significant settlement, much like what is shown in the 1936 map on page 5. The village didn't grow much in the next 20 years, and a 1955 map shows only a few more buildings added to the south and on Railway Street. The west side of Keele south of Church Street remained largely unbuilt. In the southwest quadrant, Church, Naylor, Jackson, Welton, Oldfield, and Gram Streets were laid out, but only the first blocks of Church and Jackson had houses on them. Even in 1955, most of the land within the Police Village was rural.

There are four properties in the Village of Maple Heritage Conservation District that are individually designated under Part IV of the Ontario Heritage Act:

- St. Andrew's Presbyterian Church, 9860 Keele Street,
- Beaverbrook House, 9995 Keele Street,
- Saint Stephen's Anglican Church, 10111 Keele Street,
- Maple Cemetery Vault, 2000 Major Mackenzie Drive.

In addition, the Maple railway station, at 30 Station Street, was designated federally in 1993, under the Heritage Railway Protections Act.

Note: Refer to the Record of the District's Built Form, published in a separate volume, for detailed descriptions of individual properties.

2.0 Heritage Character and Heritage Statements

2.2 Statement of Heritage Value

The Village of Maple is one of four 19th century settlements in the City of Vaughan that could have been considered more than a hamlet. (Two of these, Thornhill and Kleinburg-Nashville, have been made Heritage Conservation Districts.) The Ontario Huron and Simcoe Railway, the first railway in Canada, provided the opportunity for its modest prosperity. The core of the village was always small, with some outlying houses and businesses spaced out along the main roads on the outskirts. Today, Maple has many newer buildings, which have filled in the spaces between earlier ones, and in some cases replaced them. Nonetheless, there is a wealth of 19th and early 20th century buildings, and the character of a village remains evident. Newer development has tended to make design reference to heritage styles, with mixed success. To ensure that existing heritage resources are preserved, and that new development authentically enhances the village character, a Village of Maple Heritage Conservation District is proposed. The proposed District consists of the historic block of Church and Jackson Streets, and properties along the two main roads, roughly to the extent of the old Police Village.

The Village of Maple Heritage Conservation District is a distinct area in the City of Vaughan, characterized by a wealth of heritage buildings, and with many newer buildings that respect the scale and site plan characteristics of a historic village. The heritage character, shown in Sections 4.1 through 4.8 of this Study, is worthy of preservation.

2.3 Statement of Heritage Attributes

The overall heritage attributes are described in the examination in Section 4 of the Study. The heritage attributes of individual buildings are described in the Record of the District's Built Form. The Study and the Record are part of this Plan, but are published in separate volumes.

2.4 Statement of Objectives in Designating the District

2.4.1 Overall Objective

To ensure the retention and conservation of the District's cultural heritage resources and heritage character, and to guide change so that it contributes to, and does not detract from, the District's architectural, historical, and contextual character.

3.0 Heritage Character and Heritage Statements

2.4.2 Objectives for Heritage Buildings

To retain and conserve the heritage buildings identified in the District Plan on Map 4, found on page 8.

To conserve heritage attributes, distinguishing qualities or character of heritage buildings and avoid the removal or alteration of any historic or distinctive architectural feature.

To correct unsympathetic alterations to heritage buildings.

To undertake the restoration of heritage buildings based on a thorough examination of archival and pictorial evidence, physical evidence, and an understanding of the history of the local community.

2.4.3 Objectives for Non-Heritage Buildings

To retain and enhance complementary characteristics of non-heritage buildings.

To encourage improvements to non-complementary buildings so that they further enhance the heritage character of the District.

2.4.4 Objectives for Landscape/Streetscape

To facilitate the introduction of, as well as conservation of, historic landscape treatments in both the public and private realm.

To preserve trees and mature vegetation, and encourage the planting of species characteristic of the District, where possible. Native urban-tolerant trees are preferred; however, non-indigenous species with compatible forms and characteristics should be allowed in recognition of the harsher urban conditions that now exist.

To introduce landscape, streetscape, and infrastructure improvements that will enhance the heritage character of the District.

2.4.5 Objectives for New Development

To ensure compatible infill construction that will enhance the District's heritage character and complement the area's village-like, human scale of development, while promoting densities sufficient to secure the District's future economic viability.

To guide the design of new development to be sympathetic and compatible with the heritage resources and character of the District while providing for contemporary needs.

2.4.6 Objectives for Community Support

To foster community support, pride and appreciation of the heritage buildings, landscapes, and character of the District, and promote the need to conserve these resources for future generations.

To facilitate public participation and involvement in the conservation of heritage resources and further development of the District.

To offer assistance and incentives to individual heritage property owners to encourage the use of proper conservation approaches when undertaking improvement projects.

2.4.7 Business/Tourism

To work with owners in the Commercial Core to maintain a progressive and competitive business environment while at the same time protecting the heritage attributes of the District that make the area a unique and distinctive shopping environment.

To acknowledge that the Heritage District is an asset that contributes to the commercial success of the District and the larger municipality.

3.0 Review and Interpretation

3.1 Review of Activities in the District

3.1.1 Activities subject to review

In accordance with Section 42.1 of the *Ontario Heritage Act*, the Goal and Objectives, Policies, and Design Guidelines in this document will be used to review the following types of activities in the District (other than those exempted below). In particular, as it relates to the review and approval of a Heritage Permit application:

- The erection, demolition, or removal of any building or structure, or the alteration of any part of a property other than the interior of a building or structure, other than activities described in Section 3.1.2, below. (A 'Structure' is anything built that is intended to be permanent, such as outbuildings, fences, signs, and infrastructure items such as utility boxes.)
- All matters relating to the City of Vaughan Official Plan, and the regulation of zoning, site plan control, severances, variances, signage, demolitions, and building relocation.
- All municipal public works, such as street lighting, signs, landscaping, tree removal, utility locations, and street and infrastructure improvements.
- All activities of the municipal and regional governments.

3.1.2 Activities exempt from review

In accordance with Section 41.1 (5)(e) of the *Ontario Heritage Act*, the following classes of alterations that are minor in nature, are not required to obtain a heritage permit, and are not subject to review under this Plan:

- any interior work;
- repair to roof, eavestroughs, chimneys; re-roofing using appropriate material listed in Section 9.8;

- caulking, window repair, weatherstripping, installation of storm doors and windows;
- minor installations, including small satellite dishes, lighting, and flagpoles;
- fencing, patios, garden and tool sheds, gazebos, dog houses and other outbuildings that do not require a Building Permit and are not readily visible from the street;
- planting, and removal of trees smaller than 200mm caliper, measured at 1.5m above the ground, and any other vegetation on private property;
- Extension of residential parking pads other than in front or flankage yards;
- Ramps and railings to facilitate accessibility, gates installed for child safety that are located in such a manner as to not be visible from the public domain;
- Temporary installations, such as basketball nets, planters, statues, seasonal decorations; and
- Repair of utilities and public works, installation of public works that are in compliance with the Guidelines.

3.2 Contexts for Interpretation

Provisions of the District plan should be considered within the contexts of:

- The Provincial Policy Statement, and
- Overall municipal objectives and goals.

In accordance with Section 41.2 of the *Ontario Heritage Act*, Council may not pass a by-law for any purpose that is contrary to the objectives set out in the Heritage Conservation District Plan. In the event of a conflict between the Plan and a municipal bylaw that affects the District, the Plan prevails to the extent of the conflict.

Part B

District Policies

4.0 District Policies—Buildings and Sites

4.1 Overview

The Maple Village Heritage Conservation District has a wealth of heritage resources, and a recognizable heritage character. The heritage character of the District is enhanced by streetscapes, planting, fencing, open spaces, vistas, and natural areas.

The Plan and its Policies anticipate change. Heritage buildings will be restored, reused, and have additions. Non-heritage buildings will also be added to or altered. New buildings will be constructed. The purpose of the Plan is to ensure that these activities are complementary to both the individual heritage buildings and the overall heritage environment in the District.

To preserve and enhance the heritage character of the District, policies have been developed concerning the following.

- heritage buildings;
- non-heritage buildings;
- new buildings; and
- landscapes.

The Policies are supported by illustrative guidelines, which are found in Section 9.0 of the District Plan.

4.0 District Policies—Buildings and Sites

4.2 Heritage Buildings

Maple is well known for its attractive collection of nineteenth and early twentieth century village buildings of varied types and styles. The District consists of a predominantly residential building stock, but there are also two churches, outbuildings/barns, and commercial buildings. Although some of the buildings are not in their original uses, the distinctiveness of their form and compatibility of their adaptations serve to perpetuate the historical village environment. The retention of these buildings is essential to the success of the District. Therefore, the intent is to conserve and restore these resources, prevent their demolition and if necessary, ensure their relocation or salvage.

For the purposes of this Plan, any property identified on Map 4, found on page 8, is considered a heritage property. This includes buildings in the City of Vaughan Heritage inventory, and four additional properties identified by the consultants. Those that are also in the *Listing of Significant Heritage Structures* have been evaluated. Other buildings have been identified, but not yet evaluated. These buildings will require evaluation if significant work, relocation, or demolition is proposed.

The conservation of heritage buildings involves actions or processes that are aimed at safeguarding the heritage attributes of the resource so as to retain its heritage value and extend its physical life. Conservation can involve preservation, rehabilitation, restoration or a combination of these actions. These terms are defined as follows:

- **Preservation:** The action or process of protecting, maintaining, and/or stabilizing the heritage attributes (materials, form, integrity) of the entire heritage resource (or an individual component of the resource) while protecting its heritage value.

4.0 District Policies—Buildings and Sites

- **Rehabilitation:** The action or process of ensuring a continuing use or a compatible contemporary use of a heritage resource (or an individual component) through repair, alterations, or additions, while protecting its heritage value. This can include replacing missing historic features either as an accurate replica of the feature or may be a new design that is compatible with the style, era, and character of the heritage resource.
- **Restoration:** The action or process of accurately revealing, recovering, or representing the state of the heritage resource (or of an individual component), as it appeared at a particular period in its history, while protecting its heritage value. This could include removal of features from other periods in its history and the reconstruction of missing features from the restoration period (based on clear evidence and detailed knowledge).

4.2.1 Conservation of Heritage Buildings

- a) Conserve and protect the heritage value of each heritage resource. Do not remove, replace, or substantially alter its intact or repairable heritage attributes.
- b) Conserve changes to a heritage resource which, over time, have become heritage attributes in their own right.
- c) Conserve heritage value by adopting an approach involving minimal intervention.
- d) Evaluate the existing condition of heritage attributes to determine the appropriate intervention needed. Use the gentlest means possible for any intervention.
- e) Maintain heritage attributes on an ongoing basis to avoid major conservation projects and high costs.

4.0 District Policies—Buildings and Sites

- f) Repair rather than replace heritage attributes using recognized conservation methods. Respect historical materials and finishes by repairing with like materials.
- g) Replace using like material any extensively deteriorated or missing parts of heritage attributes.
- h) Correct inappropriate interventions to heritage attributes.
- i) Undertake any work required to preserve heritage attributes physically and visually compatible with the heritage resource.
- j) Respect documentary evidence. Conservation work should be based on a thorough examination of physical and archival evidence. Where there is insufficient evidence, it may be appropriate to make the design, form, material, and detailing of the new feature or element compatible with the character of the heritage resource as commonly found in the District.

4.2.2 Alterations and Additions to Heritage Buildings

- a) Conserve the heritage value and heritage attributes of a heritage resource when creating any new addition or any related new construction. Make the new work physically and visually compatible with, subordinate to, and distinguishable from the heritage resource.
- b) Ensure that any new addition, alteration, or related new construction will not detrimentally impact the heritage resource if the new work is removed in future.
- c) Alterations and additions to the heritage resource shall conform with the Guidelines found in Section 9.3.

4.2.3 Relocation of Heritage Buildings

- a) Relocation or dismantling of a heritage building will be employed only as a last resort.
- b) Buildings of cultural heritage value shall be retained in situ (at their original locations) whenever possible. Before such a building can be approved for relocation to any other site, all options for on-site retention will be investigated. The following alternatives, in order of priority, will be examined prior to any approval of relocation for a heritage building:
 - Retention of the building on site in its original use;
 - Retention of the building on site in an adaptive re-use;
 - Relocation of the building to another part of the original site;
 - Relocation of the building to another site in the District; and
 - Relocation of the building to a sympathetic site within the City of Vaughan.
- c) A threatened heritage building relocated to the District from another site should generally be compatible in style and type to the existing development patterns in the District.

4.2.4 Demolition of Heritage Buildings

- a) The demolition of heritage buildings within a Heritage Conservation District is not supported.
- b) The City, under the *Ontario Heritage Act*, may refuse a demolition permit for either an individually designated building or a building located within the District.

4.0 District Policies—Buildings and Sites

4.2.5 Salvage of Historic Building Materials and Features

- a) In the rare case where a heritage building is permitted to be demolished, the building will be documented (researched and photographed) and the proponents of the demolition will be required to advertise in the local press, the availability of the building for relocation or salvage of architectural features, as a condition of the demolition permit.
- b) The City may require the demolition of a building to be undertaken in such a manner as to expose the construction techniques used for documentation and educational purposes.

4.2.6 Use of a Heritage Building

- a) The uses permitted for a heritage building will be governed by the zoning by-law.
- b) Uses that require minimal or no changes to heritage attributes are supported.

4.3 Non-Heritage Buildings

4.3.1 Additions and Alterations

The majority of the properties in the Village of Maple Heritage Conservation District are non-heritage buildings. Some of these properties are good neighbours to the heritage buildings in scale, massing, and design. There are also newer buildings that have been consciously designed to complement the heritage buildings in the village, some of these have been successful.

4.3.2 Design Approach

Alterations and additions to non-heritage buildings in the District should be consistent with one of two design approaches: Historical Complementary or Modern Complementary as described in the Guidelines in Section 9.4.

4.3.3 Demolition of Non-Heritage Buildings

Generally, the demolition of a Non-Heritage building is not supported, if the building is supportive of the overall heritage character of the District.

4.0 District Policies—Buildings and Sites

4.4 New Residential Buildings

New residential buildings will have respect for and be compatible with the heritage character of the District. Designs for new residential buildings will be based on the patterns and proportions of the 19th century and early 20th century building stock that are currently existing or once existed in the village. Architectural elements, features, and decorations should be in sympathy with those found on heritage buildings.

4.4.1 Design Approach

- a) The design of new buildings will be products of their own time, but should reflect one of the historic architectural styles traditionally found in the District.
- b) New residential buildings will complement the immediate physical context and streetscape by: being generally the same height, width, and orientation of adjacent buildings; being of similar setback; being of like materials and colours; and using similarly proportioned windows, doors, and roof shapes.
- c) New residential building construction will respect natural landforms, drainage, and existing mature vegetation.
- d) Larger new residential buildings will have varied massing, to reflect the varied scale of built environment of the historical village.
- e) Historically appropriate façade heights for residential buildings has been 1 - 1/2 or 2 storeys. The façade height of new residential buildings should be consistent with the façade height of existing buildings. Differences in façade heights between buildings on adjacent properties within the district should be no more than 1 storey. In all instances the height of new buildings shall conform to the provisions of the City's Zoning By-law.

New residential building construction in the District will conform with the Guidelines found in Section 9.5.2.

4.0 District Policies—Buildings and Sites

4.5 Landscapes

Landscapes and Landscaping helps to define the character of the District, and to provide an appropriate setting for its historic buildings. The Ontario Heritage Act extends alteration controls to cover property features, in addition to the exterior of buildings and structures. Property features can include trees, vegetation, pathways, fences, and other landscape elements that are of cultural heritage value or interest.

4.5.1 Landscape Treatment

Existing historical landscapes will be conserved. The introduction of complementary landscapes to the heritage environment will be encouraged. Landscape Guidelines are provided in Section 9.7.

4.5.2 Trees and Shrubs

- a) Mature trees will be preserved except where removal is necessary due to disease or damage, or to ensure public health and safety, as certified by a professional arborist. Lost trees should be replaced.
- b) New trees and shrubs should be hardy, urban tolerant in recognition of harsher environmental conditions, but that express form, canopy, leaf and colour characteristics of native, indigenous trees, where possible. Large, urban-tolerant and long-living character trees are to form the framework of street tree plantings in the area and become a defining characteristic of the area. Where sufficient space does not exist for large trees, smaller ornamentals are preferred to induce a pedestrian scale while providing seasonal interest and colour.
- c) Planting should not obscure heritage buildings, but can frame important features. Planting should screen less attractive sites and prospects in the District.

4.5.3 Fences

- a) Fences will be regulated by the municipal fence by-law.
- b) Existing historical fences will be preserved. The erection of new fences of historic designs is encouraged. See Section 9.2.11 for guidelines.

4.0 District Policies—Buildings and Sites

4.6 Commercial Core

In order to help retain and enhance the heritage character of the District, specific guidance is needed to address both new and existing commercial buildings on Keele Street, Richmond Street, and Major Mackenzie Drive. The commercial features having an impact on the exterior of buildings such as signage, awnings, restaurant patios, and parking lots should also be addressed. For the purposes of this Plan, all commercial sites within the district, regardless of Official Plan designation, shall be developed in accordance with the policies and guidelines of this Plan.

4.6.1 Design Approach

- a) The design of new buildings will be products of their own time, but should reflect an historic architectural style either traditionally found in the District or reflective of traditional commercial architecture.
- b) A design approach that reduces the actual and perceived scale of large developments will be pursued.
- c) New buildings will respect adjacent residential and historic properties.
- d) The façade of new buildings will be no taller than 3 storeys, with a maximum height of 11.8 metres.
- e) New building construction in the District will conform with the Guidelines found in Section 9.5.3.

4.0 District Policies—Buildings and Sites

4.6.2 Commercial Signage

- a) Commercial signage will be regulated by the City of Vaughan By-law 203-92.
- b) The Maple Special Sign District should include the Heritage District boundary.
- c) Commercial signage in the District will be consistent with the Guidelines found in Section 9.5.3.9.
- d) Artistic and commercial murals are not permitted.

4.6.3 Commercial Awnings

Awnings on commercial buildings will be consistent with the Guidelines found in Section 9.5.3.8.

4.6.4 Commercial Patios

- a) Restaurant or commercial patios will be regulated by the municipal Zoning By-law.
- b) Restaurant or commercial patios will be consistent with the guidelines found in Section 9.5.3.

4.6.5 Commercial Parking Lots

- a) Attractive, well-designed parking lots that complement the special character of the District are supported. Parking will not be permitted to be located in front of buildings.
- b) Parking lots will be appropriately landscaped and screened. Features such as lighting, signage, and amenities used in parking lots will be consistent in design terms with the Maple Streetscape Guidelines and the guidelines contained within Section 9 of this Plan.
- c) The integration and connection of individual commercial parking lots is supported, due to the collaborative nature and interdependence of the various commercial enterprises in the Commercial Core, and in order to improve the efficiency and limit the number of driveways gaining access from Keele street and Major Mackenzie Drive.
- d) The development of underground parking facilities, appropriately located and sited, is supported.

5.0 District Policies—Streetscape and Infrastructure

5.1 Overview

The following policies address those components of the District located primarily in the public realm. These features include roads, curbs, municipal services, parking facilities, sidewalks, boulevards, street furniture, pedestrian amenities, lighting, utilities, public signage, vegetation, parkettes, and open space. The proper treatment of these features can enhance the heritage character of the District.

5.2 Roads, Curbs, and Municipal Services

The provision of adequate roads, curbs, storm and sanitary sewers, and water supply are essential components for a living Heritage District.

Policies:

- a) Road, curb, and servicing improvements will be undertaken in a manner that preserves and enhances the heritage character of the District.
- b) Existing pavement widths should not be increased.
- c) Provision of on-street parking in off-peak hours, which increases the sense of pedestrian safety, is supported.
- d) In general, all aspects of road design that improve pedestrian amenity are supported.
- e) The vision of Vaughan as a walking community and policies of the Pedestrian and Bike Plan are supported by this Plan.

5.0 District Policies—Streetscape and Infrastructure

5.3 Sidewalks and Boulevards

The existing sidewalk and boulevard treatment in the District, varies from block to block. Church Street retains a curbless rural profile. In some areas there are grassed boulevards outside of the sidewalk. In other areas the sidewalk is at the curb. The retention and extension of planted boulevards, to the extent it is possible, can help preserve and enhance an informal, village-like atmosphere.

Policies:

- a) The absence of sidewalks on Church Street is supported, as it contributes to the village character.
- b) The alignment of the sidewalk on the east side of Keele Street, south of Barrhill Road, which is set inside of the street trees, and curves around them, is supported, as it contributes to an informal village character. Where possible, similar sidewalk alignments are supported.
- c) Sidewalks should be constructed of concrete rather than modern materials that often take on an overly tailored appearance.
- d) Where possible, grassed boulevards and planting near the roadway is encouraged.

5.0 District Policies—Streetscape and Infrastructure

5.4 Street Furniture and Pedestrian Amenities

Street furniture and related pedestrian amenities should be part of a co-ordinated design approach, to help define the District as a distinctive and special area.

Policies:

- a) Street furniture and related pedestrian amenities such as benches, trash and recycling receptacles, bicycle racks, telephone booths, and newspaper box enclosures will be provided as required, will be consistent through the District, and will conform to the Guidelines in Section 9.6.
- b) Street and other outdoor lighting will be appropriate in light intensity to the function of the street.

5.5 Street Lights and Utilities

Street lights and utility wires are necessary in all communities. A distinct street light and absence of overhead wires can be a cohesive element that ties the District together and defines it as a special area. The inappropriate location of items such as transformers, metres and switching stations has a negative impact on the heritage landscape of a community.

Policies:

- a) Over time, a consistent street light will be used throughout the District to enhance its identity as a heritage area. The selected street light fixture will reflect the village-like, heritage character of the District.
- b) Street and other outdoor lighting will be appropriate in light intensity to the function of the street.
- c) Any lighting fixtures introduced in parking lots (public or commercial) will reflect the heritage character of the District and be consistent with the design chosen to be used throughout the District.
- d) Utilities such as metres, switching stations and transformers should be located in a manner that they are not readily visible from the street and do not unduly impact the heritage landscape of the District.

5.0 District Policies—Streetscape and Infrastructure

5.6 Public Signage

Typical public signage includes directional, regulatory, identity, and public information signs. If properly developed, these signs can promote a coordinated identity supportive of the heritage area.

- a) Regulatory signs should be the same type of sign used elsewhere in the municipality.
- b) A design for Heritage District identification signs should be developed to help promote awareness of the District. The design should have a simple, distinctive shape, and should be mounted with street name signage in the District.
- c) Heritage District entry signs should be designed and installed at the four gateway points. The design, colour, and materials of street name signs, entry signs, and other public information signage will be consistent and complementary to the District character.
- d) A distinctive sidewalk stamp for the District should be developed, to be embossed at intersections when new sidewalk sections are installed.
- e) A village notice board, including a map identifying the heritage conservation district, should be erected as part of the streetscape design near Beaverbrook House.

5.0 District Policies—Streetscape and Infrastructure

5.7 Vegetation

The vegetative cover in the public realm of the District significantly contributes to the area's human-scale, village-like character. Street trees, flowers in baskets, shrubs, and vegetation found in the open spaces and along watercourses all contribute to the area's distinctiveness. In addition to their scenic beauty, trees and other vegetation are equally important for controlling the effects of climate by reducing wind velocity, providing shelter from sun, rain, and snow, and creating a moderated microclimate.

- a) Plant material introduced to the public realm should be hardy, urban tolerant in recognition of harsher environmental conditions, but that express form, canopy, leaf and colour characteristics compatible with native, indigenous trees, where possible.
- b) Existing mature trees and other vegetative amenities in the public realm should be retained and preserved except where removal is necessary due to disease or damage, or to ensure public health and safety.
- c) The shaping of street tree canopies for utility wires will be undertaken in a sensitive manner so as not to disfigure the tree. The impact of this process on existing trees may be a factor when burial of utility wires is being considered.
- d) An appraisal of the health of tree cover in the public realm will be undertaken with the result being a replanting policy or plan to replace unhealthy trees and coordinate new plantings.
- e) The placement of new tree-plantings should enhance the streetscape and frame buildings of cultural and heritage value and minimize the screening or blocking of significant features.
- f) Plantings will contribute to screening less attractive sites in the District, including above-ground utilities, where practical from an operation and maintenance perspective.
- g) Guidelines for appropriate vegetation are located in Section 9.7.

6.0 District Policies—Special Areas and Projects

6.1 Public Awareness

It is extremely important to ensure that all property owners and residents in a heritage conservation district are aware of, and have a clear understanding of, the policies, processes, and procedures which apply in the District. Education opportunities and a comprehensive communication strategy are essential.

6.1.1 Communications

Effective communication of District goals, policies and guidelines is important to the success of any Heritage Conservation District.

Policies:

- a) Information concerning the District and the District Plan, as well as related matters, will be made available to property owners, residents, and commercial tenants.
- b) The Heritage Conservation District by-law will be registered on title to every property in the district, in accordance with the *Ontario Heritage Act*.
- c) The heritage section of the City's website will ensure easy access to a Village of Maple Heritage Conservation District section which will include information such as:
 - i. historical information on the District;
 - ii. a map of the District;
 - iii. the Heritage Conservation District Plan, in the form of downloadable sections as PDF files;
 - iv. links to external websites with helpful heritage information, such as those listed in Section 10 this Plan.
- d) Additional opportunities and mechanisms to inform new homeowners and commercial tenants about the Heritage District and associated requirements through existing City department and operational requirements will be pursued.
- e) The City of Vaughan Property Information System should be altered to reflect the presence of a heritage restriction registered on title.

6.0 District Policies—Special Areas and Projects

6.1.2 Education

Education is a useful tool in preserving heritage resources, for owners of heritage properties, whether or not they are in the District, and for City Staff and members of Heritage Vaughan. Some recommended steps that might be undertaken include:

- a) The creation and promotion of learning opportunities for property owners in the District may be pursued. This may include special workshops or presentations, as well as the provision of written materials.
- b) The promotion of periodic learning opportunities for members of Heritage Vaughan to ensure a comprehensive understanding of the heritage conservation principles and policies as well as the specific policies of the Village of Maple Heritage Conservation District Plan is supported.
- c) A user-friendly information handout might be prepared to explain the heritage conservation easement concept and the associated agreement.

7.1 Overview

Municipal planning and development policies may have a greater impact on the heritage character of a District than do explicit heritage policies. It is important to integrate all policies that have a heritage impact in order to maximize the protection of the special character of the District.

7.2 Recognizing the Heritage District Plan

The purpose of the City of Vaughan Official Plan is to set out policies and programs to govern the nature, extent, pattern, and scheduling of development and redevelopment and other matters within a framework of general goals and objectives. One of the overall general goals of the Official Plan is to foster an understanding of and to endeavour to protect the heritage of the City.

Section 8 of Official Plan Amendment 350 specifically addresses the City's heritage conservation policies for the Village of Maple.

Policy:

- a) The Official Plan should be amended to recognize the Village of Maple Heritage Conservation District Plan 2006.

7.3 Land Use in the District

The general use of land in the District is identified in the Official Plan and its amendments, and is further refined in specific zoning by-laws for the area. Prominent land uses in the District include residential, commercial, institutional and open space, and a deviation from these uses is not recommended. However, some of the existing development standards associated with zoning by-laws do not reflect the traditional built form and streetscape character found in the District.

If not altered, this will result in applicants having to make application to the Committee of Adjustment for variances in order to implement the design guidelines presented in the District Plan.

Policy:

- a) Existing District land uses, designated in the Official Plan and the amendments and the prevailing zoning classifications are supported.
- b) Zoning By-law 1-88, as amended, will be reviewed to examine whether it is desirable to develop a zoning overlay for all or part of the District to reflect the existing built form.

7.4 Land Severance and Minor Variances

In addition to the matters to be addressed under the Planning Act, the Committee of Adjustment, in determining whether a consent is to be granted, consults with appropriate City departments and agencies and has regard for adjacent use (i.e., compatibility of the size, shape, and proposed use of the new lot with the adjacent uses), access considerations, and availability of services. Infilling in an existing urban area which economizes the use of urban space without disturbing the pattern of existing development, or perpetuating an undesirable pattern of development or prejudicing the pattern of future development is generally considered acceptable.

However, in commenting to the Committee of Adjustment on applications for severance or minor variance in the District, the City should only support such applications if the proposal is compatible with the objectives and policies of the District Plan.

- a) Each land division proposal and variance will be evaluated on its own merits and as to its compatibility with the objectives and policies of the Heritage Conservation District Plan.

7.0 Municipal Policies

7.5 Site Plan Control

All of the land within the boundaries of the City of Vaughan has been designated as a Site Plan Control Area under By-law 228-2005. This designation allows Council to approve plans and drawings as provided for in section 41 of the Planning Act, R.S.O., 1990.

Policy:

- a) Site plan control will apply to all properties in the District.
- b) The City should ensure that substantial projects in the District are reviewed, in the Site Plan Control process, by design professionals with an understanding of heritage work in collaboration with Heritage Vaughan. It may be desirable to obtain outside professional advice to supplement the expertise of City staff.

7.6 Signage By-law

The City of Vaughan By-Law 203-92 regulates signage in the City. Section 11 of the By-law establishes 'Special Sign Districts' in Thornhill, Kleinburg, Woodbridge, and Maple.

Policy:

- a. The Maple Special Sign District should be revised to include the entire Heritage Conservation District.
- b. The Sign By-law should be amended to strengthen its protection of the heritage character in the Heritage District. In particular, internally illuminated signs and awning signs should be prohibited, and awnings should be required to be retractable, have a traditional profile and be of a traditional material.
- c. The Sign By-law should be enforced.

7.0 Municipal Policies

7.7 Demolition Control

Recent amendments to the Ontario Heritage Act allow Council to prohibit the demolition of a structure designated under the Act. Properties within a heritage conservation district are considered to be designated.

Policy:

- a) Council will prevent the demolition of heritage buildings within the District.

7.8 Heritage Easements

A Heritage Easement agreement requires the owner of a heritage building to secure approvals for any changes or alterations, reasonably maintain the structure to prevent any deterioration, and retain insurance on the building in an amount equal to its replacement.

Policy:

- a) A Heritage Easement Agreement should be considered for major redevelopment projects in the District which involve the incorporation and restoration of a heritage building.

7.9 Tax Measures

Recent provincial legislation allows municipalities to enact property tax abatement for properties designated under Part IV and Part V of the *Heritage Act*. The City should evaluate this legislation to determine if it can be usefully applied to the District.

7.10 Grants and Loans

The City of Vaughan should re-examine its Designated Property Subsidy Grant Program and a Community Heritage Loan Program.

Currently, the grant and loan programs are less active than they were in the past. For example, the 6% interest rate charged in the loan program was attractive when it was enacted, but in the current environment it is no better than an ordinary bank loan.

It would be worthwhile looking at programs in other municipalities. For example, the City of Barrie has a facade improvement loan program, pursuant to Section 28(7) & (8) of the *Planning Act*. Loans of up to \$20,000, covering up to half of an approved improvement, are forgivable at the rate of \$1,000/year. The administration of the program is designed to be straightforward, and user-friendly for both the applicant and the municipality.

The loss of heritage properties due to simple neglect is an avoidable tragedy and small levels of assistance have proven to be very effective in encouraging needed repairs and restoration. When a program designed to encourage conservation stops attracting applicants, it is time to redesign the program.

7.0 Municipal Policies

7.11 Preservation and Protection of Trees

The preservation and protection of mature vegetation is a major objective of the District Plan.

Policy:

- a) Prior to the issuance of a Heritage Permit, Building Permit or Site Plan approval a tree preservation plan is required to be submitted and approved by the City.

7.12 Community Improvement Area

According to the Official Plan, one of the actions that the City may undertake to improve the community's visual appearance is to periodically review heritage conservation districts and other areas to ascertain what improvements may be made to enhance their appearance and implement such improvements as feasible.

Part C

Implementing The District

8.1 Overview

Once Council has adopted the boundary and the Plan for the Heritage District and any appeals have been heard by the Ontario Municipal Board, a variety of measures is necessary to ensure the successful implementation of the District. These include:

- a) an application review process that is simple, efficient, and fair;
- b) a review body to provide advice on proposed alterations, new construction, demolitions in the District;
- c) the availability of the policies and guidelines for use by the public;
- d) the availability of financial assistance to assist in conservation initiatives;
- e) public awareness of the District concept, its objects, and its boundaries; and
- f) a mechanism to review and, if necessary, amend the District's policies and procedures.

8.2 Required Permits

The designation of a Heritage Conservation District invokes Section 42 of the *Ontario Heritage Act*, which states:

“Erection, demolition, etc.

42. (1) No owner of a property situated in a heritage conservation district that has been designated by a municipality under this Part (Part V) shall do any of the following, unless the owner obtains a permit from the municipality to do so:

1. Alter, or permit the alteration of, any part of the property, other than the interior of any structure or building on the property.
2. Erect, demolish, or remove any building or structure on the property or permit the erection, demolition or removal of such a building or structure.

Exception

(2) Despite subsection (1), the owner of a property situated in a designated heritage conservation district may, without obtaining a permit from the municipality, carry out such minor alterations or classes of alterations as are described in the heritage conservation district plan in accordance with clause 41.1 (5) (e) to any part of the property in respect of which a permit would otherwise be required under subsection (1).”

The classes of minor work exempted from the permit requirement are formally stated in Section 3.1.2 of this document. They are repeated, for convenient reference in Section 8.3.1.1, below.

8.0 Implementation

8.3 Streamlining the Process

In order to streamline and simplify procedures for permit applications and their review, the permit requirements for work in the district have been divided into classes, corresponding to the scale of the work being proposed, and have been integrated into the permit process for building and development. The permit classes are:

Important! Owners are encouraged to discuss their proposal work with Cultural Services Staff at the earliest stages to determine what will be required. Minor work that is exempted from the requirement for a Heritage Permit in Section 3.1.2 of this Plan, requires a Heritage Permit Clearance Letter from Cultural Services, to verify that the proposed work is exempted. See section 8.3.1.1. below.

The classes of Heritage Permit are:

- Heritage Permit, for minor work that does not require a building permit;
- Heritage Permit with Building Permit, for work that requires a building permit;
- Heritage Permit with Site Plan Approval, for work that requires planning approval.

The processes for these classes are described in Sections 8.3.1 through 8.3.3, below.

There will be no fees charged for Heritage Permits. Fees for Building Permits and Site Plan Approvals will be the same for respective non-heritage applications.

In addition, Cultural Services will review applications for zoning amendments and applications to the Committee of Adjustment, for Minor Variances and Consents to Sever or Convey Property in the District. These are not heritage permits, but are a service to applicants, allowing them to be aware of heritage issues prior to making an application for a Building Permit (Heritage).

Refer to Section 8.7 for checklists for applications in the various classes.

In addition, Council delegates authority for review and approval of smaller scale non-controversial Heritage Permits to City staff and/or Heritage Vaughan. Such delegated reviews and approvals are to be reported to Council. If outstanding issues in an application cannot be resolved, Council will review the application, inviting deputations from the applicant prior to its decision.

These arrangements should minimize the time required for issuing Heritage Permits. Applications for building permits or Site Plan Review will be circulated for heritage review in the same way they are already circulated for planning, zoning, and other approvals.

In most cases, when Policies and Guidelines of the Heritage Plan are followed, there will be little or no delay.

PRE-REVIEW

To speed and simplify the permit process for all scales of work, applicants should become aware of the requirements for the work they propose to undertake. Cultural Services staff can give advice on the type of permit required, and provide guidance on interpreting Heritage Policies and Guidelines. Additional advice can be obtained from Heritage Vaughan, which may also be able to assist in historical and technical research. Good internet resources, for work on heritage buildings are listed in Section 9.3.2.

The City may require the applicant to engage a heritage consultant to provide advice to both the City and the applicant at the review stage. This may be appropriate for larger developments.

8.3.1 The Heritage Permit

This type of application is only used when no other permits are required for the work to be undertaken. The following list identifies some of the types of minor projects which require a Heritage Permit:

- new or different cladding materials for both walls and roofs;
- repair and restoration of original elements
- painting;
- new or different windows or doors;
- changes or removal of architectural decoration or features;
- introduction of skylights or awnings;
- masonry cleaning and repointing;
- new or extended fences;
- new or increased parking areas;
- patios located in the front yard;
- permanent lamp installations;
- television satellite dishes
- mechanical equipment that can be viewed from the streetscape;
- planting or removal of trees in the public right-of-way;
- hard landscaping, such as retaining walls, rock gardens, hard surfaced pathways, visible from the public domain
- all above-ground public works.

The list is not complete and any undertaking should be discussed with Cultural Services staff. In addition, applicants are requested to confirm their projects with the Building Standards Department to ensure that a Building Permit is not required. There is no fee for a Heritage Permit.

8.3.1.1 Exemptions

In keeping with Section 3.1.2 of this Plan, a Heritage Permit is not required for the following projects:

- any interior work;
- repair to roof, eavestroughs, chimneys; re-roofing using appropriate material listed in Section 9.8;
- caulking, window repair, weatherstripping, installation of existing storm doors and windows;
- minor installations, including, lighting and flagpoles;
- fencing, patios, small satellite dishes, garden and tool sheds, gazebos, dog houses and other small outbuildings that do not require a Building Permit and are not visible from the public domain;
- planting, and removal of trees smaller than 200mm caliper, and any other vegetation on private property.
- Extension of residential parking pads other than in front or flankage yards.
- Ramps and railings to facilitate accessibility and gates installed for child safety provided they are not visible from the public domain.
- Temporary installations, such as basketball nets, planters, statues, seasonal decorations.
- Repair of utilities and public works.

Before performing such projects, you require a Heritage Permit Clearance Letter from Cultural Services, to confirm that the work is in an exempted class.

8.0 Implementation

8.3.1.2 Heritage Permit Process

The procedure to be followed has been created to streamline and minimize the time and effort needed by the applicant to gain this approval. Council and Heritage Vaughan have delegated the approval of non-controversial Heritage Permits to Cultural Services staff.

Applicant:

- Confirms with Building Standards whether a Building Permit is required.
- Conducts and Pre-reviews project with Cultural Services Staff.
- Sends a letter describing the project to Cultural Services.

It is recommended that prior to the submission of an application for a Heritage Permit, the applicant consult with Cultural Services staff to determine whether the application will require a formal review by a member of the --Canadian Association of Professional Heritage Consultants (CAPHC). In all instances it is recommended that applicants consult with qualified professionals.

At the discretion of the City, a peer review of a project may be required. The applicant will be responsible for all fees associated with this peer review.

Cultural Services:

- Reviews application and grants it if non-controversial, or forwards to Heritage Vaughan for further review.
- Provides Heritage Vaughan with regular summaries of its actions on all applications.

Heritage Vaughan:

- Reviews forwarded applications, and either approves permit or refuses permit with comments.
- Informs Council, in its regular minutes, of Cultural Services and Heritage Vaughan actions on all applications, and forwards applications and reports to Council where outstanding issues cannot be resolved.

8.3.2 Heritage Permit with Building Permit

The *Ontario Building Code* requires that owners obtain a Building Permit for any work that involves structural changes, change of use, or change in occupancy loads. Types of projects requiring a Building Permit include:

- new construction or structural repairs to porches, chimneys, roofs, walls, etc.;
- demolition;
- commercial signage;
- chimneys
- porches
- additions to buildings (may also require site plan approval);
- new building construction (may also require site plan approval).

8.3.2.1 Heritage Permit with Building Permit Process

The City of Vaughan Building Standards Department requires that applicants for Building Permits or Demolition Permits must provide all necessary clearances from other departments, including Cultural Services, before the application process can begin.

A Heritage Clearance Letter or an approved Heritage Permit is required for all Demolition Permits or Building Permits within a Heritage Conservation District.

There is no fee for a Heritage Clearance Letter or Heritage Permit.

At the discretion of Cultural Services Staff, an applicant for a Heritage Permit for development that is not subject to Site Plan Control may be required to provide a letter prepared by a licensed architect who is a professional member of

the Canadian Association of Heritage Professional Consultants confirming that the proposed development conforms to the intent of the policies and Design Guidelines of this Plan. This process will be required for any developments having a significant impact to the overall Heritage Conservation District such as for applications along Major Mackenzie Drive and Keele Street, significant gateway areas to the historic core or large-scale developments.

Applicant:

- Confirms with Building Standards staff that a building permit is required. Confirms with development Planning Staff whether or not Site Plan Approval is required.
- Arranges for a pre-review with Cultural Services staff to confirm whether the proposed work requires a Heritage Clearance Letter or a Heritage Permit.
- Obtains Heritage Clearance letter, or completes Heritage Permit application, if required. See application checklists in Section 8.7, below.

Cultural Services:

- Reviews heritage aspects of the project.
- Issues Heritage Clearance Letter or Heritage Permit, if proposal complies with the Heritage Conservation District Plan, or forwards to Heritage Vaughan for further review.
- Provides Heritage Vaughan with regular summaries of its actions on all applications:

Heritage Vaughan:

- Reviews forwarded applications, and either approves permit or refuses permit with comments.
- Informs Council, in its regular minutes, of Cultural Services and Heritage Vaughan actions on all applications, and forwards applications and reports to Council where outstanding issues cannot be resolved.

8.0 Implementation

8.3.3 Heritage Permit with Site Plan Approval

Site Plan Approval is required, in addition to a Building Permit, for larger projects in the municipality. Generally, this will apply to new development and significant additions or alterations. Planning Staff can advise applicants when this approval is required. Requirements include detailed building plans and elevations, site plan, and landscape plan. Larger developments may require other supporting documents such as traffic impact studies, storm water management plans, and so on. In the District, the application is handled like an ordinary Site Plan Approval, with the addition of a heritage review. City Staff has been delegated the authority to approve smaller projects and minor amendments to existing site plan agreements. More complex Site Plan Approvals are always sent to Council for final decision.

8.3.3.1 Heritage Permit with Site Plan Approval Process

The ordinary process for Site Plan Approvals (Heritage) is outlined below:

Applicant

- Confirms with Planning Department Staff that Site Plan Approval is required.
- Arranges for a Pre-review discussion with Cultural Services and Policy Planning and Development Planning Staff.
- Applies for Site Plan Approval, describing the work to be performed. All Site Plan Approval applications in the District will be forwarded to Cultural Services.
- (See Application Checklist in Section 8.7.3, below.)

The submission of an application for a Heritage Permit that is subject to Site Plan Control shall include a letter prepared by a licensed architect who is a professional member of the Canadian Association of Heritage Professional Consultants confirming that the proposed development conforms to the intent of the policies and Design Guidelines of this Plan.

Development Planning / Urban Design:

- Reviews application and forwards to Maple Streetscape Committee for review of streetscape elements.

Cultural Services:

- Reviews application and grants a Heritage Permit if the proposal complies with the Heritage Conservation District Plan, or forwards to Heritage Vaughan for further review.
- Provides Heritage Vaughan with regular summaries of its actions on all applications.

Heritage Vaughan:

- Reviews forwarded application and either approves Heritage Permit, with or without conditions, or refuses Permit with comments.
- Forwards decisions, actions, and comments of Cultural Services Staff and/or Heritage Vaughan to Planning Department for inclusion in its report to Council on the application.

Maple Streetscape Community Advisory Committee:

- Reviews application for streetscape elements and forwards comments to Planning Department for inclusion in its report to Council on the application.

Council:

- Acts on Development Review Application on the basis of the Planning Department Report.

8.3.4 Review of Zoning Amendment and Committee of Adjustment Applications

Zoning Amendment and Committee of Adjustment applications do not deal with buildings or structures, per se, but with Zoning By-law issues, under the *Planning Act*. As such, they don't require a Heritage Permit. However, they are steps on the way to future construction. It's obviously inefficient, for both applicants and the Committee, to deal with a proposal that will run afoul of District Policies and Guidelines when it subsequently moves to the Site Plan Approval and Building Permit stage. For example, later revision of plans to comply with the District Plan might call for other Variances than those originally applied for.

For these reasons, applications for Zoning Amendments and Minor Variances and Consents to Sever or Convey at the Committee of Adjustment will be reviewed for compliance with the District Plan. Formally, these are comments to Council of the Committee of Adjustment. Pre-review discussions with Cultural Services Staff, described above for the various classes of Heritage Permits, are also a part of the application process for these applications. This allows applicants to be aware of heritage concerns, at the earliest possible stage of a project.

8.3.4.1 Process for Review of Zoning Amendment and Committee of Adjustment Applications

The ordinary process for this review is outlined below:

Applicant:

- Arranges for a Pre-review discussion with Policy and Development Planning and Cultural Services Staff.
- Completes standard application forms for permissions sought. All applications in the District will be circulated to Cultural Services.

Cultural Services:

- Reviews heritage aspects of application, and comments to Council or Committee of Adjustment.

8.0 Implementation

8.4 Resolving Issues and Appeals

The phrase “if outstanding issues cannot be resolved” appears in each of the heritage review processes listed above. The City is committed to making all reasonable efforts to resolve issues arising in the permit process, consistent with heritage policies and guidelines. And it is further committed to providing historical and technical assistance to applicants in preparing applications that will meet the requirements of the District Plan. Good faith on the part of applicants and reviewers should result in a resolution process that is conversational rather than confrontational.

It may be useful to hold on-site discussions with applicants regarding design and details. The inspection of physical conditions is extremely valuable in assessing what level of restoration should be reasonably expected, and to what extent the work will affect the heritage character of the streetscape. The City may require the applicant to engage a heritage consultant to provide assistance in resolving issues.

If issues remain unresolved and are forwarded for action by Council, deputations from the applicant and his representatives will be invited before a Council decision is taken. Council may also request testimony from City Staff or Heritage Vaughan, in addition to the reports which it will have received on the matter, as outlined above.

If Council decides to deny an application for a permit under the *Heritage Act*, the applicant may make a final appeal to the Ontario Municipal Board, as described in Section 44 of the Act. The Board has the authority to deny the appeal, or to grant it, with or without such conditions and terms as the Board may direct.

8.5 Plan Renewal

The Village of Maple Heritage District Plan refers to the past, but it is a plan for the future. The Plan recognizes that, while the future may to some extent be foreseen, it cannot be foretold, and that plans require ongoing review to meet changing conditions. The long-term success of the Heritage District depends on “keeping it fresh”.

8.5.1 Reviewing Bodies

Section 8.2, above, provides for a role in the review of Heritage Permit applications by the Cultural Services Department and Heritage Vaughan. In addition, depending on the scale and scope of proposed work, both bodies may be delegated powers of approval of applications. It is important that these bodies thoroughly understand Part V of the *Ontario Heritage Act*, and the Policies and Guidelines in this Plan, and that everyone involved works from the basis of the same understanding.

It is recommended that the City organize an orientation session for members of the reviewing bodies, to review the Act and this Study and Plan in proper detail. It is also recommended that similar sessions be held again, when the personnel turn-over of a reviewing body reaches 50%, and after any substantial amendments to the Plan, as described in Section 8.5.3, below.

8.5.2 Regular Review

The District Plan should be reviewed regularly by City Staff in consultation with Heritage Vaughan, to ensure that the Boundary, Policies, Guidelines, and administrative methods remain effective and suitable for changing conditions.

8.5.3 Amendments

The policies and guidelines of this Plan may be amended by by-law after consultation, amendment circulation to potentially impacted parties, and public notice. Minor administrative and technical changes to the Plan may be implemented by a resolution of Council.

8.6 Enforcement

The City will enforce the requirements of the District Plan using the regulatory provisions of the *Ontario Heritage Act*, the *Planning Act*, the *Building Code Act*, and the *Municipal Act*.

8.7 Public Awareness

Vaughan's Official Plan recognizes the importance of the preservation of heritage character in the Village of Maple. A successful Heritage District requires public awareness and participation, and a variety of steps should or might be taken to ensure the ongoing effectiveness of the District Plan. Among these are the following:

- Under Section 41.10.1 of the *Ontario Heritage Act*, the City Clerk must ensure that a copy of the Heritage Conservation District Designating By-law is registered at the appropriate land registry office.
- All City Staff whose work could potentially impact on the District should be informed of the Boundary, Policies, and Guidelines for the District. This should include not only departments that administer the District or do physical work in it, but also departments that are involved in promotion of the City, planning for special events, and so on.
- All property owners and tenants in the District should receive notice of the District designation and be given the opportunity to review or purchase copies of the District Study and Plan. The requirements for Heritage Permits should be explained in the notice.

8.0 Implementation

8.7 Public Awareness cont'd

- Heritage Vaughan should consider putting notices on vacant premises so that prospective tenants will be aware of the existence of the District and the need to inquire about requirements for any work on the premises.
- Copies of the Plan and Study should be sent to Heritage Vaughan, the B.I.A., the Historical Society, and other groups interested in heritage and town planning.
- Copies of the Plan and Study should be placed in all the major branches of the Vaughan Public Library for public reference and should be offered for sale to the public.
- Consideration should be given to physical demarcation of the District with Public Works. Street signs in the District might include a "Heritage District" tag. "Gateway" devices might reinforce the identity of the District.
- A system for marking heritage buildings should be instituted. The existing heritage plaque program for Part IV designations should be continued. Incised or engraved pavers in the sidewalk would be a simple and inexpensive way to mark other heritage buildings in the District, without involving private property.
- Ongoing public awareness of the District will be reinforced if local promotion and special events publicity makes mention of the heritage character of Village of Maple, and the existence of a Heritage District. An annual or semi-annual Heritage District newsletter, inserted in the local newspaper, might also be a cost-effective way to boost heritage awareness in the City.

8.8 Application Checklists

The following checklists are provided to assist applicants in obtaining permits, and to assist staff in conducting pre-review and evaluating the applications.

8.8.1 Heritage Permit Checklist

For minor work, not ordinarily requiring a Building Permit:

- Inspect the property description in the Record of the District's Built Form. Make note of any comments that indicate needed maintenance and repair. Proper maintenance and repair is the primary means of protecting the heritage character of the District. Applicants are strongly encouraged to include necessary maintenance tasks at the first opportunity.
- Show results of any historical research. For example: provide a chip of original paint, if possible, when repainting; or provide copies of historic drawings or photographs when replacing or restoring elements such as windows, signs, and awnings.
- Read and understand any required technical material. For example: obtain a copy of the relevant Preservation Brief document, as listed in Section 9.3.2.
- Read and understand the relevant Policies (Section 6) and Guidelines (Section 9) in this Plan.
- In the case of more substantial work under a Heritage Permit, provide drawings that demonstrate compliance with the Policies and Guidelines of this plan and with other by-laws, such as the Sign By-law. For sign and storefront work, provide elevations at a minimum scale of 1:25, and details and profiles at a suitable large scale.

8.0 Implementation

8.8.2 Heritage Permit with Building Permit Checklist

For additions, renovation, and restoration:

- Inspect the property description in the Record of the District's Built Form. Make note of any comments that indicate needed maintenance and repair. Proper maintenance and repair are the primary means of protecting the heritage character of the District. Applicants are strongly encouraged to include necessary maintenance tasks at the first opportunity. Also make note of comments that indicate steps that could be taken to restore heritage features or to remove unsympathetic later work.
- Show results of any historical research. For example: provide copies of historic drawings or photographs, or show results of investigation of conditions underlying unsympathetic later work.
- Read and understand any required technical material. For example: obtain a copy of the relevant Preservation Brief document, as listed in Section 9.3.2.

For new construction, additions, renovation and restoration:

- Read and understand the relevant Policies (Section 6) and Guidelines (Section 9) in this Plan.
- Provide all documents ordinarily required for a building permit. These should include, as applicable for the scale of the work: outline specifications and drawing notes, indicating all materials visible from the exterior; elevations of all sides at a minimum scale of 1:50; elevations of storefronts at a minimum scale of 1:25; details and profiles, at a suitable scale, of cornices, signage and storefront elements, railings, trim, soffits and fascias, fences; an eye-level perspective, including adjacent buildings, for corner properties or free-standing buildings; a site plan showing building location, fencing, and planting. Elevations and perspectives should be "rendered" so that coursing, projecting elements, textures and fancy work are truly represented. Vertical dimensions should refer to those of adjacent buildings for alignment of horizontal elements. For projects requiring Site Plan Approval, include copies of approved drawings from the Site Plan Approval process.

8.8.3 Heritage Permit with Site Plan Review Checklist

- Read and understand the relevant Policies (Section 6) and Guidelines (Section 9) in this Plan.
- Provide all documents ordinarily required for a Site Plan Approval. These should include: site plan, at a scale suitable to the size of the property, showing location of the building(s) and buildings on adjacent properties, fencing, planting, sidewalk and driveway paving, and porches, decks, and other exterior elements; elevations of all sides, at a scale suitable to the size of the project, and including adjacent properties; an eye-level perspective, including adjacent buildings, for corner properties or free-standing buildings; outline specifications and drawing notes should indicate all materials visible from the exterior. Elevations and perspectives should be “rendered” so that coursing, projecting elements, textures, and fancy work are truly represented.
- Provide photographs of adjacent buildings for comparison with elevations and perspectives. Provide photographs of nearby heritage buildings of a similar type, to demonstrate the architectural sympathy of the proposed building.

Part D

Design Guidelines

9.0 Guidelines for Buildings and Surroundings

In its history and character, Maple is a distinct place in the larger municipality of the City of Vaughan. The City has recognized this special character by creating the Village of Maple Heritage Conservation District.

The purpose of these Design Guidelines is to help maintain the historic qualities that make up that sense of distinctness. They are intended to clarify and illustrate, in a useful way, the recognizable heritage characteristics found in the Village. They will serve as a reference for anyone contemplating alterations or new development within the Heritage Conservation District.

The Guidelines examine the past in order to plan for the future. They recognize that change must and will come to Maple. The objective of the Guidelines is not to prevent change, but to ensure that change is complementary to the heritage character that already exists, and enhances, rather than harms it.

Guidelines:

- The intent of the Guidelines is to preserve and enhance the existing heritage character of Village of Maple, which is widely appreciated by the citizens
- It is recommended that design professionals with experience in heritage design and restoration be retained for work on significant heritage buildings in the District.



Looking south on Keele Street, with St. Stephen's Anglican Church on the left. Photograph from Vaughan Archives.

9.0 Guidelines for Buildings and Surroundings

The character of Maple consists of many elements:

Significant natural features include the park, a small tributary of the West Don River, the open spaces of the cemeteries and church yards, and the mature urban forest.

Significant cultural elements include the informal village plan, with its varied lot sizes and setbacks, rich planting, and almost 150 years of architectural history. The historic buildings serve to define the heritage character of the village.

These Design Guidelines are based on the concepts of preserving the existing heritage buildings, maintaining their character when they are renovated or added to, and ensuring that new development respects the qualities of place established by the existing heritage environment.

The Guidelines begin with a handbook of the architectural styles found in Maple. Over the years, many buildings have lost original detail such as trims, doors, and windows. The style book will be helpful to owners who want to restore original character, or who want to maintain what remains. It will assist in designing additions that respect the original style of the building. And it will provide a basis for **authentic** local historic references in the design of new buildings.

The stylebook is also a tool for looking at the existing heritage buildings, which offer the best guidelines of all: they are full-scale and in three dimensions. The best test of new work in the Village is whether or not it shows “good manners” towards its heritage neighbours and its neighbourhood.

The design Guidelines are divided into the following sections:

- 9.1 Architectural Styles, p. 58
- 9.2 Heritage Design & Details, p. 81
- 9.3 Existing Heritage Buildings, p. 94
Maintenance
Renovation
Additions
- 9.4 Existing Non- Heritage Buildings, p. 108
- 9.5 New Development, p. 110
Residential Areas
Commercial Core
- 9.6 Streetscape Work, p. 125
- 9.7 Landscapes, p. 132
- 9.8 Building Materials Checklists, p. 134

Architectural style means the identifying characteristics of construction as it has evolved under the force of changing technology and fashion. Before the industrial age, often minor details were custom-made for each building and it would be hard to find even two identical front door designs from the early 19th century.

Nonetheless, each period produced buildings that shared a design vocabulary, including elements of massing, composition, proportions, window and door details, and decorative elements. This section shows the principal styles that have appeared in Maple, both heritage styles and more recent ones. This section is necessarily brief and does not replace the real research needed for authentic work, as described in Section 9.3.2 and 9.5.1.

In the Guidelines that follow, reference is made to architectural styles for all types of buildings in the Village of Maple: existing heritage buildings, existing non-heritage buildings, and new development. The following pages show the characteristics of the local architectural styles.

Guideline:

Additions and alterations to an existing heritage building should be consistent with the style of the original building. New developments should be designed in a style that is consistent with the vernacular heritage of the community. All construction should be of a particular style, rather than a hybrid of many styles. Recent developments have tended to use hybrid designs, with inauthentic details and proportions; for larger homes, the French manor or *château* style (not indigenous to Ontario) has been heavily borrowed from. These kinds of designs are not appropriate for the Village of Maple.

9.1 Architectural Styles

9.1.1 Heritage Styles Residential Buildings

VERNACULAR "LOYALIST" COTTAGE 1800-1850

Kitchen Tail often added later, sometimes with a side porch.

Fieldstone foundations

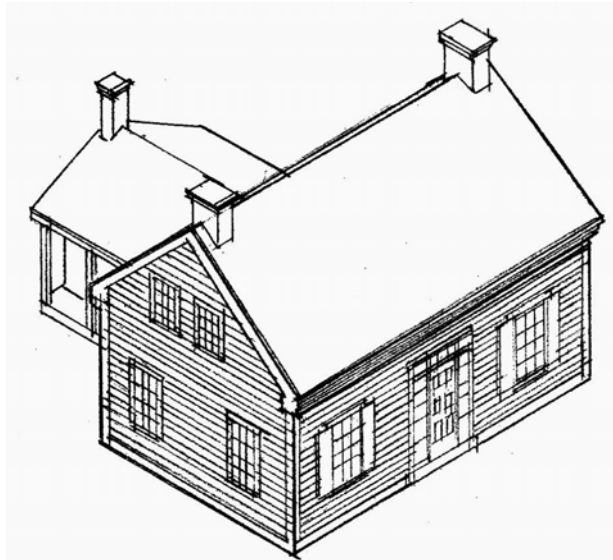

Brick chimneys, sometimes central

4" wood clapboard siding with wood corner boards; Brick or stone in some areas.

Wood fascia and eaves.

Symmetrical façade; central door with transom and/or sidelights.

Wood windows, double hung, 6 over 6 or greater.

Optional wood shutters.

The first of rural Ontario's two ubiquitous styles, the other being the Ontario Gothic Vernacular. The 1-1/2 storey design avoided the heavier taxation applied to 2-storey houses.

Typical Design Elements: for more information see Section 9.2

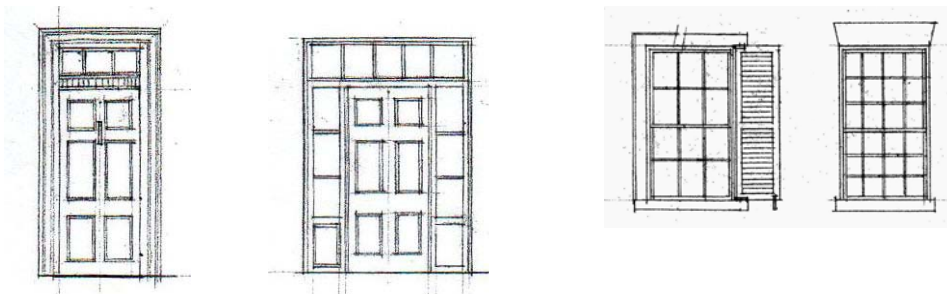

8 Church Street

9.1 Architectural Styles

9.1.1 Heritage Styles Residential Buildings

NEO-CLASSICAL 1800-1830

Side gable roof with moderate slope

Brick chimneys at side walls

Fieldstone Foundation

Symmetrical front elevation

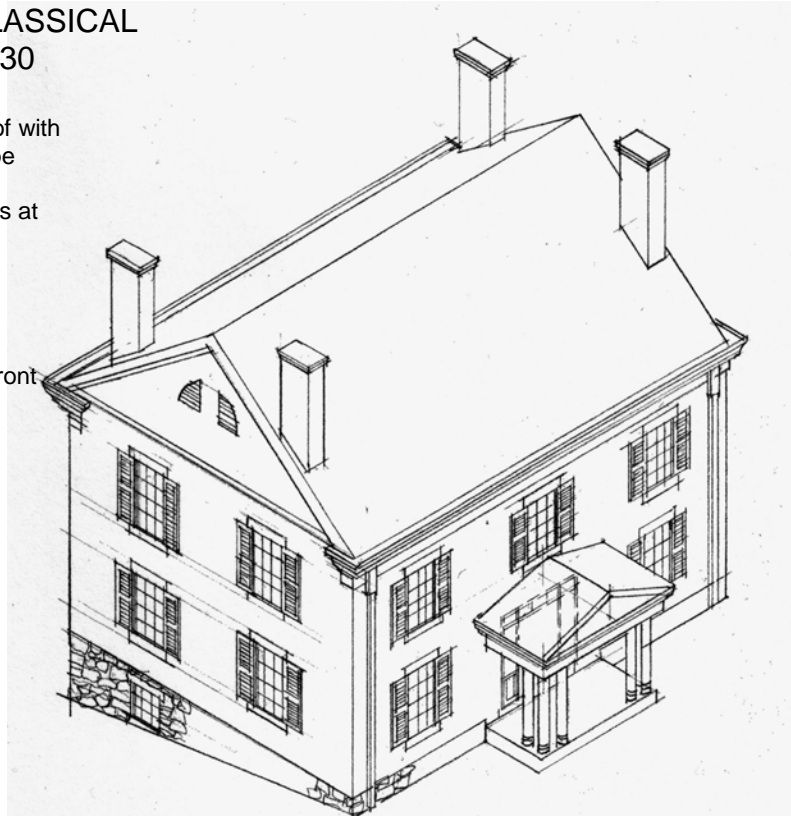

Usually brick or stone construction, less often wood clapboard.

Wood double-hung windows, often 12 over 12, tending to be larger than in Georgian style.

Classical details, such as pilasters at the corners, and "temple front" porch with classical columns.

Entry with sidelights and transom, often a fanlight. Classical surround is common.

Typical Design Elements: for more information see Section 9.2

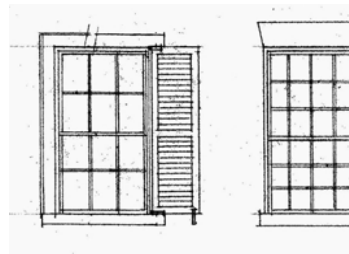
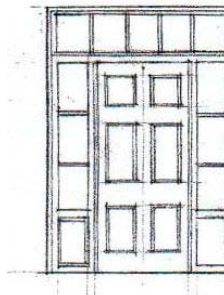
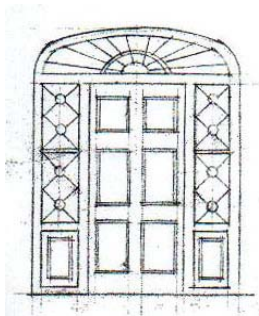

Beaverbrook House

9.1 Architectural Styles

ONTARIO GOTHIC VERNACULAR 1830-1890

- Kitchen Tail with room over.
- Wood side porch with sheet metal roof.
- Wood porch posts with decorative brackets.
- Fieldstone foundations.
- Red brick masonry with buff brick detailing—sometimes the reverse (polychromy).
- Optional front verandah, often with bell-cast roof.

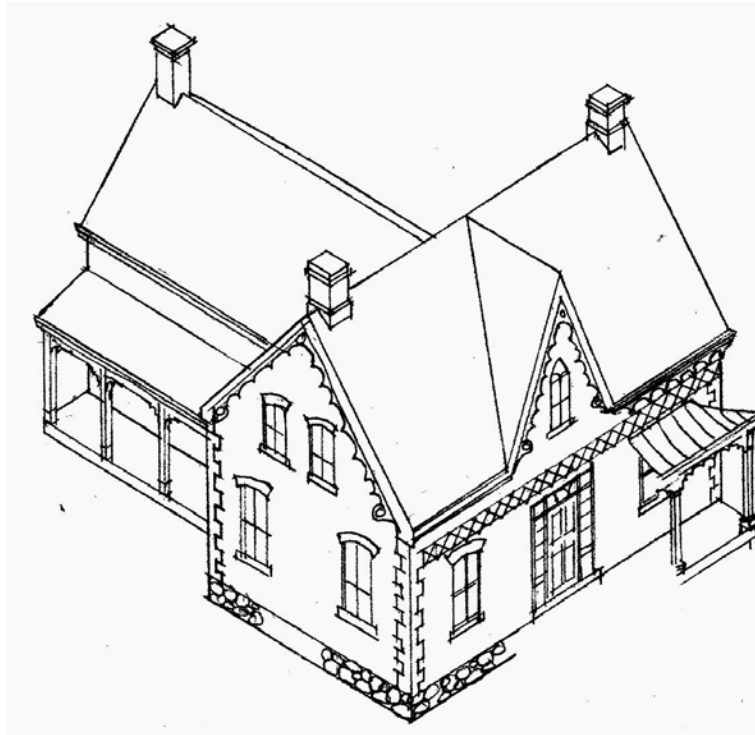

Brick chimney, corbelled polychrome.

Steep roof with “gingerbread” trim at gables; wood shingles or sheet metal roofing; Pointed ‘gothic’ window in central dormer gable.

Archetypal Ontario Gothic house, 1 ½ storeys, commonly brick construction, but also built of stone, stucco, and board and batten wood siding.

Symmetrical façade; central door with transom and/or sidelights.

Segmental arch wood windows, double-hung, 2 over 2.

9.1.1 Heritage Styles Residential Buildings

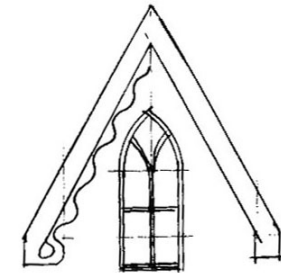

The central dormer is the most persistent feature in Ontario vernacular design. It is with us still. People will move into a bungalow and install a little peak in the verandah, above the front door. It makes the place feel more like home.

Typical Design Elements: for more information see Section 9.2

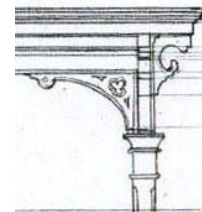
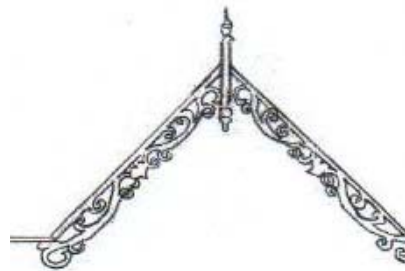
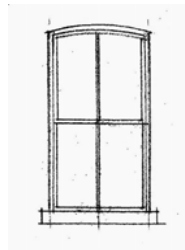
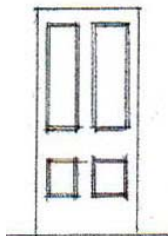

2150 Major Mackenzie Drive

9.1 Architectural Styles

VICTORIAN VERNACULAR 1850-1880

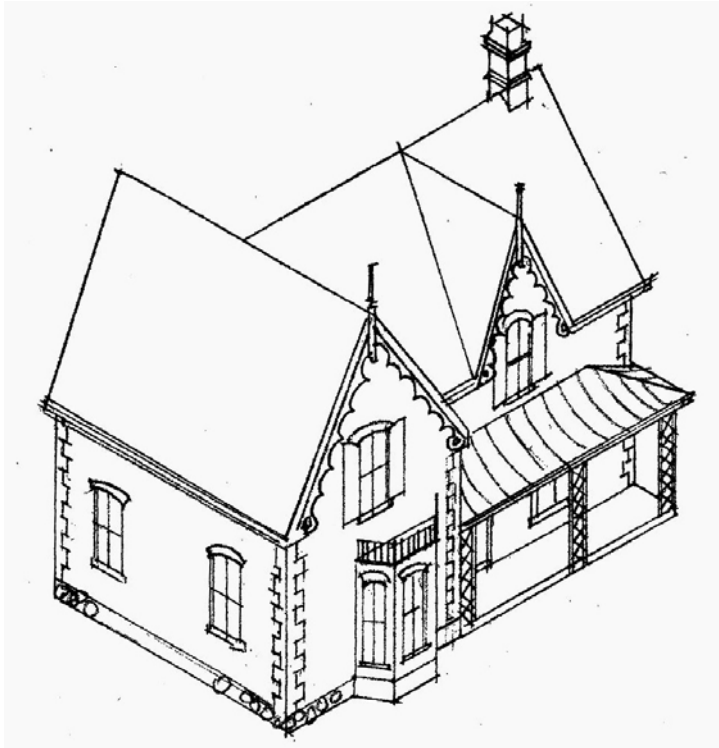

Brick chimney, corbelled polychrome.

Steep roof with "gingerbread" trim at gables; wood shingles or sheet metal roofing; Pointed 'gothic' window in central dormer gable.

Polychrome brick construction or board and batten siding (Carpenter Gothic).

Asymmetrical façade, main front-gabled bay often has a bay window.

Segmental arch windows, 2 over 2; optional shutters.

Verandah with wood posts and decorative brackets, or trelliage.

9.1.1 Heritage Styles Residential Buildings

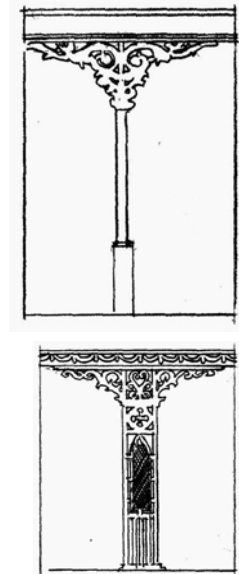

Typical Design Elements: for more information see Section 9.2

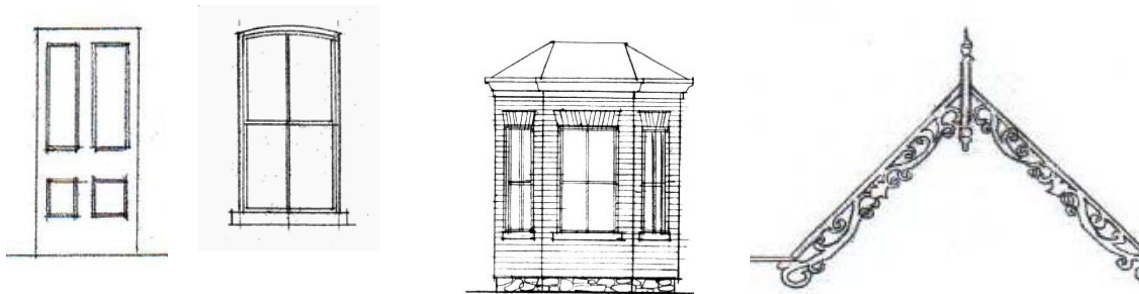

1 Jackson Street

9.1 Architectural Styles

SECOND EMPIRE
1855-1880

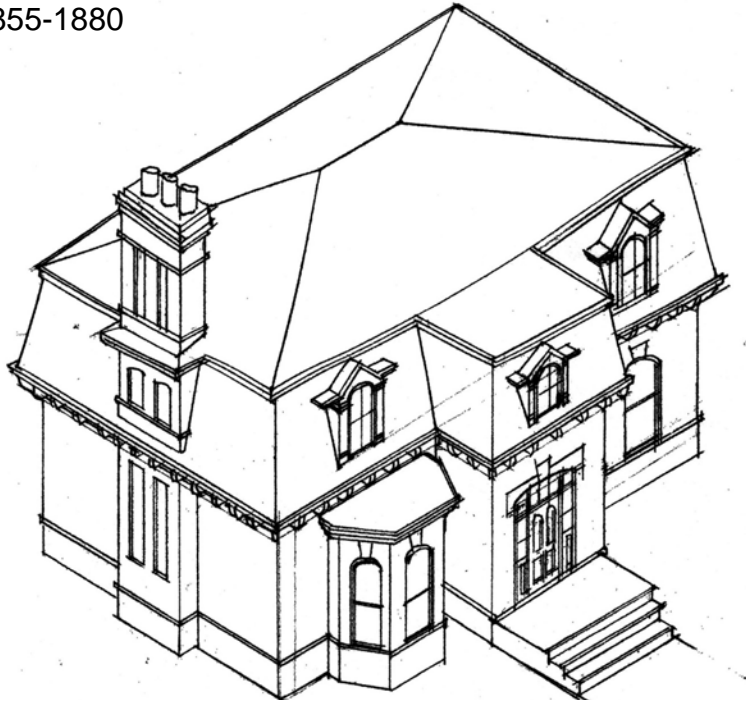

Mansard roof in shingle or slate.

Elaborately detailed dormers.

Decorative masonry work.

Large brackets at eaves.

Round-head or segmental-arched double-hung wood windows. 1 over 1 or 2 over 2.

Bay windows.

9.1.1 Heritage Styles Residential Buildings

Typical Design Elements: for more information see Section 9.2

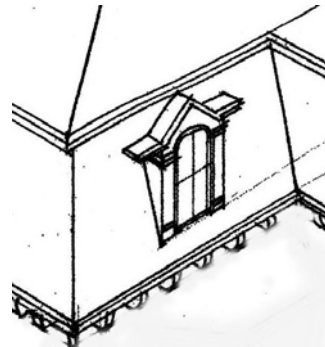
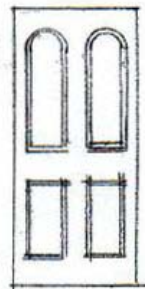
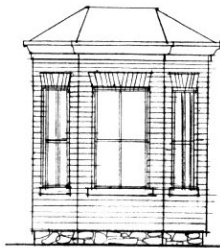

2333 Major Mackenzie Drive

9.1 Architectural Styles

9.1.1 Heritage Styles Residential Buildings

QUEEN ANNE REVIVAL 1885-1900

Steep gabled roof, often 12:12 slope.

Slate shingles often patterned.

Elaborate wood brackets, wood lattice work.

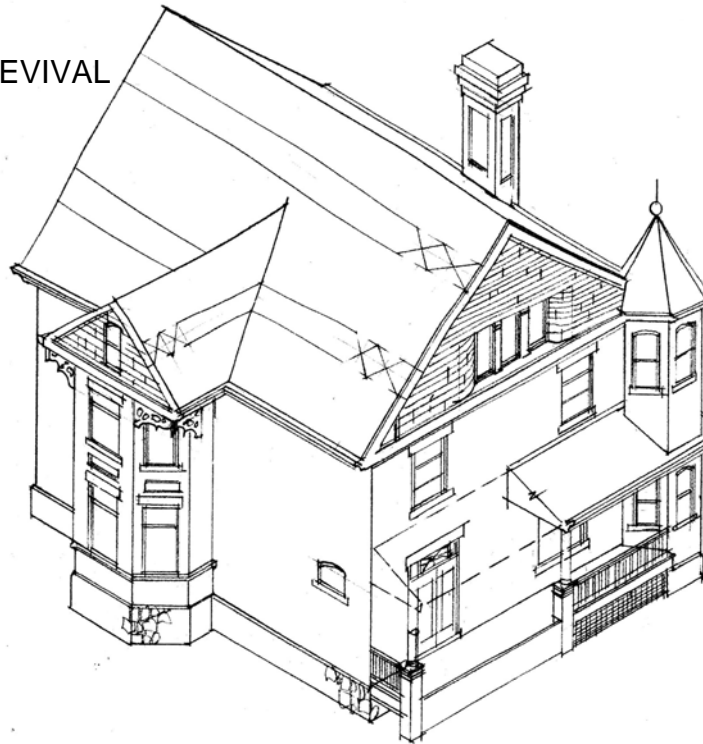

Brick construction.
Brickwork elaborately detailed.

Gable ends of shingles or tiles, often patterned.

Wide use of patterns in shingles, brickwork, and woodwork.

Asymmetrical plan, with turrets and bay windows.

Large double-hung windows, often with short upper sash.

Leaded and/or stained glass in transoms and upper sash..

Front porch or verandah.

Typical Design Elements: for more information see Section 9.2

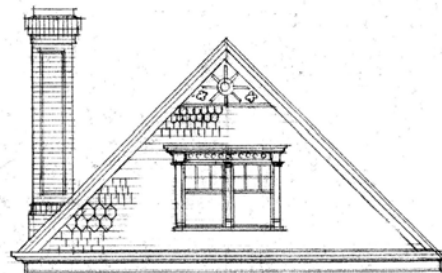
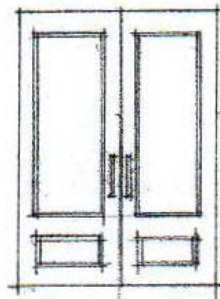
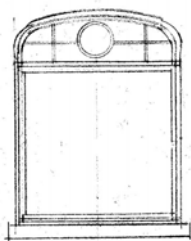

2126 Major Mackenzie Drive

9.1 Architectural Styles

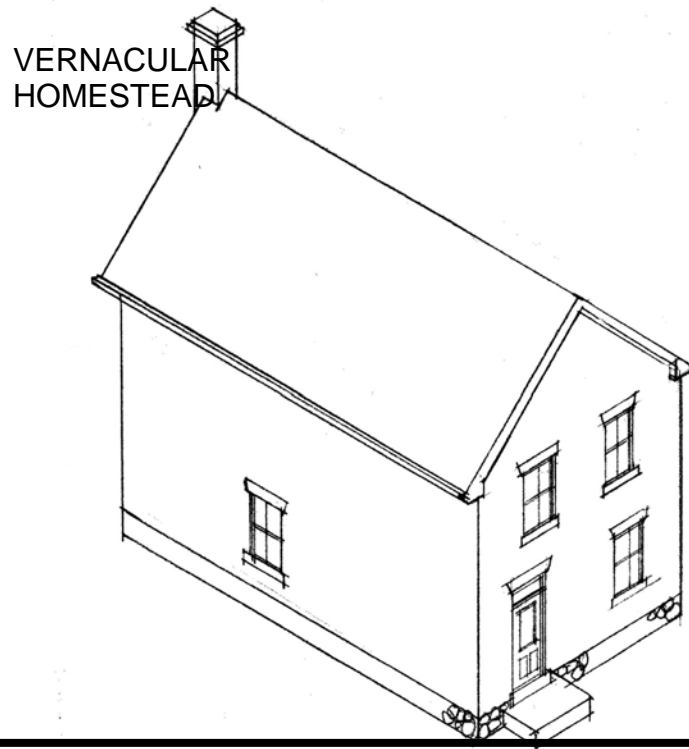

9.1.1 Heritage Styles Residential Buildings

Front-facing gable with steep roof, 12:12.

Two bays wide, with entrance and stair to one side. Plan has greater depth than width.

Detailing is simple.

Full-width verandah is common

Square headed openings.
Double-hung windows, 1/1 or 2/2.

May be clapboard, brick or stucco.

Typical Design Elements: for more information see Section 9.2

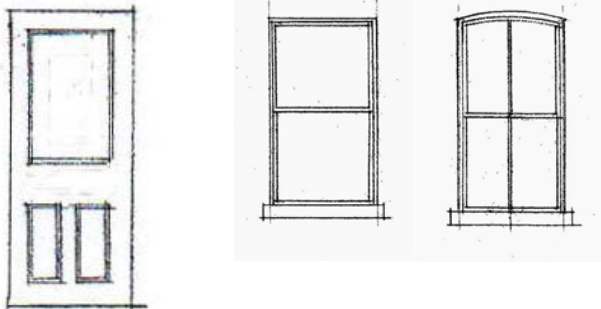

6 Richmond Street

9.1 Architectural Styles

9.1.1 Heritage Styles Residential Buildings

Four-square 1900-1920

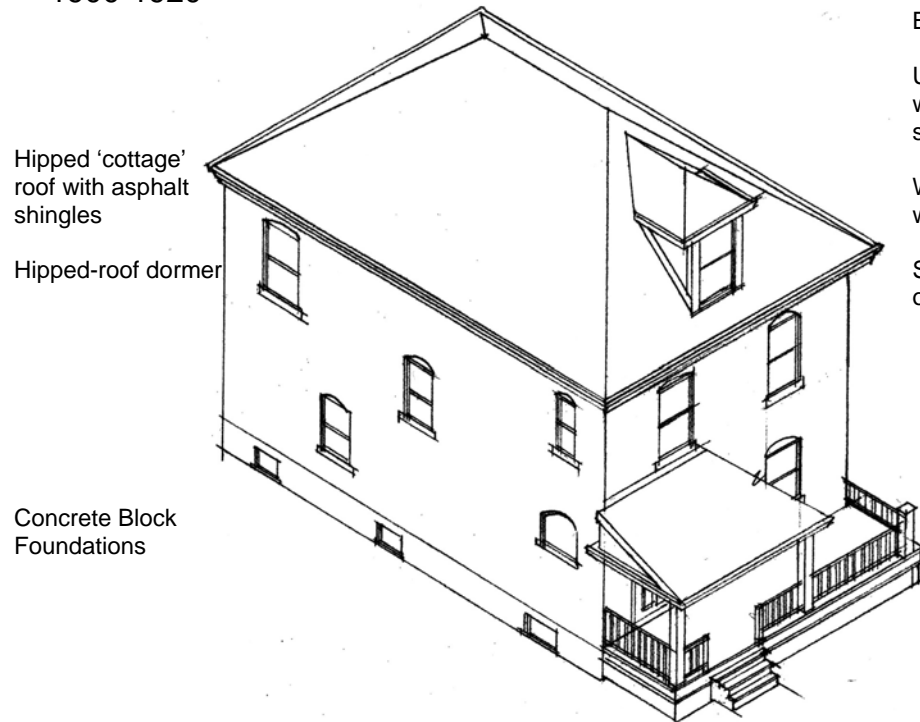

- Brick construction.
- Usually 2 bays wide with entrance to one side.
- Wood double-hung windows, 1 over 1.
- Simple wood porch or verandah.

Typical Design Elements: for more information see Section 9.2

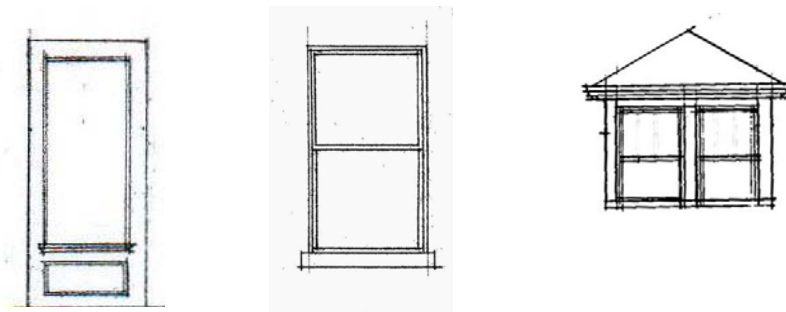

9.1 Architectural Styles

Edwardian
Classic
1900-1920

Low-slope hipped
'cottage' roof with
asphalt shingles

Hipped-roof dormer
or low-slope gable
in attic.

Non-symmetrical
Plan and Façade.

Concrete Block
Foundations

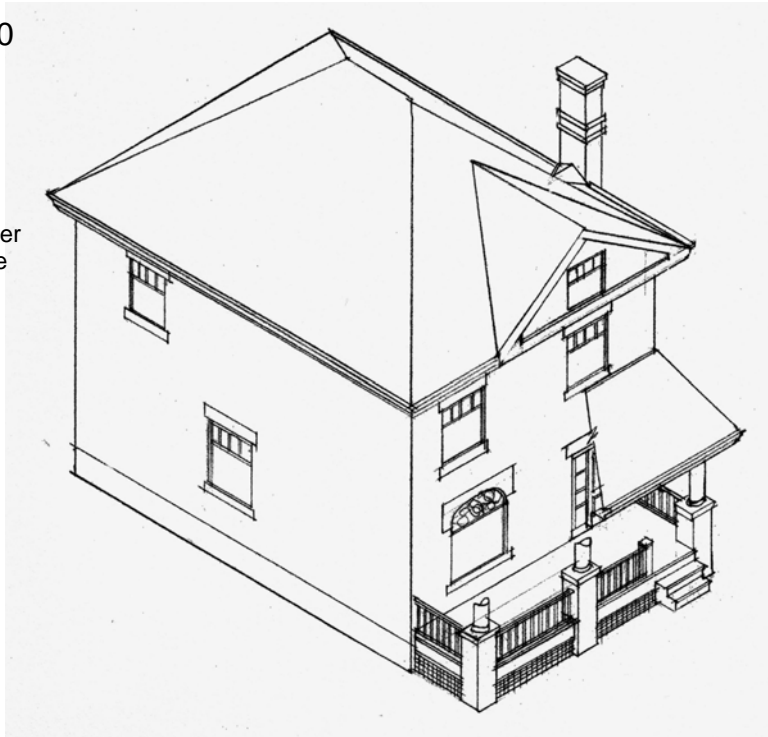

Brick construction.
Elaborate brickwork.

Wide wood double-
hung windows, often
6 over 1
or 4 vertical over 1.
"cottage style".

Wood verandah with
classical columns on
brick piers

Main front room
window with
decorative transom
often with leaded
and/or stained glass.

9.1.1 Heritage Styles Residential Buildings

Typical Design Elements: for more information see Section 9.2

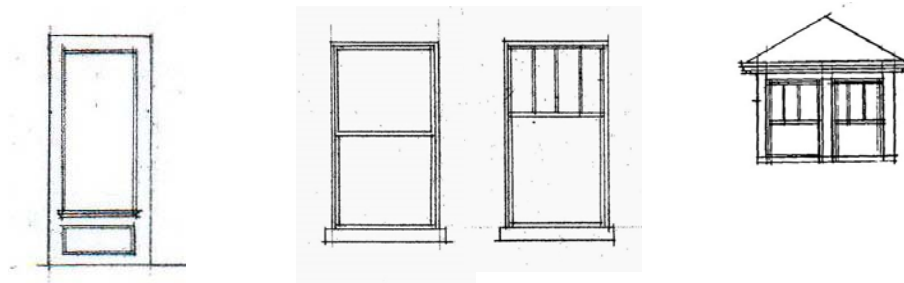

2174 Major Mackenzie Drive

9.1 Architectural Styles

A note on “Bungalows”.

The word “bungalow” has been applied to buildings of such a variety of sizes and shapes, that it causes architectural historians to shake their heads. John Milnes Baker, in his book *American House Styles*, says that bungalow is a type, not a style. In modern usage, the word has come to be used for almost any small house, regardless of its design. So there is some need to distinguish one kind of bungalow from another.

The term originates in a Hindi word meaning “house in the Bengal style”, and the originals were one-storey houses with low roofs and deep verandahs which provided needed airy shade in the heat of India.

The word entered the English language when the British in India adopted and elaborated the model for their army and colonial buildings, and they kept using the word as they built larger and fancier versions. The defining features remained the low roofs and the verandahs.

In North America, the term was first applied to small houses in the Craftsman style originally developed in California around 1900. These were 1- and 1-½ storey houses, with low-sloped roofs, wide eaves with the rafter tails exposed, and a deep front porch or verandah. Craftsman bungalow plans tended to be fairly open, with living and dining rooms flowing together, and perhaps a breakfast nook integrated with the kitchen.

The Craftsman bungalow was adopted as a model for mass-produced housing by builders across the continent between 1915 and 1930. The Builders’ bungalow retained the massing, but the Craftsman details were scaled back or eliminated.

By the late 1930s, “bungalow” had come to mean any small house that we don’t have another word for. The Cottage bungalow usually reverted to the hipped roof of the Bengali original, and in urban settings was sited with the narrow side facing the street. The Ranch bungalow (another California development) turned its long side to the street, on the larger lots of post-World War II suburbia.

The varieties of the North American bungalow are described in later sections below.



The original version of the bungalow, this one in Ceylon.



A British colonial bungalow in India, 1896.



Kalaketty Estate Bungalow
Copyright Home Stage
A very grand early 20th Century Bungalow in India.

9.1 Architectural Styles

ARTS AND CRAFTS 1900-1930

Gable or "Jenkins-head" (partially hipped) roof.

Bay windows tend to be square.

Brick or Concrete Block Foundations

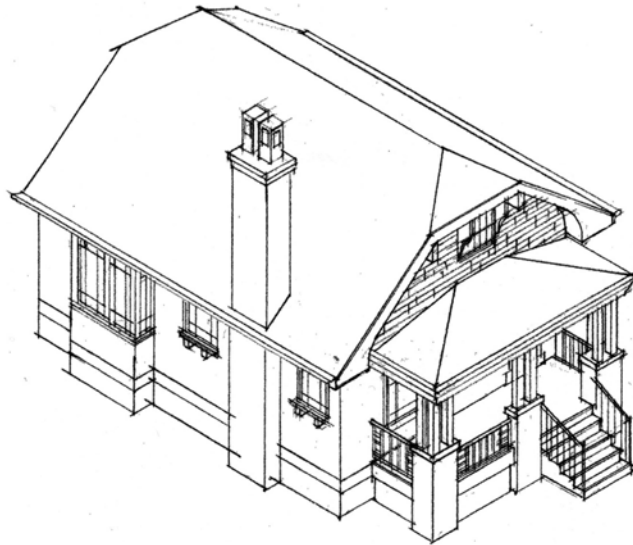

1 or 1-1/2 storey house.

Brick ground floor construction is common, with gable ends of cedar shingles

Asymmetrical plan, with entrance to one side.

Wood double-hung windows. Elaborate glazing patterns, sometimes leaded.

Verandah is a dominant design feature.

Rafter tails often exposed, and cut into decorative shapes.

9.1.1 Heritage Styles Residential Buildings

Typical Design Elements: for more information see Section 9.2

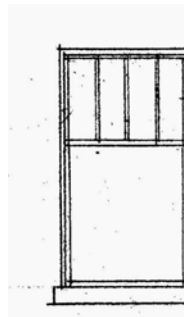
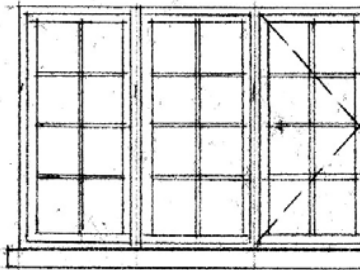

18 Richmond Street

9.1 Architectural Styles

9.1.1 Heritage Styles Residential Buildings

CALIFORNIA BUNGALOW 1900-1930

Side gable roof, with long front slope covering full width verandah.

Wide front-gable dormer.

Concrete block foundation.

Non-symmetrical Plan and Façade.

Concrete Block Foundations

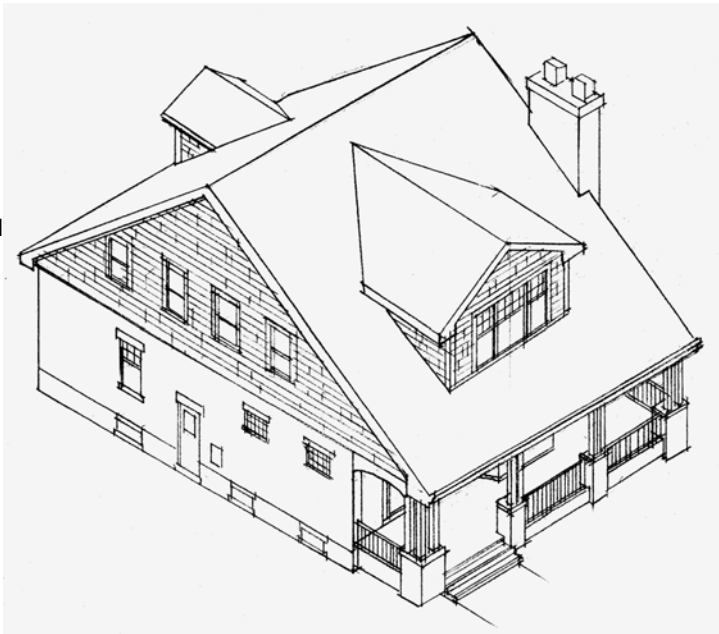

Usually brick ground floor, with cedar shingle gable ends and dormers.

Verandah usually supported by wood columns on masonry piers.

Wood double-hung windows, often 6 over 1 or 4 vertical over 1, "cottage style".

Typical Design Elements: for more information see Section 9.2

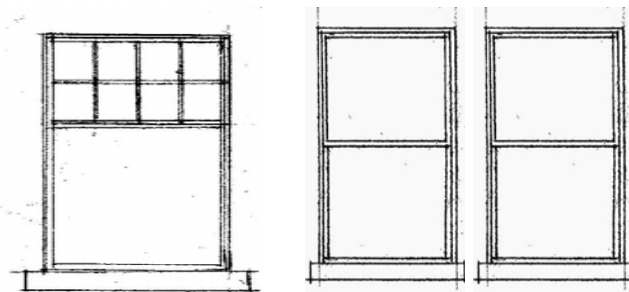

10128 Keele Street

9.1 Architectural Styles

AMERICAN COLONIAL REVIVAL 1900-1950

Steep gable roof.

Variety of roof plans, with front-gable bays or dormers.

Concrete Block Foundations

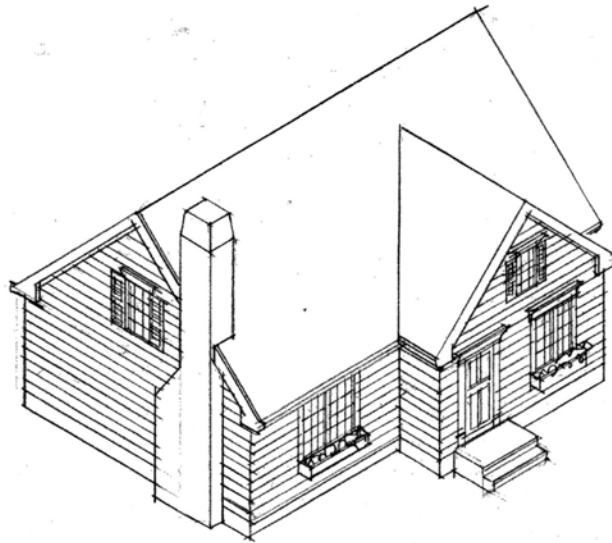

1 to 2 storey houses, often with asymmetrical plan.

Brick, clapboard or shingle siding.

Wood double-hung Georgian windows, often 6 over 6 or 8 over 8. Windows often paired.

Detailing fairly faithful to Georgian precedents..

9.1.1 Heritage Styles Residential Buildings

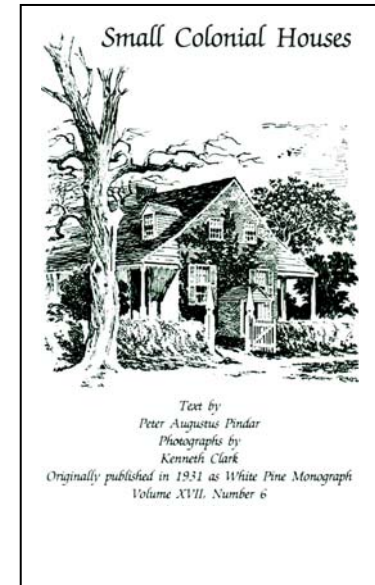

Typical Design Elements: for more information see Section 9.2

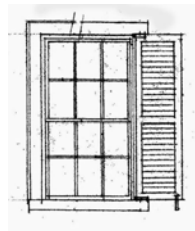
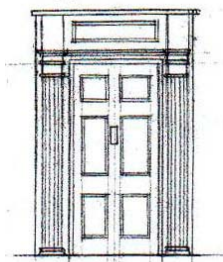

9796 Keele Street

9.1 Architectural Styles

9.1.1 Heritage Styles Residential Buildings

DUTCH COLONIAL
REVIVAL
1900-1930

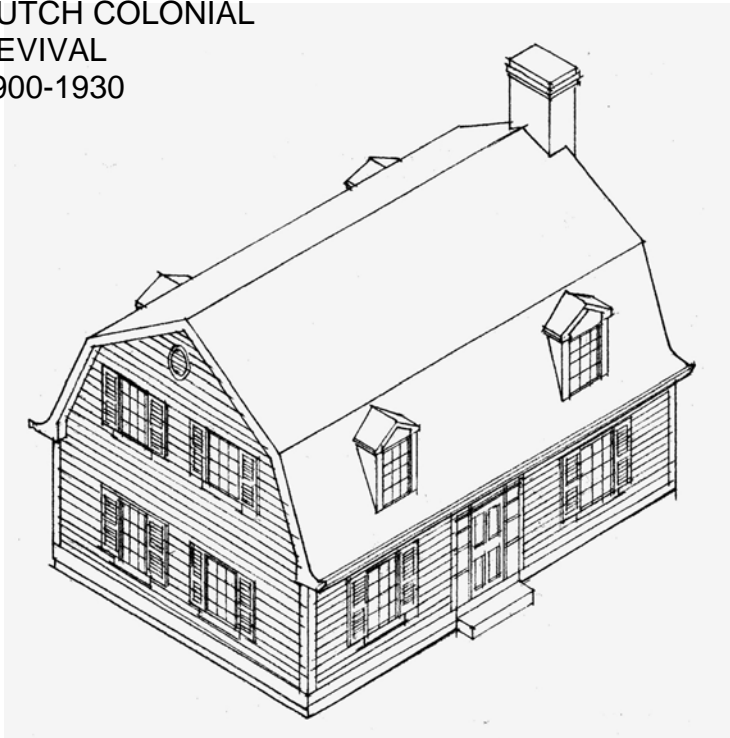

Usually 1-1/2 storeys, brick or wood clapboard siding.

Gambrel or “barn” roof provides increased second floor area. Often wood shingles.

Centre-hall symmetrical plan is common..
Asymmetrical plan, with gambrel-end facing the street, used on narrow lots.

Dormers, sometimes also with gambrel shape.

Wood double-hung windows, 6 over 6, wood shutters..

Typical Design Elements: for more information see Section 9.2

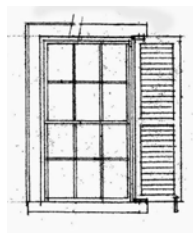
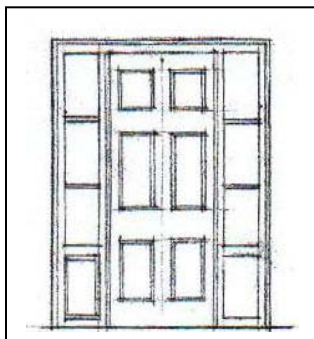

10108 Keele Street

9.1 Architectural Styles

"VICTORY" HOUSE 1939-1955

Classic mid-20th Century starter home, strongly derived from New England, hence Loyalist cottages.

Steep gable roof, 12:12, with asphalt or asbestos shingles.

May have gable dormers for upper floor, shed dormers often added later.

Foundations often on piles, with basements excavated later.

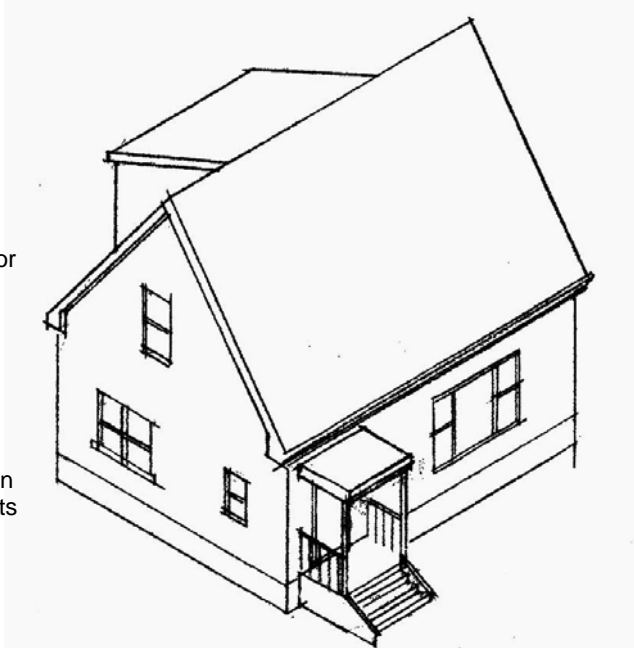

Variety of materials used:
Brick, stucco, clapboard, or asbestos siding.

Often large fixed 'picture' window flanked by narrow double-hung windows 1 over 1.

Compact plan 600 to 900 square feet. Non-symmetrical plan with entrance door to the side is usual in small plans. Larger plans may have centre door and centre hall.

Often a small entrance porch.

9.1.1 Heritage Styles Residential Buildings

This modest and stripped-down version of the Cape Cod cottage was produced in the thousands. Many were built near factories during the Second World War to house workers for the war effort that created Canada's manufacturing base. After the war, returning veterans built many more on their \$5000 housing allocation from the Department of Veteran's Affairs (DVA).

Typical Design Elements: for more information see Section 9.2

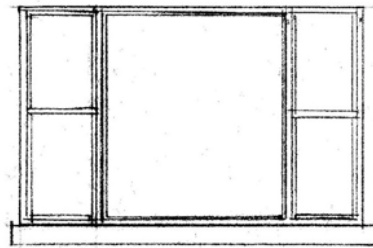
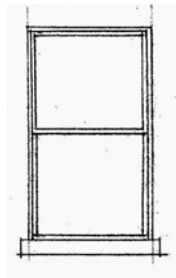

9797 Keele Street

9.1 Architectural Styles

HOTELS AND INNS 1850-1880

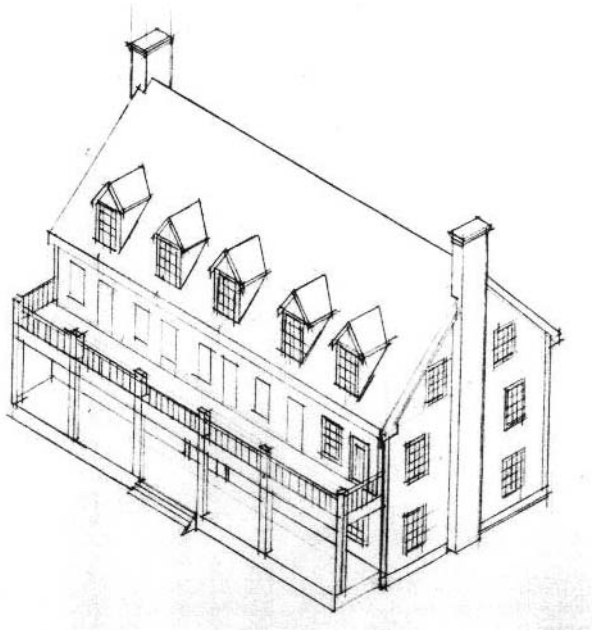

Usually 2 or 3 storeys with full-width front porch—commonly with balconies above

Usually frame construction in villages, sometimes brick in larger towns.

Side-gable roof was most common, with optional dormers.

Usually there was a stable alongside, for the travellers' horses and wagons .

9.1.2 Heritage Styles Commercial Buildings

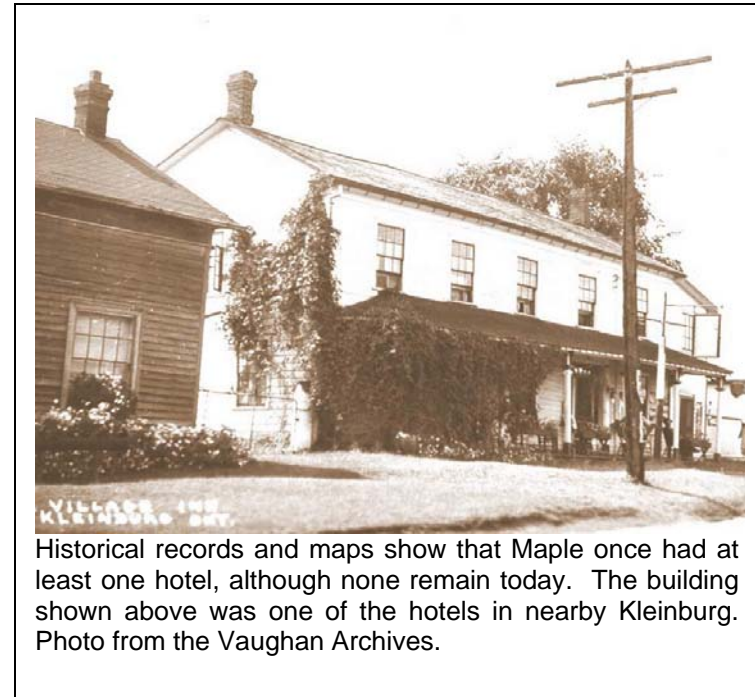

Historical records and maps show that Maple once had at least one hotel, although none remain today. The building shown above was one of the hotels in nearby Kleinburg. Photo from the Vaughan Archives.

9.1 Architectural Styles

VERNACULAR VILLAGE SHOP 1850-1910

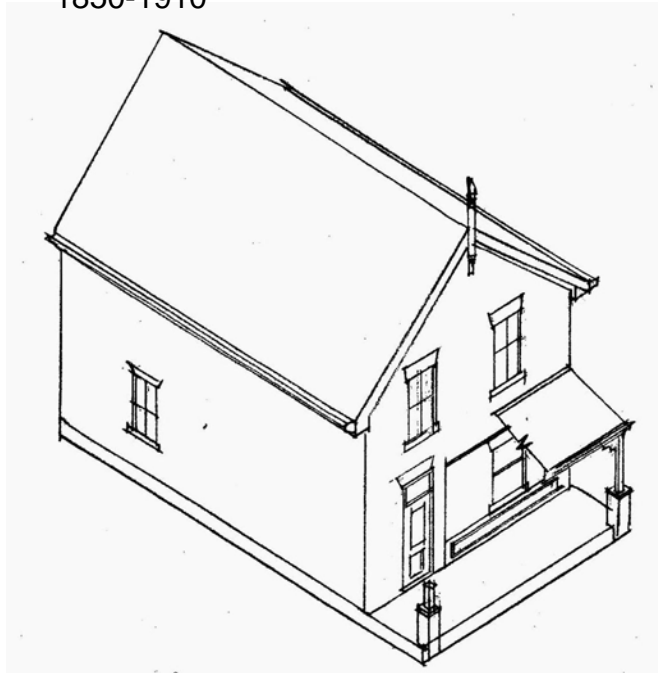

Usually a front-gabled frame building, similar to a homestead house. Often built with a false-front (boomtown style).

Typically built with shop below and living quarters above or behind.

Display window ranged from a slightly wider ordinary window, to a full-fledged shop-front as found in town shops.

Front porch, perhaps with sign on top, was very common.

9.1.2 Heritage Styles Commercial Buildings

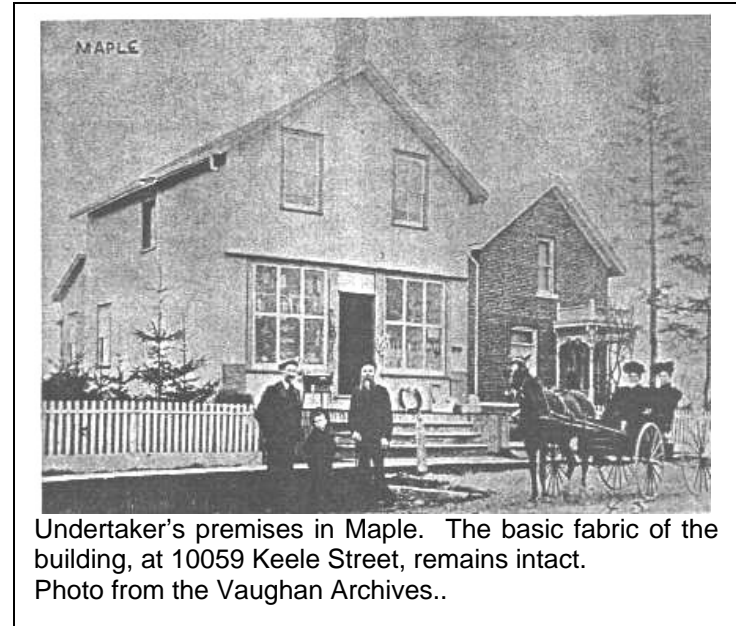

Typical Design Elements: for more information see Section 9.2

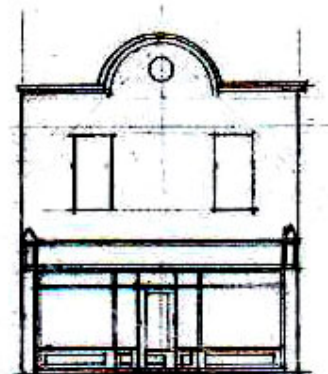
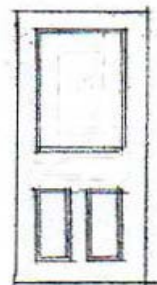
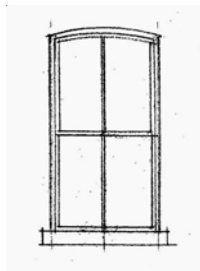

9.1 Architectural Styles

VERNACULAR TOWN SHOP 1880-1910

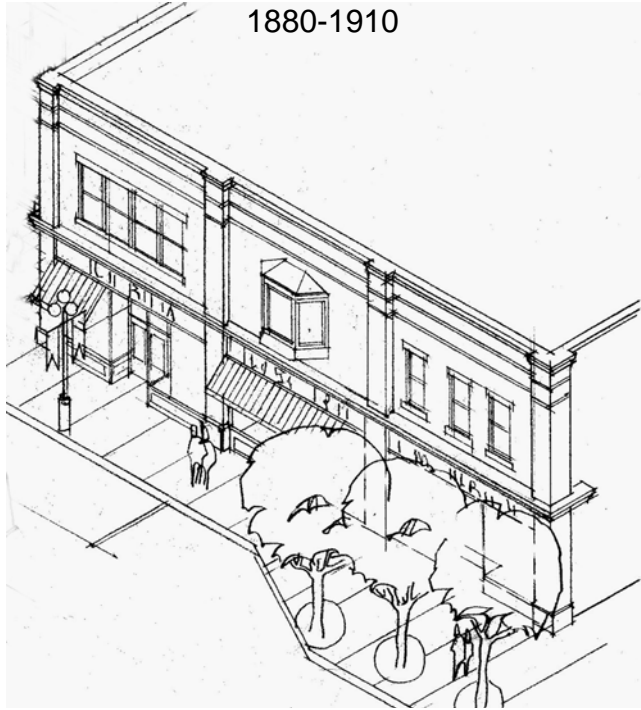

Two to three-storey buildings.

Early town shops might be wood-framed, but brick construction was more common by 1880, after many town fires throughout Ontario.

Built with uniform frontage at the street line.

Usually with flat roofs, sometimes with shallow side gable design.

Taller ground floor with high display windows, and full-width sign fascia above. Large retractable awnings.

9.1.2 Heritage Styles Commercial Buildings



The Bailey Store. A false front on a gabled village shop mimics the form of a town shop. Photo from the Vaughan Archives.

Typical Design Elements: for more information see Section 9.2

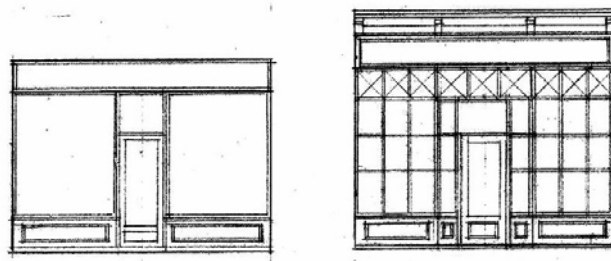

Lawrie Store 9994 Keele Street, with the Lawrie house behind.

9.1 Architectural Styles

GABLE- ROOFED TOWN-BARN OR STABLE SHOP 1850-1920

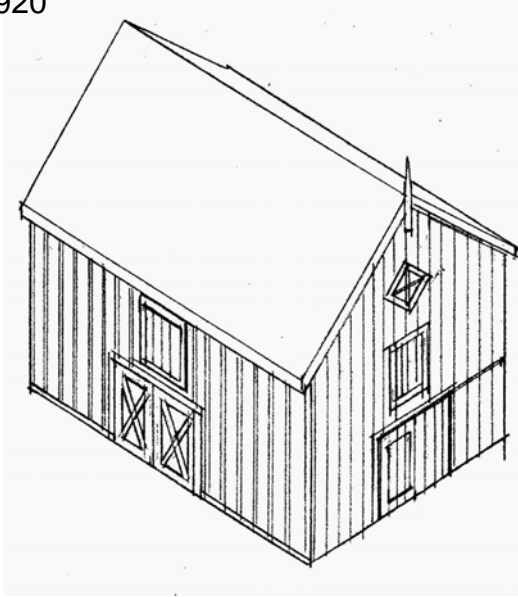

High-slope roof, wood shingle or sheet metal.

Timber frame with vertical wood siding, often slightly spaced for ventilation. Sometimes board and batten.

Upper loading door for hayloft. Sliding or hinged main lower doors, often with a smaller "man door" within it.

9.1.3 Heritage Styles Agricultural Buildings



Barn behind 9986 Keele Street

9.1 Architectural Styles

VERNACULAR BUNGALOW 1900-1955

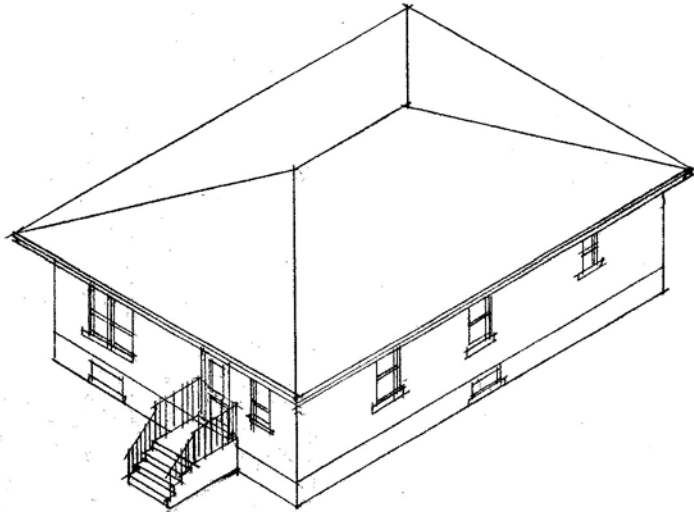

Usually of brick construction.

Wood double-hung windows, usually 1 over 1. Sometimes paired. Living room often had a "picture" window, with a wide fixed-glass window flanked by 2 narrow double-hung windows.

See "A note on bungalows", page 68.

9.1.4 Non-Heritage Styles Residential Buildings

Typical Design Elements: for more information see Section 9.2

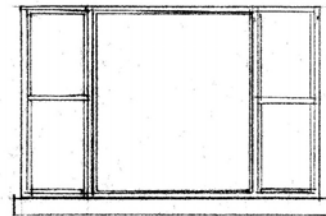
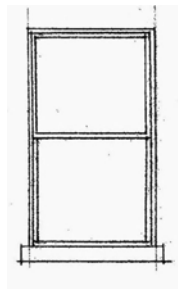

2146 Major Mackenzie Dr

9.1 Architectural Styles

RANCH HOUSE 1950-1975

9.1.4 Non-Heritage Styles Residential Buildings

Low slope roof, 4:12, hipped or gabled.

Asphalt Shingles.

Wide eaves, with 2-4 foot overhang

Large Chimney

Often accent bands of stone or 'angel stone'.

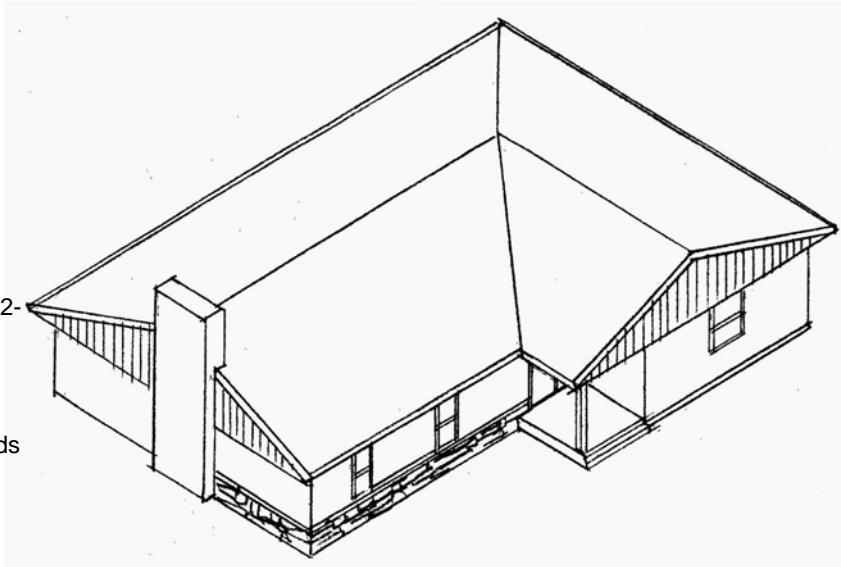

One-storey, informal plan.

Garage or carport usually attached.

Usually brick veneer on frame construction.

Large fixed picture windows in principal rooms, flanked by operable windows; double hung or casement.

Typical Design Elements: for more information see Section 9.2

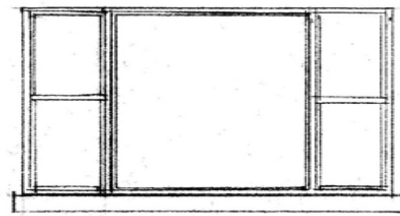
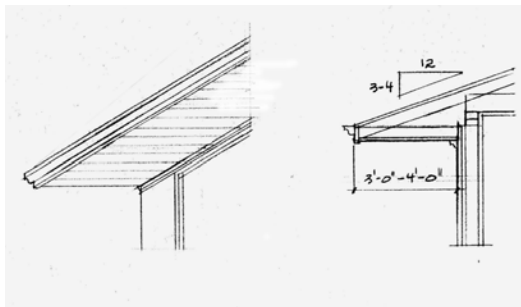

10138 Keele Street

9.1 Architectural Styles

POST MODERN ECLECTICISM 1980 TO PRESENT

9.1.4 Non-Heritage Styles Residential Buildings

Large high-sloped roof.

Usually two storeys high.

Elaborate chimneys are common.

Architectural elements borrowed from a variety of historical style. Elements are typically exaggerated in scale, particularly entrances, fanlights, and porches.

Mixture of materials: Stone base with brick or stucco above is common.

Attached or built-in garages are common.



9652 Keele Street

9.2 Heritage Design and Details

9.2.1 Introduction

The purpose of this Section is to provide further information and guidance about the design and construction of heritage buildings.

9.2.2 Composition

The elevations of heritage buildings, whether designed by an architect or by a builder using a “pattern book”, were usually laid out using geometrical principles and geometrically derived proportions. Knowledge of how heritage buildings were originally composed can be helpful in designing a new building that will fit well in the heritage context. Helpful sources of information are listed in Section 10.

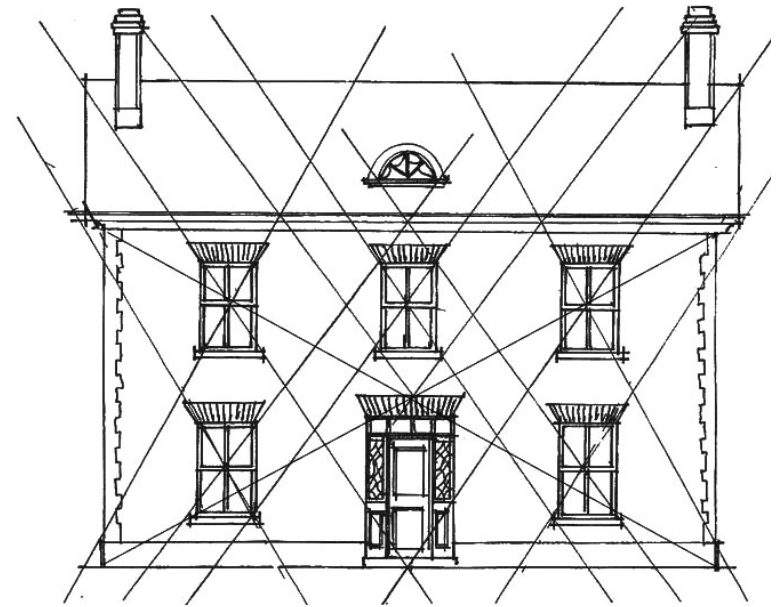

Geometry governed most heritage design. In this example, from Black Creek Pioneer Village, the diagonals of the window openings relate to significant elements in the elevation and to each other. The diagonals of the main wall relate to the windows and front-door keystone, as well.

If a building is pleasing to the eye, it is probably rich in such relationships.

Drawing by Steven Bell.

9.2 Heritage Design and Details

9.2.2 Composition Cont'd

The proportion of windows to walls and the proportions of individual window openings and window panes are an important aspect of composition.

Traditionally, windows are between 15 and 20 percent of a wall, and windows are taller than they are wide, usually with a ratio of 2:1 or more. In most heritage styles, individual window panes are also taller than they are wide.

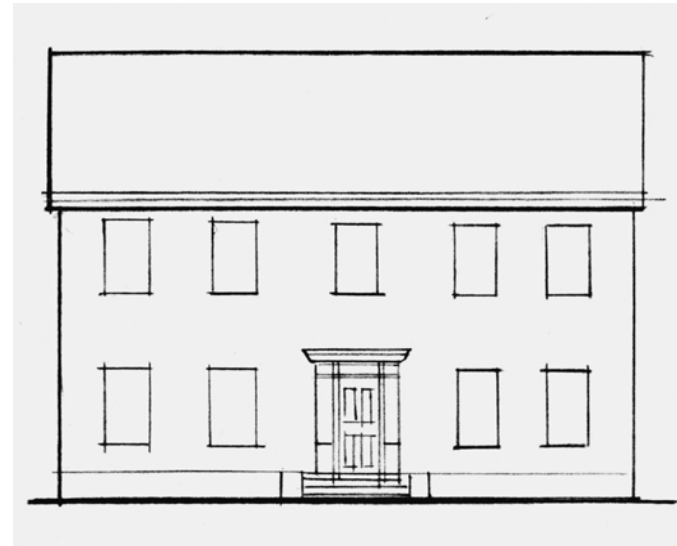

Appropriate: 15 to 20% opening is historically correct.

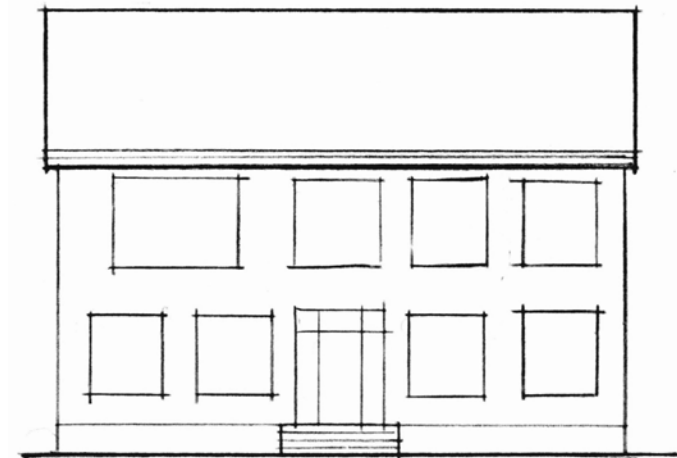

Inappropriate: 30 to 40% is excessive.

9.2 Heritage Design and Details

9.2.3 Entrances and Doors

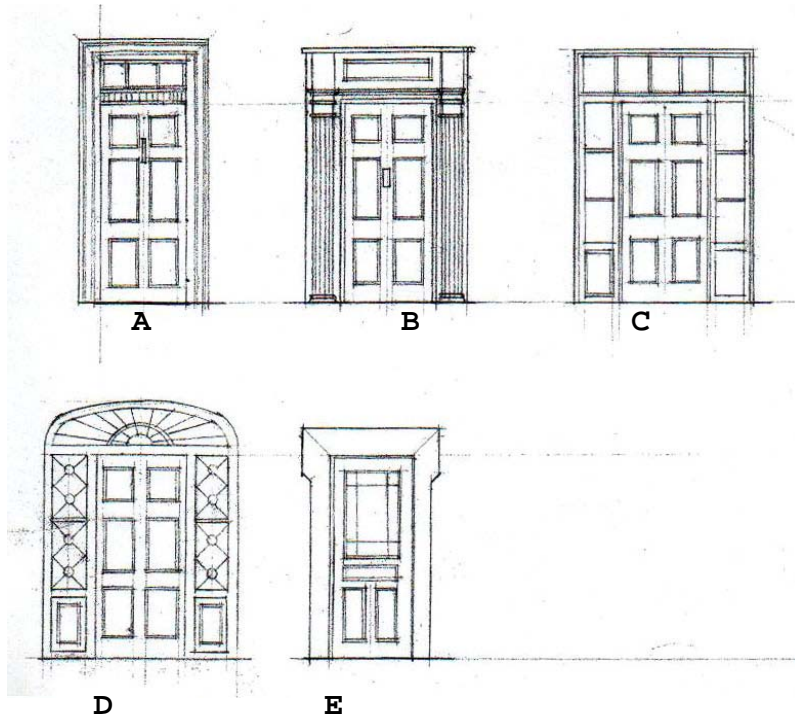

Entrances in heritage buildings are usually provided with some elaboration. In the simplest Georgian cottages this might only consist of fluted casings and a simple cornice, but a plain transom above the door was common.

Later styles made use of sidelights as well, which always had solid panels below the glazing.

The proportional scheme of the building governed the design, so that even ornate entrances did not overwhelm the building.

Entrance doors were not glazed until the Victorian era.

- A. Solid panel door with transom and wood casing.
- B. Solid panel door with classical cornice.
- C. Solid panel door with transom and sidelights.
- D. Solid panel door with decorative sidelights and fanlight transom.
- E. Wood panel door with decorative glazing and eared casing.

9.2 Heritage Design and Details

9.2.3 Entrances and Doors Cont'd

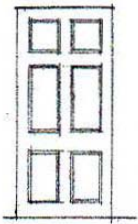

A

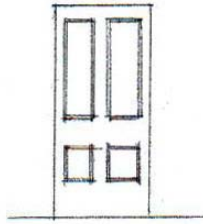

B

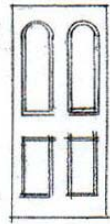

C

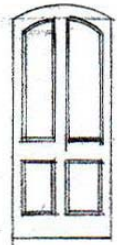

D

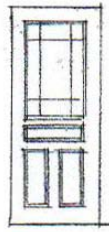

E

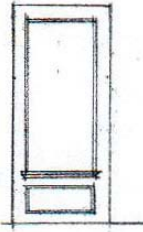

F

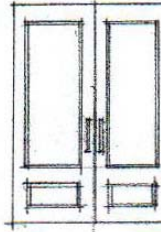

G

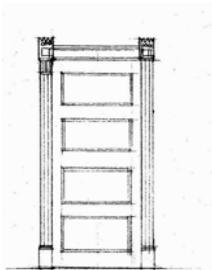

H

Log-cabin pioneers built simple plank doors, such as you would find on a barn, but as soon as skilled workers became available, doors were built in frame-and-panel construction.

Georgian doors tended to have 6 panels. The example shown at the top left is called a 'Cross and Bible' door, because the rails between the top four panels form a cross, and the two panels below are said to be an open book.

Later styles used 4-panel doors, with very tall top panels. These provide a vertical emphasis, in keeping with the Gothic Revival, Victorian Vernacular, and Italianate styles.

In the late 19th and early 20th centuries, the horizontal emphasis of Edwardian and Arts and Crafts styles led to doors with horizontal "ladder" panelling.

When large pieces of glass became available, around 1850, doors began to be glazed. In the simplest case, the two upper panels of a 4-panel door would receive glass, but the ability to glaze the full width of a door led to a variety of panel designs.

- A. Cross and Bible Door
- B. Four Panel Door
- C. Arched Panel Four Panel Door
- D. Arched-head Four Panel Door.
- E. Glazed Wood Panel Door.
- F. Glazed Wood Shopfront Door.
- G. Paired Glazed Wood Shopfront Door.
- H. Four Panel "Ladder" Door

9.2 Heritage Design and Details

9.2.4 Windows and Shutters

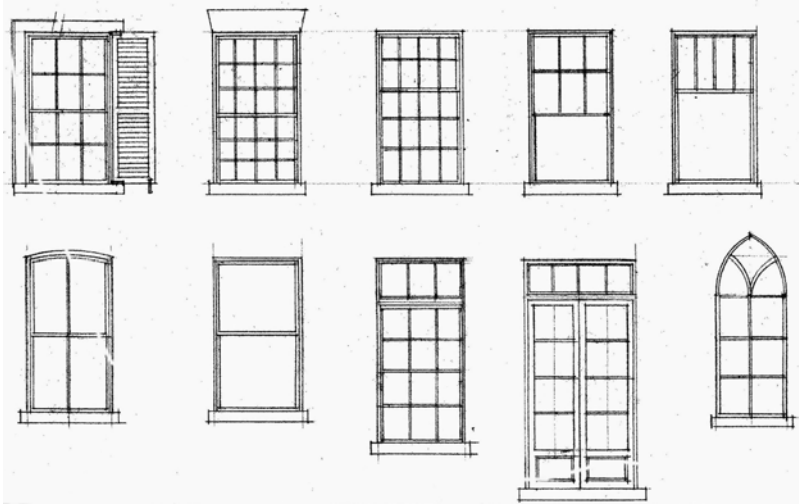

Most heritage styles used double-hung windows. These are described by the number of panes, or lights, in each sash. If there are 6 panes above and 6 below, it's called a 6 over 6, or 6/6 window.

Before around 1850 the size of available panes was small, and the number of lights was large. Typical Georgian windows were 12/12. As glass technology improved, larger glass led to 2/2 and then 1/1 windows.

Later styles, such as Edwardian and Arts and Crafts, made use of both large and small lights, and 6/1 and 8/1 windows became common.

As a general rule, windows had more height than width, and the individual lights shared that vertical proportion. Glass that is wider than it is high is found only in very wide single light sash.

Casement windows appeared in only a few styles. Some Regency windows could be called casements, though they are more like French doors, with sills barely above the floor. The Craftsman style was the first to use what we would call casements today.

Shutters were provided to secure windows from storms and damage, and they were designed and installed to close the window opening. They are hinged at the window jamb, and each shutter covers exactly half of the opening. Usually they were louvered.

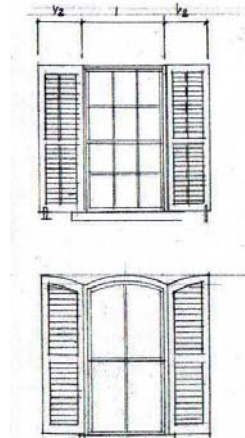

9.2 Heritage Design and Details

9.2.5 Bay Windows

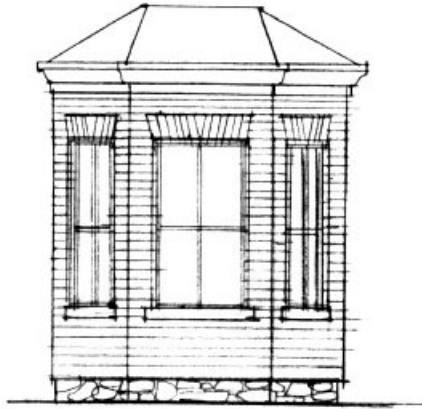

Victorian

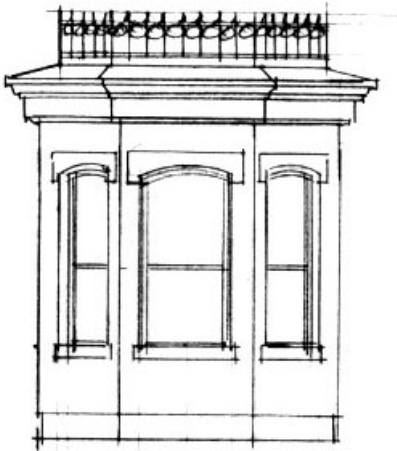

Victorian, Italianate,
Second Empire

Bay Windows provide visual interest on the exterior and create a well-lighted nook on the interior. They appear on a number of historic styles, but not all. There is a tendency to overuse them in new buildings, when they are not appropriate to the overall architectural style. Care should also be taken to use window shapes and glazing patterns suitable to the overall architectural style.

Most bay windows in most styles are angled, usually at 45 degrees, but the Arts and Crafts style, and some Victorian Vernacular buildings used square bays.

In Maple, most bay windows are on the ground floor only, and extend to the ground. Some Arts and Crafts houses have square bay windows that don't extend to the ground, as seen at 18 Richmond Street. A protruding bay high on a wall is called an oriel window.

9.2 Heritage Design and Details

9.2.6 Gable Ends

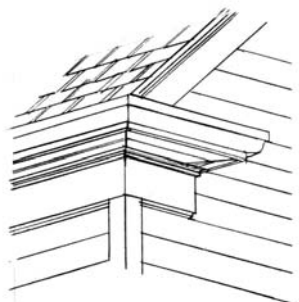

Classical Styles



Victorian Gothic



Queen Anne Revival
Gable Peak

The classically-based styles, such as Georgian and Classical Revival used fairly plain bargeboards. A plain board, with perhaps a small ogee moulding on the upper edge, was the most common design. The eaves would include a wooden gutter in the shape of a wide ogee-moulding. This shape was later replicated by sheet-metal eaves-troughs. Below this was usually a fascia board, sometimes with additional moulding at the top, or perhaps dentils. The fascia and mouldings typically turned the corner at the gable end as shown in the upper sketch, in what is called an eaves return.

The Victorian Gothic styles used elaborate bargeboards in a wide variety of forms—what has come to be called “gingerbread”. Sometimes these were sinuous shapes cut out on a scroll saw. In other cases pierced patterns were cut into a simpler board. A common feature was a finial at the peak, as shown in the middle sketch. There are often characteristic local styles in Victorian trim, and although Maple has some fine and elaborate gingerbread, historic photographs suggest that many houses had simple bargeboards, and used trim more freely at porch columns, and under porch eaves.

It is good practice to repair or replace historic gingerbread in the original pattern, using accurate dimensions. Historic drawings or photographs, or nearby local examples can be used as sources for an authentic design.

The Queen Anne Revival style tended to use built-up detail, with square panels and round medallions applied to a plain bargeboard. The peak of a gable was often given an ornate decoration of built-up work, as shown in the lower sketch.

9.2 Heritage Design and Details

9.2.7 Dormers

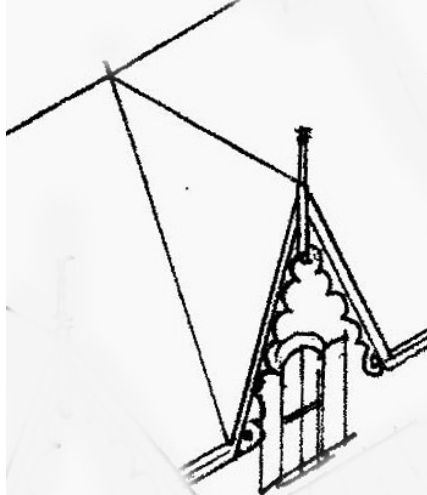

Victorian Gothic

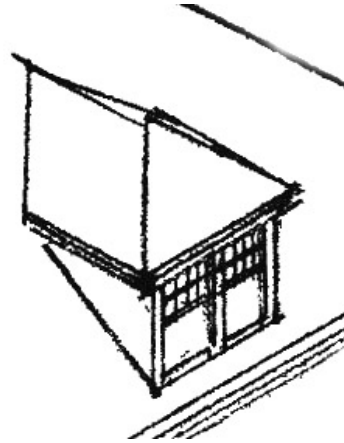

Edwardian.
Foursquare is similar, but uses simple
1 over 1 glazing

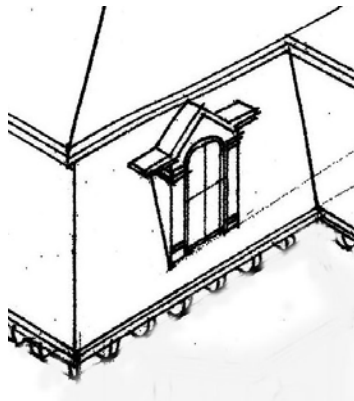

Second Empire

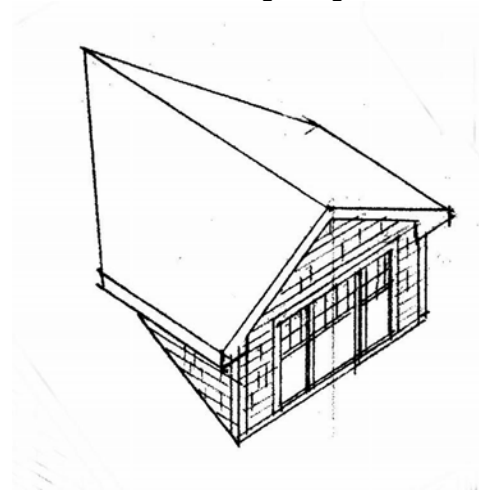

Arts and Crafts/California Bungalow

Dormers provide useful light in attic spaces, and as described in Section 9.1, the use of an attic avoided the higher taxes on a two-storey house in the early 19th Century.

Victorian Gothic dormers rise from the main wall of the house, and are not set back from the roof. When the bargeboard meets the main eaves they are usually considered gables rather than dormers.

In Maple, roof dormers appear on the Second Empire, Edwardian, Foursquare, Arts and Crafts, California Bungalow Styles. When designing new dormers, care should be taken that they are appropriate to the architectural style in all details: roof slopes, fascias, soffits, window shapes and glazing.

9.2 Heritage Design and Details

9.2.8 Porch Design

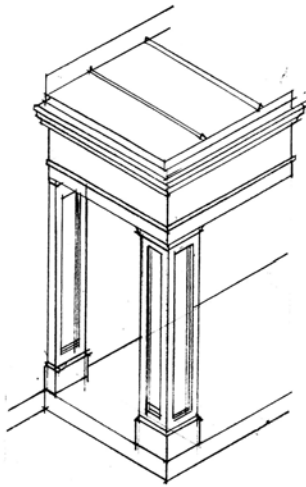

Georgian

Wood columns, round or square classical design.

Columns may be plain or fluted.

Flat metal roof or front-facing pediment.

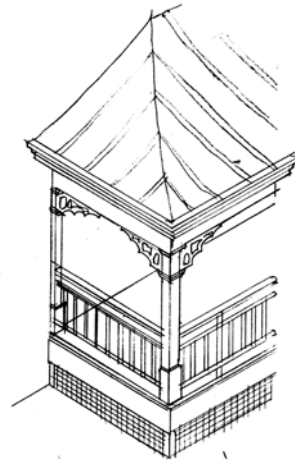

Victorian Gothic

Wood columns, often turned.

Ornate "gingerbread" brackets.

Often with metal roof, often "bell-cast" shape.

Balusters on railing usually square.

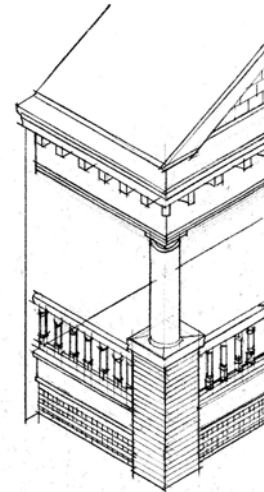

Edwardian Styles

Classical columns on stone-capped brick piers.

Front-facing pediment or hipped shingle roof.

Classical detailing like column capitals and dentils.

Balusters on railing turned or bellied.

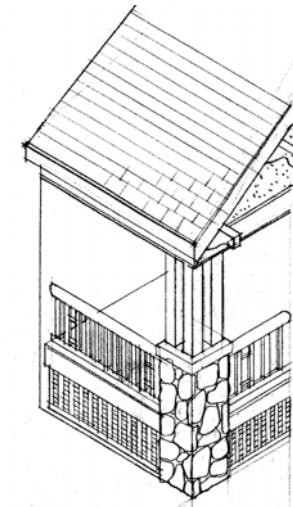

Arts and Crafts

Rustic timber columns, often clustered, often on rubble base.

Sense of exposed carpentry, with exposed joist tails, often cut to form a bracket.

Balusters often installed with thin face outward, often bunched in groups of 2 or 3.

9.2 Heritage Design and Details

9.2.9 Brickwork

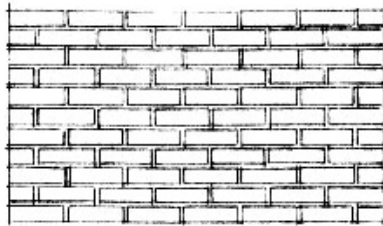

Running Bond

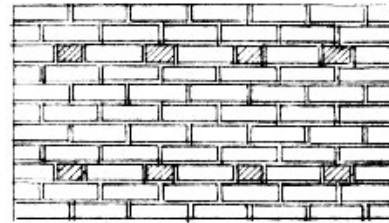

Common Bond

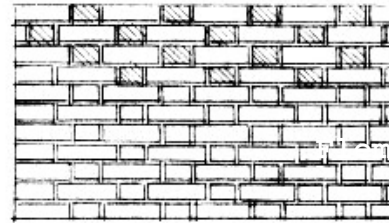

Flemish Bond

Historic brick walls were solid masonry, and in order to carry the weight of floors and roofs they were two or more bricks thick. It was structurally necessary to tie the inner and outer wythes together, and the simplest and surest way to do this was to put headers across the thickness of the wall at some regular interval. The pattern in which the bricks are laid is called the “bond”.

Modern brickwork is usually a veneer in front of a frame or concrete block structural wall. The veneer is typically tied to the structure with metal ties, and there is no structural need for headers. Because it's quick and easy, the running bond, shown at upper left, is commonly used for modern brick veneer walls.

Historic bonds, which use headers, provide a subtle but lively texture to a wall. The cost of laying one of the historic bonds by using half-bricks to replicate the headers is extremely small, and it is a simple way to maintain heritage character in new construction.

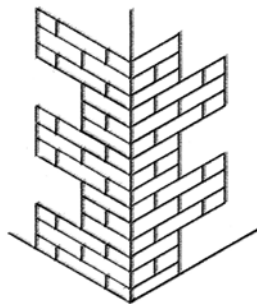

Correct Quoining

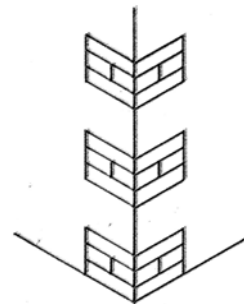

Incorrect Quoining

Brick quoins imitate larger stone quoins, which interlock to strengthen the corner of a building. A quoin block has a short side and a long side, and brick quoins should be laid in the same form, as shown in the sketch on the left. The sketch on the right shows what not to do.

9.2 Heritage Design and Details

9.2.9 Brickwork Cont'd

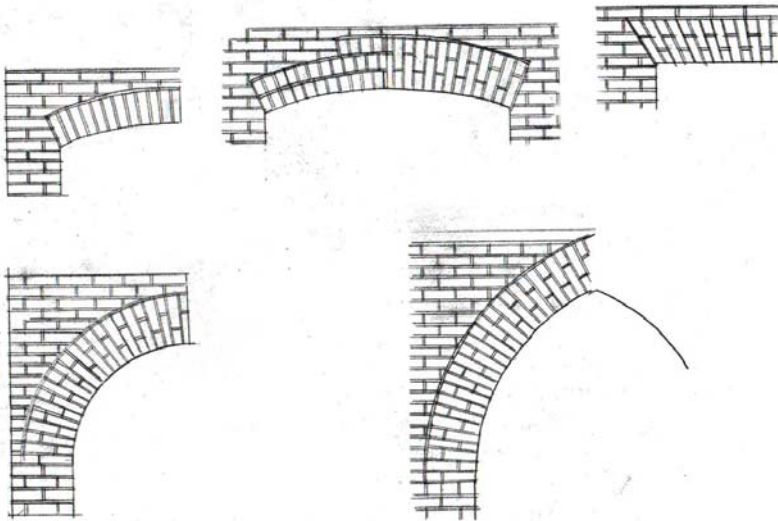

Before the use of iron and steel in construction, lintels over structural openings in brick walls were either solid stone or brick arches. Modern construction commonly uses steel lintels, hidden by the brickwork. To create an authentic appearance, the bricks should be laid to replicate historic structural arches. It is common practice to use a simple soldier course above an opening, without the outward slant that provides arch action in an authentic arch.

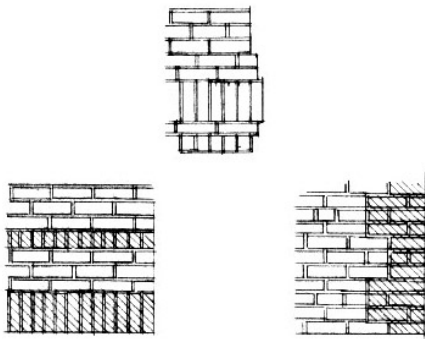

Victorian and Queen Anne Revival brickwork was rich in colour and pattern. Projecting and recessed courses, the use of headers, rowlock, and dogtooth courses, and contrasting quoins were all used to enliven masonry. It's not unusual to find designers limiting themselves to quoins and soldier courses. However, when working in the vocabulary of historic styles, it is more authentic to make use of the full variety of historic brickwork. Some manufacturers provide shaped bricks, which were also part of many historic styles.

9.2 Heritage Design and Details

9.2.10 Wood Siding

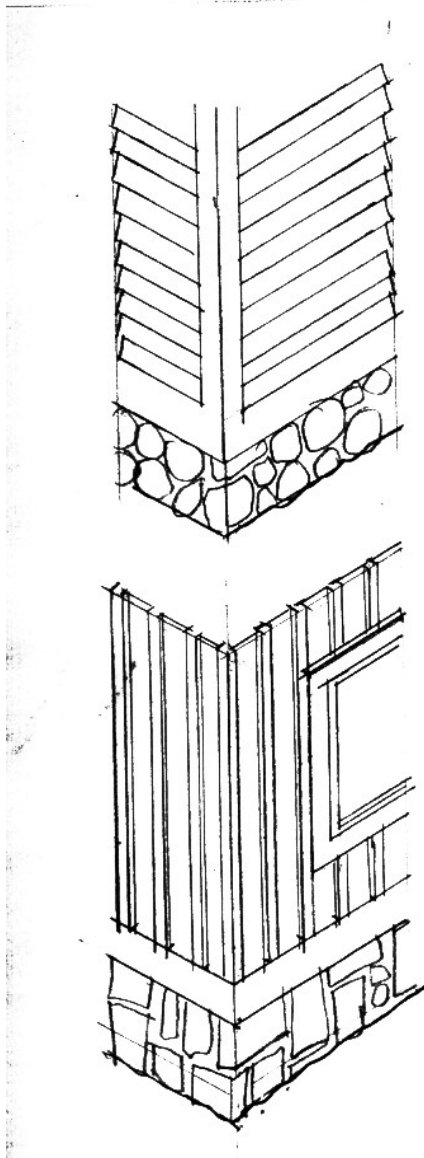

The most typical historic wood siding types were clapboard and board and batten. Clapboard was commonly installed with about 4 inches to the weather.

Board and batten siding was typically about a 10 inch board with a 2 inch batten.

Note the wide skirt board at the bottom of the walls, and the corner boards on the clapboard.

Stone foundations were common in 19th century buildings. The top sketch shows split-faced fieldstone, and the bottom sketch shows dressed fieldstone

9.2 Heritage Design and Details

9.2.11 Fencing

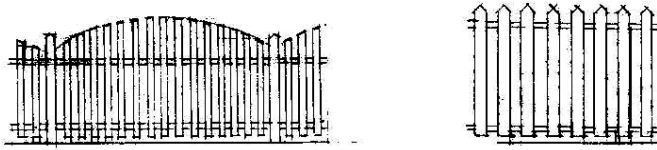

Traditional front-yard fencing is usually fairly low. Historic photographs show a wide variety of fence types in old Maple, including split-rails, horizontal boards and most commonly, wood picket fences.

There is, and was, considerably variety in design. Narrow boards and wide boards; square, pointed, and rounded tops; and railing-type fences with the pickets housed in the top and bottom rails are all in evidence

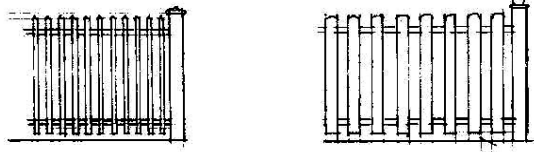

Iron fences appeared on wealthier properties in the late Victorian age, but they don't appear in any of the historic photographs of Maple.

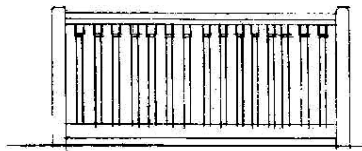

A very substantial picket fence is seen in front of the James Kirby House at 9983 Keele Street. Photo from the Vaughan Archives

9.3 Existing Heritage Buildings

9.3.1 Overview

Maple is fortunate in having numerous historic buildings, most of which are structurally sound, with original architectural details largely intact in many cases. In many cases, details are in need of maintenance or repair, or have been obscured or removed in previous renovations. This section aims to assist in the preservation of historic architecture, and the restoration of lost or concealed heritage character, through design that follows the original or is at least sympathetic to it, when new work is undertaken.

Guidelines:

- The existing heritage structures are the most significant elements of the heritage character of Maple.
- The map to the left shows the buildings that are considered to be heritage properties for the purposes of this Plan. There are 51 properties in the District that are listed in the Vaughan Register of Property of Cultural Heritage Value. The consultants have identified 4 additional properties: 9690, 9706, and 9964 Keele Street, and 9 Hill Street.
- Proper maintenance of heritage structures prevents deterioration, and is the most cost-effective means of preserving heritage character.
- When heritage features are damaged or deteriorated, repair and restoration are preferable to replacement.
- New construction should not damage or conceal heritage features.
- New construction should include restoration of heritage features that have been lost or concealed by previous renovations.

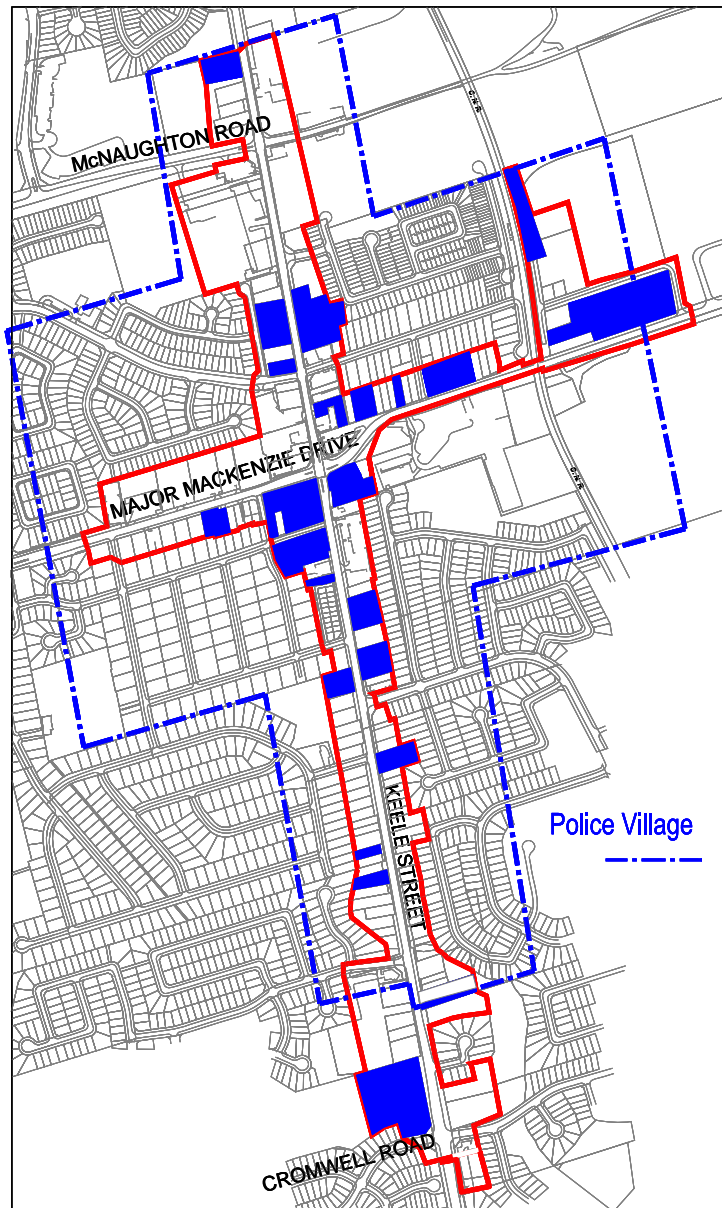

9.3 Existing Heritage Buildings

9.3.2 Historical and Technical Research

The original state of existing heritage buildings should be researched before work is undertaken. On-site investigation often reveals original details concealed under later work. The Vaughan Archives has an extensive collection of historic photographs.

Maintenance, repair, replacement and restoration work should be undertaken using proper heritage methods. Modern materials and methods of construction can have detrimental effects on old construction if proper methods are not used. This is particularly true of old brick. Section 10 lists some books containing relevant technical information.

The United States National Parks Service publishes *Preservation Briefs*, with detailed 'how-to' information on many aspects of heritage preservation and restoration. All 42 of these publications can be downloaded from: www.cr.nps.gov/hps/tps/briefs/presbhom.htm

The Parks Canada Standards and Guidelines for the Conservation of Historic Places in Canada is similar, and is available on line at: www.pc.gc.ca/docs/pc/guide/nldclpc-sqchpc/index_E.asp

The Ontario Ministry of Culture also has 13 *Architectural Conservation Notes* at: www.culture.gov.on.ca/english/culdiv/heritage/connotes

9.3.3 Recording Original Construction

It is important to build up the record of historic construction in the District. No reconstruction or removal of historic architectural detail should be undertaken without recording the original with drawings and/or photographs. Copies of these records should be given to Cultural Services at the City of Vaughan. Building such an archive of information is an important community effort.

9.3 Existing Heritage Buildings

9.3.4 Building Maintenance



The principal enemies of existing heritage buildings are fire and water. Proper maintenance is the best way to prevent damage and deterioration from these causes. **The loss of heritage detail and even entire buildings, due to simple neglect, is an avoidable tragedy.**

Standard fire-prevention practices should be followed: check electrical systems, and don't overload circuits; ensure that heating systems are in good condition; store combustibles properly.

Roofing, flashing, and rainwater drainage should be maintained in good condition. It is far better and cheaper to keep moisture out of the building, than to deal with the damage later.

Structural damage that admits moisture, such as settlement cracks, should be promptly repaired.

Painted woodwork should be maintained.

9.3 Existing Heritage Buildings

9.3.4.1 Masonry Cleaning

Masonry cleaning should be done in a non-destructive manner. Ontario bricks are soft and subject to deterioration by harsh cleaning methods. Good results can usually be obtained with detergents and water and a stiff natural-bristle brush. Some professional water-borne chemical agents are acceptable. Sand-blasting and high-pressure water blasting are unacceptable.

Historical photographs show that most original masonry in Maple was unpainted. Unless paint can be historically documented it should not be applied, and existing paint should be removed. Paint may be applied only where deterioration of the masonry leaves no other choice. Paint must be vapour-permeable (breathing-type) to prevent deterioration. See illustration at right.

Preservation Briefs has full information on proper materials and methods. See Section 9.3.2 for website.

Guidelines:

- Clean masonry using detergents and a stiff natural bristle brush. If this doesn't produce satisfactory cleaning, use only professional water-borne chemical agents for further cleaning.
- Do not use sand-blasting or high pressure-water for masonry cleaning.
- Do not paint historic masonry unless deterioration of masonry leaves no other choice.
- If masonry must be painted, use an appropriate breathing-type paint.
- Do not cover historic masonry with other materials such as stucco.



Non-breathing paint on brick. The vapour pressure of moisture in the brick blisters the paint, when it is able. If the paint adheres strongly, the pressure causes the brick surface to spall off, along with the paint, as seen in the centre of the picture. This lets in even more moisture, and the problem grows.

9.3 Existing Heritage Buildings

9.3.4.2 Masonry Repointing

Historic lime mortars weather back from the wall face over time, particularly when they are subject to moisture. This is normal, and repointing is only necessary when the mortar is deeply eroded. Repointing should only be undertaken in areas where the mortar has deteriorated. Don't remove sound mortar unnecessarily, but do poke and prod to make sure the mortar you are keeping is sound. If the pointing mortar is correctly formulated, and the joint is tooled to match the original, the repointing will not present a "patchy" appearance.

Historic lime mortar is softer and more water-permeable than modern portland cement mortars, and it preserves the brick by absorbing movements and providing a path for water to leave the wall. Modern Portland cement mortars, are designed for modern hard-fired bricks, and are highly destructive to softer historic bricks. The colour of historic mortars comes primarily from the colour of the sand in the mix, so care is required to establish a matching appearance.

Guidelines:

- Repair structural damage before repointing. Structural cracks may be letting in the moisture that is eroding the mortar.
- Do not use power tools to remove old mortar. They can damage the weather-resistant skin of the brick and cause future deterioration of the wall.
- Use lime mortar for repairs and repointing of historic brick. Match the original in formulation, with a cement content no greater than one-twelfth of the dry volume of the mix; the cement must be white portland cement and not grey.
- Do not treat historic brick with silicones or consolidants. They trap water vapour behind the surface of the brick which may damage the face by freezing or leaching of salts.



Progressive deterioration: Rainwater splashing on the porch and steps eroded the mortar. That let increasing amounts of water into the bricks and mortar below, and they are spalling and washing away, letting in even more moisture.

9.3 Existing Heritage Buildings

9.3.4.3 Painting Woodwork



Properly maintained and protected woodwork is a very durable building material. Deterioration of wood is almost always due to moisture problems: either a failure of the paint film or a problem, such as a flashing or roofing failure, that allows moisture to infiltrate from above and behind the finish surface. Blistering or peeling paint is usually a sign of moisture penetration. The source of the moisture should be identified and corrected before repainting. Refer to Section 9.3.4.5, below, if repairs are necessary before repainting.

Normally, it isn't necessary to remove sound, well-bonded paint before repainting. Paint removal, when required, is best done using gentle traditional methods. Chemical strippers can impregnate wood and harm the bonding ability of new paint, and excessive heat can cause scorching damage.

Guidelines:

- Inspect existing paint. Blisters or peeling paint usually mean water is getting into the wood, and the source of water should be corrected.
- Don't "strip" woodwork, unless paint build-up is excessive and obscures architectural detail. Just remove loose paint and feather edges.
- Don't use chemical strippers or torches to remove paint. These damage the wood and cause future problems.
- Use suitable heritage paint colours. Original paint colours can usually be found by sanding or scraping through overpainted layers. Otherwise, approved heritage palettes are available at Cultural Services.
- Both *Preservation Briefs* and *Architectural Conservation Notes* have information on painting. See Section 9.3.2. for websites.



9.3 Existing Heritage Buildings

9.3.5 Repair and Restoration

Repair and restoration should be based on proper heritage research, and be undertaken using proper heritage materials and methods. Section 10 lists helpful sources of information.

9.3.5.1 Brickwork

Brick repair should be undertaken using proper heritage materials and methods. If available, salvaged bricks matching the original should be used for replacement material. If new bricks are necessary, they should match the original in size, colour, and finish. The traditional Ontario brick size is still manufactured, but in small quantities, so material may have to be ordered well in advance of the work.

Historic bricks require the use of historic lime mortar. See the notes and guidelines in Section 9.3.3.3, under masonry repointing.

Guidelines:

- Repair structural damage before restoration.
- Use matching bricks for repairs, either salvaged old material or the best modern match in size and colour.

9.3.5.2 Stonework

Spalled stone can be restored using professional epoxy-based fillers matching the underlying stone. More serious deterioration will require replacement by new material, matching the existing. Use of precast concrete to replace stone is discouraged.

9.3 Existing Heritage Buildings

9.3.5.3 Roofing

Heritage buildings might have originally had wood shingles, slates, or sheet metal roofing. Very few of the original roofs remain, and the asphalt shingle is the dominant roofing material in Maple today. In re-roofing heritage buildings, care should be taken to choose a material that relates to the original roofing. If asphalt shingles are selected, colours should be black or a dark grey, like slate or weathered cedar. The use of textured premium grades improves the simulation, and synthetic slates and panelized synthetic cedar shingles can present a very realistic appearance. Note that roofing tiles are not part of the local vernacular, and tile or simulated tile (of concrete or pressed steel) are not appropriate.

9.3.5.4 Wood Frame Construction

The earliest buildings were of log construction but were quickly supplanted by wood frame construction. Over history, original siding materials would have included wood clapboard, board and batten, and more rarely, stucco. Agricultural buildings used vertical boards. The heritage quality of many old buildings has suffered by the application of aluminium or other modern sidings. Renovations to wood frame heritage construction should include restoration of original siding materials when they have been covered by these inappropriate materials.

9.3.5.5 Decorative Woodwork

Deteriorated woodwork should be repaired, if possible, rather than replaced. Repairs should use the same wood species and design as the original. If replacement is necessary, it should conform to the original design, and wood should normally be used, rather than modern materials. Well-maintained and properly detailed woodwork is quite durable: much of the existing heritage decoration in Maple has lasted more than a century. In certain situations, with extreme exposure to weathering, modern materials may be considered acceptable substitutes.



With occasional maintenance, the wood “gingerbread” trim and windows have lasted about 130 years.

9.3 Existing Heritage Buildings

9.5.4..6 Windows Repair and Restoration

Original window frames and sashes should be repaired if possible, rather than replaced. Repairs should be limited to damaged portions of the window assembly. This is not only good heritage practice: it is usually less costly. Repair material should be of the same species and profile as the originals.

Historic wood windows perform very well in terms of life-cycle costing, and can have very good energy efficiency as well. It is worth considering these factors before deciding to replace original windows. Many historic windows have lasted for more than a century, with only minor routine maintenance, such as puttying, painting, and the occasional adjustment of fit and hardware. It is unlikely that any modern replacements would venture to guarantee similar longevity.

Energy costs need to be considered as a whole, not simply comparing the R-values of the glazing. Heritage buildings have a relatively small percentage of openings compared with more modern designs. Even an ordinary wall outperforms the best glazing by a large margin.

In addition, the energy performance of a window assembly is more dependent on air leakage than on the insulative qualities of the glass itself. It is fairly easy and inexpensive to improve the fit and add weatherstripping to historic windows, so that air infiltration matches modern standards. The addition of interior or exterior storm windows gives further energy savings, and eliminates or reduces the biggest problem of single glazing, which is cold-weather condensation.

A recent speech by Donovan D. Rypkema, the foremost expert in the economics of preservation, noted that:

Properly repaired historic windows have an R factor nearly indistinguishable from new, so-called “weatherized” windows.

Regardless of the manufacturers’ “lifetime warranties,” 30 percent of the windows being replaced each year are less than 10 years old.

One Indiana study showed that the payback period through energy savings by replacing historic wood windows is 400 years.¹

A full discussion of energy considerations in historic buildings is available in Preservation Briefs No. 3. See Section 9.3.2 for the website.



Life-cycle costing makes wood look good. The District has many wood windows that are still in service after more than a century.

“No maintenance” materials can’t be maintained, and need replacement when they fade, chip and dent.

¹ Speech to the Annual Conference of the National Trust for Historic Preservation. Portland, Oregon, October 1, 2005.

9.3 Existing Heritage Buildings

9.3.5.6 Windows Replacement Windows

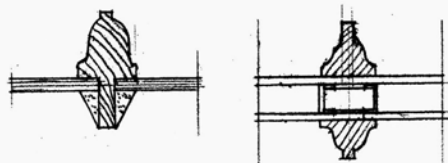

The proportions of original glazing bars can be matched for double-glazed windows with bonded muntins with internal spacer bars.

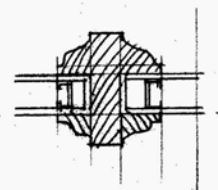

Most double glazed “true” lights require glazing bars that are much wider than the originals.

If original windows cannot be repaired or restored, replacement windows are an option. If possible, replace only damaged portions; for example, replace the sash but retain the frame. Window design should match the original in type, glazing pattern, and detail. In many buildings, windows have been replaced, and it may require some research to determine the original design. The descriptions in Section 9.2.3 may be useful, or original windows in similar neighbouring buildings might offer a clue.

In recent years window manufacturers have responded to the market for authentic heritage windows. Catalogues now include round- and segmental-arch heads and a variety of glazing patterns, providing good representations of most historic styles.

Some care needs to be taken in detailing. Two common problems are heavy glazing bars, and horizontal orientation of the panes in multi-light sash.

True muntins for double-glazed windows are too heavy to preserve the proportions of original windows. Bonded muntins inside and out, with spacer bars in the air space, provide better proportions for an authentic appearance in most residential-scale windows.

Care is also needed in the proportions of the “panes”, which should have a greater height than width. Depending on the manufacturer, and the size and type of window, the manufactured muntin grilles may not have correct proportions.

“Snap-in” interior muntins or tape simulations are not acceptable.

Casement windows that mimic single-hung windows are also not acceptable.

9.3 Existing Heritage Buildings

9.3.6 Renovations

When a renovation on a heritage building is undertaken later work that conceals the original design or is unsympathetic to it should be removed.

Guidelines:

Incorporate restoration of original work in exterior renovation projects.

- Use authentic original materials and methods. For example, when replacing aluminum siding, use wood siding or board and batten.
- Replace missing or broken elements, such as gingerbread, spindles, or door and window trims.
- Remove items, such as metal fascia and soffits that conceal original architectural detail.

9.3 Existing Heritage Buildings

9.3.7 New Additions to Heritage Buildings

Architectural Style

New attached additions to heritage buildings should be designed to complement the design of the original building.

Guidelines:

- Design additions to maintain the original architectural style of the building. See Section 9.1.
- Use authentic detail. See Section 9.2.
- Research the architectural style of the original building. See Section 10 for useful research sources.
- Follow the relevant guidelines for new construction in Section 9.5.



These additions follow the Georgian precedent of the original building.

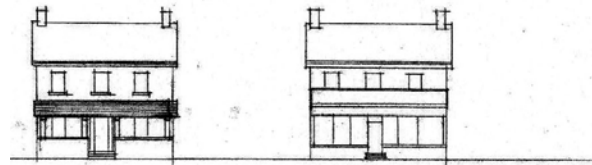
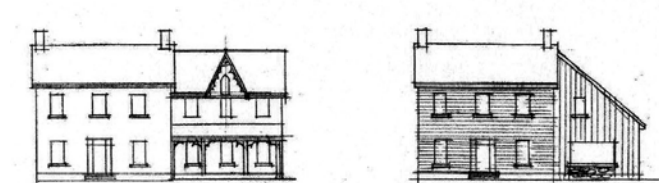

These additions use styles that don't match the original.

9.3 Existing Heritage Buildings

9.3.7 New Additions to Heritage Buildings Scale

New additions to heritage buildings should respect the scale of the original building.

Guidelines:

- Don't design additions to a greater height or scale than the original building.
- Don't design additions to predominate over the original building.

Usually, additions should be located at the rear of the original building or, if located to the side, be set back from the street frontage of the original building.

- For garage additions, see Section 9.3.8
- Use appropriate materials. See Section 9.8.
- Avoid destruction of existing mature trees. See Section 9.7.

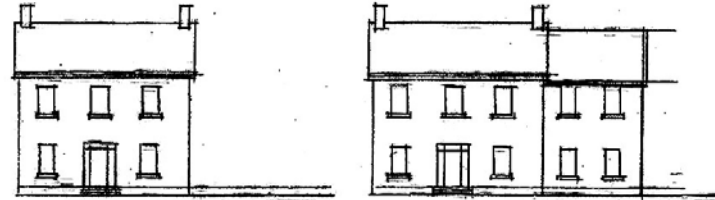

In keeping with good heritage practice, these additions are of lesser scale than the original house and are set back from the main front wall.

9.3 Existing Heritage Buildings

9.3.8 Outbuildings for Heritage Buildings.

Traditionally, garages or stables were built as separate rear outbuildings with gable roofs.

Guidelines:

- Work on existing heritage outbuildings should retain or restore original design features.
- New garages should respect traditional siting as separate rear outbuildings, if possible.
- Connected garages should minimize their street presence. For example, a garage may be turned so that the doors face a side lot line, or it may be set well back from the main frontage, with the connection to the main building disguised or hidden.
- Design garages to traditional outbuilding forms, with gable roofs, and frame or brick construction.
- Use single-bay garage doors, compatible with traditional designs. Suitably designed overhead doors are now widely available.
- Other outbuildings, such as garden and storage sheds, should be of traditional wood construction when visible from the street. Prefabricated metal sheds, if used, should be located to be out of view from the street.

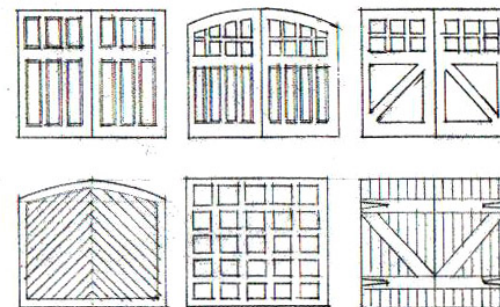

Garages should be designed with single bays, and doors should reflect historic designs. There are now a wide range of heritage-compatible doors available from many manufacturers.

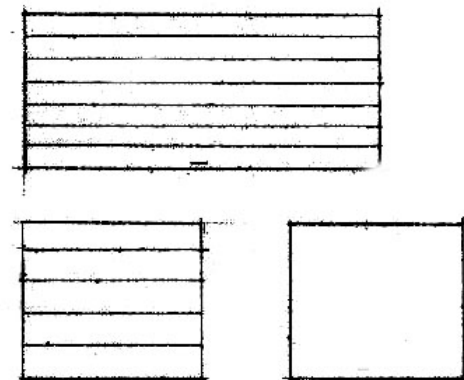

Double-bay garage doors and flat slab-type garage doors are not appropriate in the District

9.4 Existing Non-Heritage Buildings

9.4 Existing Non-Heritage Buildings

Most of the buildings in the Village are not considered heritage structures. Many of these, by virtue of their scale, siting, and surrounding landscaping, nevertheless contribute to the overall character of the area. Buildings deserve some respect on their own terms, and it is not the intent of the Guidelines to ask newer buildings to pretend to be anything other than what they are.

9.4.1 Design Approaches

Additions and alterations to non-heritage buildings have an impact on their heritage neighbours and the overall streetscape. There are two design approaches that are appropriate to additions and alterations to such work in the Village.

9.4.1.1 Contemporary Alteration Approach

Ordinarily, a modern building should be altered in a way that respects and complements its original design. Interest in preservation of the modern architectural heritage is growing, and good modern design deserves the same respect as good design of the 19th century.

Guidelines:

- Additions and alterations using the Contemporary Alteration approach should respect, and be consistent with, the original design of the building.
- The Guidelines in Section 9.3.6 for additions to heritage buildings apply, in terms of siting, scale and location of additions.
- Many modern buildings are old enough to have already undergone renovations, which may not be in character with either the original design, or historic precedent. In such cases, the design of further new work should restore the architectural consistency of the whole.
- In some cases, modern buildings predominantly feature materials that are out of keeping with the local vernacular heritage, such as tile or artificial stone veneer, and tile or simulated tile roofing. Replacement of these materials with more sympathetic ones, when renovations are being undertaken, is encouraged.

A typical 1970s ranch bungalow.

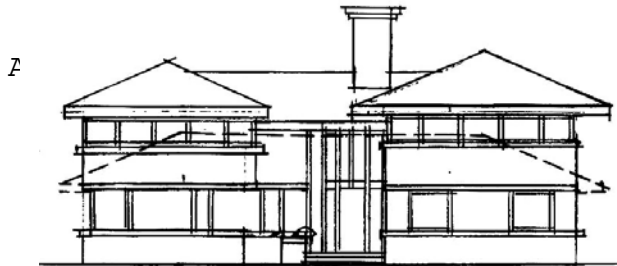
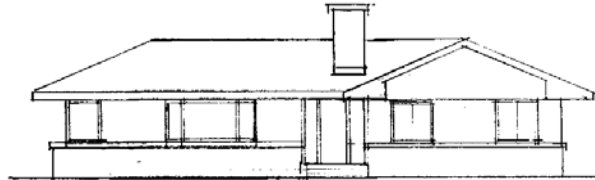

The Contemporary Alteration approach used in putting on a second storey addition.

9.4 Existing Non-Heritage Buildings

9.4.1.2 Historical Conversion Approach

In some cases, a modern building may be altered in a way that gives it the appearance of an older building. A historical conversion should have the integrity of an historical architectural style. This approach means considerably more than sticking on a few pieces of historical decoration; it may require considerable new construction to achieve an appropriate appearance.

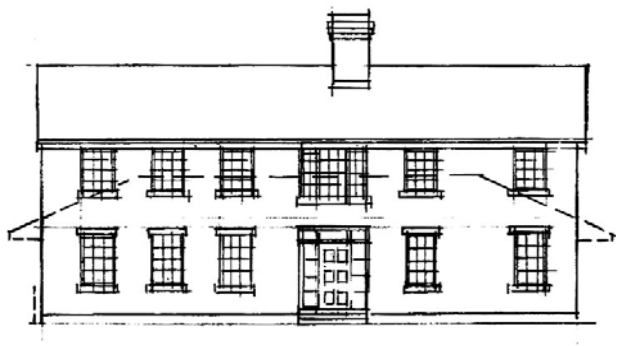

The Historical Conversion approach used in putting a second storey addition on the same house. above.

Guidelines:

- Additions and alterations using the Historical Conversion approach should rely on a local heritage style described and depicted in Section 9.1. Use of a style should be consistent in materials, scale, detail, and ornament. Refer to new construction guidelines in Section 9.5 for further guidance.
- Although most additions should be modest in comparison to the original building, the Historical Conversion approach may call for substantial additions in front of and on top of the existing building.
- Additions should avoid destruction of existing mature trees. See Section 9.7.

9.5 New Development

9.5 New Development

9.5.1 Overview

The overall heritage character of the District is composed of buildings, streetscapes, landscapes, and vistas. This overall character has more significance than any individual building, even if it is one of the finest. Within the design of any individual building, architectural elements contribute to the character of the public realm of the street. Massing, materials, scale, proportions, rhythm, composition, texture, and siting all contribute to the perception of whether or not a building fits its context. Different settings within the district have different characters of siting, landscaping and streetscaping.

New development within the District should conform to qualities established by neighbouring heritage buildings, and the overall character of the setting. Designs should reflect a suitable local heritage precedent style. Research should be conducted so that the style chosen is executed properly, with suitable proportions, decoration, and detail.

Guidelines:

- New buildings should reflect a suitable local heritage style. Use of a style should be consistent in materials, scale, detail, and ornament.
- Use Section 9.1 for preliminary guidance on styles.
- Use Section 9.2 gives further preliminary guidance on details of design and construction.
- It is highly recommended that owners engage design professionals skilled in heritage work for new buildings in the District.

9.5 New Development



9.5.2 Residential Area Overview

The residential village has a variety of lot sizes, frontages, and setbacks. Houses are mostly of a modest scale, leaving generous yards on all sides. In the historic area front yards tend to be shallow compared to the rear yards, where space was needed for stabling, herb and vegetable gardens, and orchards. An early village household needed these means for self-sufficiency, and lawns and decorative planting were minimal. The use of the yards has changed, and they provide more pleasure and less production now, but to a great extent the original village scale has persisted. Building height, lot coverage, and density are all low. The streetscapes are unified by a canopy of trees, planted in front of, behind, and beside most houses. Elements that define the heritage character of the residential village include:

- Generous lot sizes and modest house sizes, compared to historic urban development or recent suburban development;
- A variety of front-yard setbacks;
- The generous presence of mature trees, in addition to decorative shrubbery, in the front, side, and rear yards.

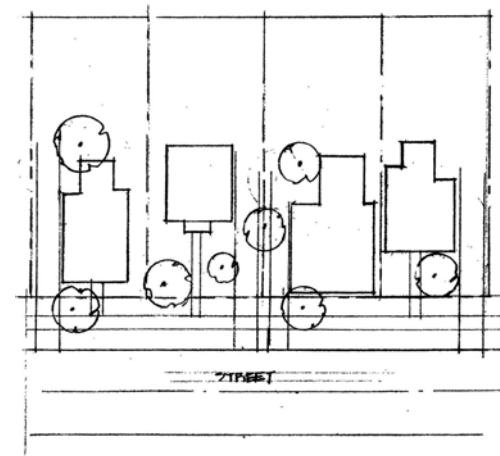

Buildings and trees share in forming the streetscape.

9.5 New Development

9.5.2 Residential Village

9.5.2.1 Site Planning

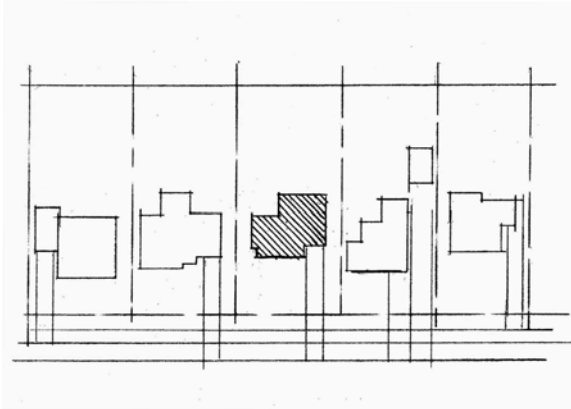

Respect the existing site plan character of similar, but not identical front-yard setbacks. Place a new building to mediate between setbacks of neighbouring buildings.

Guidelines:

- Site new houses to provide setbacks and frontages that are consistent with the variety of the village pattern.
- Site new houses to preserve existing mature trees. See Section 9.7.

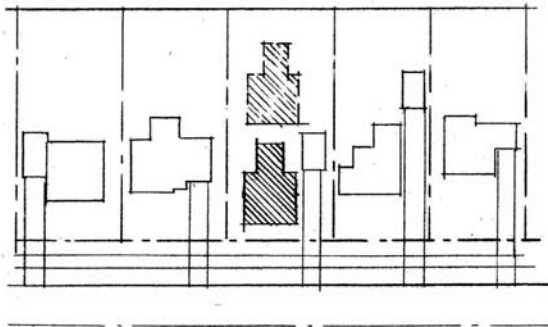

An extreme difference in setback from adjacent buildings is not appropriate.

9.5 New Development

9.5.2 Residential Area 9.5.2.2 Architectural Style



New buildings in the residential areas should reflect the historic built form of their historic neighbours.

Guidelines:

It's possible to build new houses that are highly compatible with heritage buildings. These recent houses were built in the Unionville Heritage Conservation District.



- Design houses to reflect one of the local heritage Architectural Styles. See Section 9.1.
- Hybrid designs that mix elements from different historical styles are not appropriate. Historical styles that are not indigenous to the area, such as Tudor or French Manor, are not appropriate.
- Use authentic detail, consistent with the Architectural Style. See Section 9.2.1.
- Research the chosen Architectural Style. See Section 10 for useful research sources.
- Use appropriate materials. See Section 9.8.

9.5 New Development

9.5.2 Residential Area

9.5.2.3 Scale and Massing



Design new houses to be consistent with the scale of neighbouring ones.



Don't design new houses that are inconsistent with the existing neighbourhood scale.

New residential construction in the residential villages should respect local heritage precedents in scale and massing. In almost every case, new construction will be replacement houses on existing built lots. Note: It is recommended in Section 7 that the zoning by-law be amended to recognize the smaller scale of historic village development as contrasted with modern suburban development.

Guidelines:

- New buildings should be designed to preserve the scale and pattern of the historic District.
- New houses should be no higher than the highest building on the same block, and no lower than the lowest building on the same block.
- As far as possible, modern requirements for larger houses should be accommodated without great increases in building frontage. For example, an existing 1½-storey house could be replaced by a 2-storey house with a plan that included an extension to the rear. This might double the floor area without affecting the scale of the streetscape.
- Follow the policies in Section 4.4 of this Plan concerning height and depth of buildings and garages.
- For garages, see Section 9.3.8.

9.5 New Development

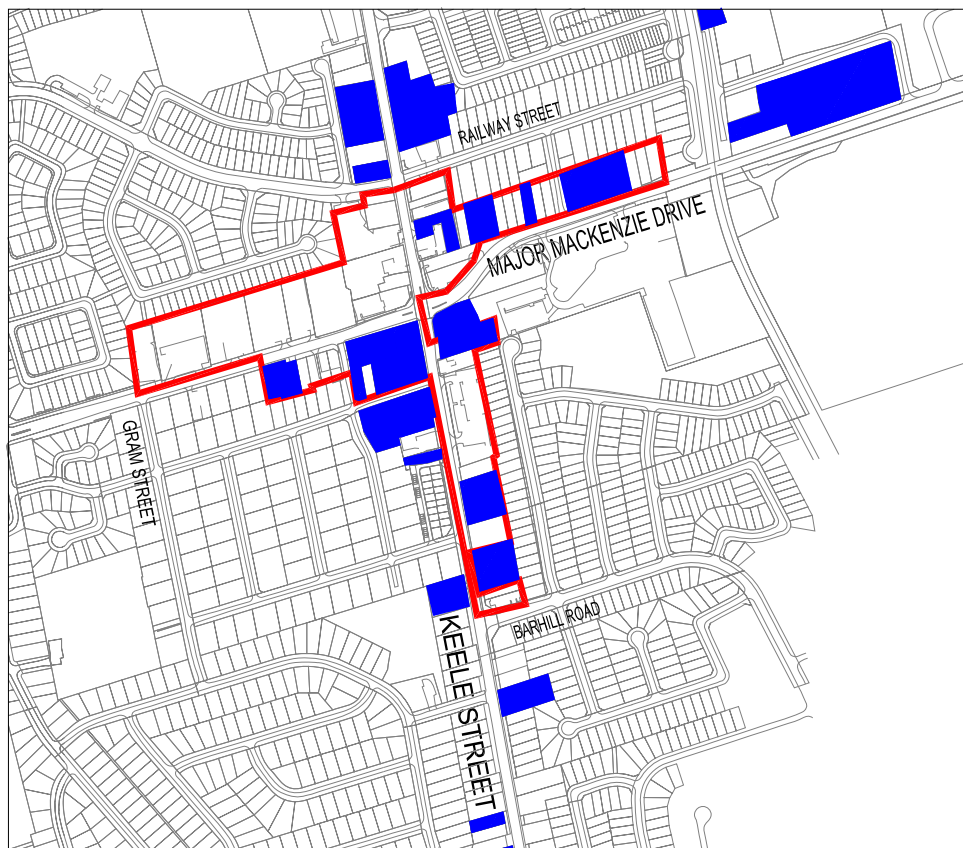

The Maple Commercial Core is defined by OPA 350 with the boundary as shown above. The shaded properties are heritage properties.

9.5.3 Commercial Core

9.5.3.1 Character

- The Maple Commercial Core, as defined by OPA 350, is larger than the historical commercial area which was more compact, and very close to the crossroads.
- The Maple Commercial Core includes 34 heritage properties.
- Except for the Lawrie Store on the southwest corner of Keele and Major Mackenzie, all of the heritage buildings were originally constructed as dwellings. Some have been converted to commercial use, but most remain dwellings.
- In the areas where the dwelling-form buildings predominate, the village pattern has persisted: lots are wide, and trees are a significant aspect of the streetscape.
- There are a number of newer commercial buildings. Some are large-footprint one- or two-storey plazas. In the 20-year horizon of this plan, these sites should be considered as having potential for intensification.
- Heavy traffic, on both Keele Street and Major Mackenzie Drive, is detrimental to pedestrian comfort, particularly where the sidewalk is close to the curb.
- For more detailed descriptions of the character of the streetscapes, see Appendix B.

9.5 New Development

9.5.3 Commercial Core

9.5.3.2 Objectives for guidelines for new development



A view south on Keele Street. Richmond Street intersects on the left just past the first building. Most of the shops are front-gable buildings in the traditional village commercial style.



The same intersection viewed from the south. The camera would be in front of Beaverbrook House. Both photos from the Vaughan Archives.

Overall Objectives

- Preserve existing heritage buildings.
- Ensure that new development respects and enhances existing heritage character and resources.
- Respect the historic residential areas.
- Develop a pedestrian-friendly commercial environment.
- The policies and guidelines for new development in the Commercial Core are suitable for all commercial sites within the district.

Building/Street Relationship

In order to create a commercially viable pedestrian environment, it should be the aim of new development to enhance the sense of security for pedestrians.

Guidelines:

- The use of on-street parking, grassed boulevards, cooperative connected parking arrangements and access, and connected pathways and open spaces between and at the rear of buildings are all supported in site planning of new developments. See site planning guidelines below.
- Entrances shall face the principal street. Corner entrances are encouraged for corner lots. Principal entrances will be flush with the sidewalk, and will comply with the Ontario Building Code and the Ontarians with Disabilities Act in their design.

9.5 New Development

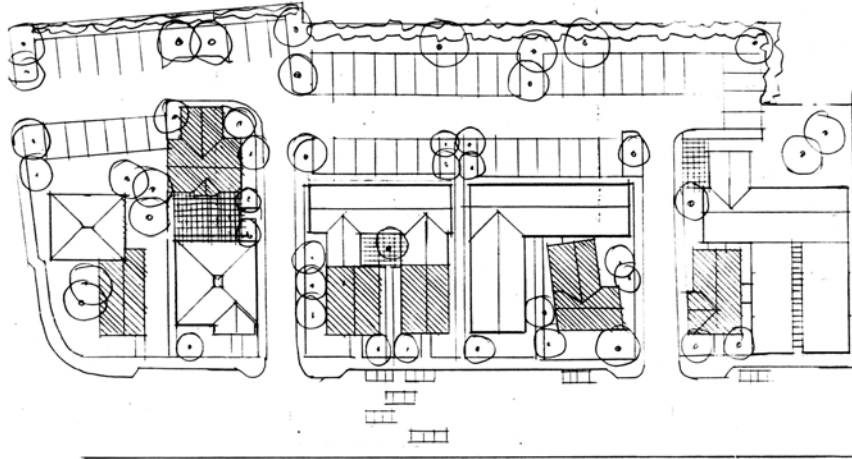

Preservation of heritage buildings, preservation of trees, complementary infill, connected parking to reduce the number of driveways, and parking lay-bys on the street are all elements that contribute to a pedestrian-friendly environment.

9.5.3 Commercial Core

9.5.3.3 Pedestrian Amenity

- The primary obstacle to the creation of a pedestrian-friendly village is the sense of insecurity produced by the fast and heavy traffic on Keele Street and Major Mackenzie Drive.
- The village form, with its front yards and varied setbacks, provides the opportunity for pedestrian-oriented spaces, away from the busy street. These spaces are vital elements in the creation of a pedestrian-friendly environment.
- On-street parking is a valuable traffic-calming measure, and its effect as a pedestrian amenity is even more significant. The sense of protection afforded by a row of parked cars is considerable, particularly where pedestrian space between buildings and curbs is limited. Many municipalities provide on street parking during off-peak hours, even on major arterial roads. It doesn't seem unreasonable to add Maple to the list.
- If on-street parking within the current right of way is denied by the Region, new development should be set back about 3m to allow space for lay-by parking to achieve the same sense of pedestrian protection.

9.5 New Development

9.5.3 Commercial Core

9.5.3.4 Site Plan Characteristics

The site plan characteristics of a village are different than those of a town.

The principal qualities found in a village are:

- The existence of sideyards, even on most commercial properties;
- A variety of frontyard setbacks, with purpose-built commercial buildings tending to be located at the streetline, and residential front yards ranging considerably in depth;
- The use of low fencing or planting to delineate all but the shallowest of residential front yards;
- The random presence of trees in front, side, and rear yards, providing a frame of clumps of greenery to the built form. This is in contrast to the commercial form of towns and cities, where trees are either absent, or arranged as linear boulevard planting.

New developments should be designed to respect and mimic the traditional village form.



Markham, above, grew into a town. There is a fairly continuous line of buildings, constructed on the street line. Kleinburg, below, remained a village. The buildings are separated and front-yard setbacks vary. Trees provide a frame for the buildings, growing in front of, beside, and behind them.



9.5 New Development

9.5.3 Commercial Core 9.5.3.5 Site Plan Guidelines

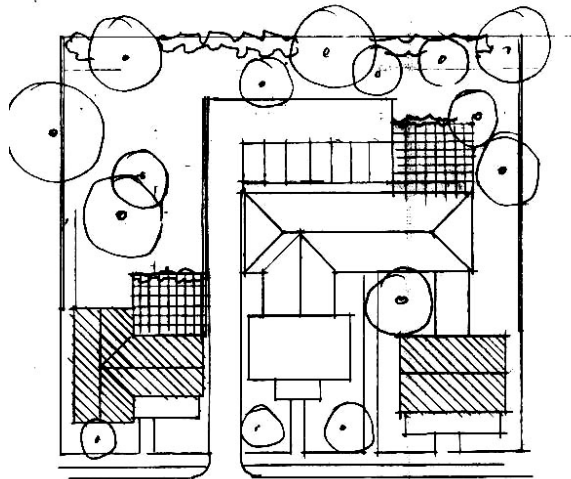

Infill developments should preserve existing heritage structures and existing mature trees. Set-backs should be varied, in keeping with the historic village character.

The example shown above maintains a planted buffer strip at the rear, where it abuts residential properties.

Sites with Heritage Buildings:

Most of the street frontage in the Commercial Core is rich in existing heritage buildings. Intensification should respect the existing heritage character of the streetscape.

Guidelines:

- All existing heritage buildings should be conserved.
- The Zoning By-law for Maple should be revised to ensure that developments which include or abut existing heritage buildings respect, give prominence to, and not overwhelm the heritage buildings. Consideration should be given to the use of angular planes, related to the heritage building height, for adjacent new construction.
- Existing mature trees should be preserved, and new tree planting should be designed to reflect the traditional village pattern. Trees should be planted in front of and beside new buildings and, where possible, behind them. Even when planted in an island in a parking area, these trees will contribute to the village character.
- Variety in front-yard setbacks should be employed. This is in keeping with the character of a village, and also provides areas with a sense of refuge from the busy street.
- Developments with substantial frontages should be designed to provide a variety of setbacks, at the village scale, on the site.
- Front-yard areas created by building setbacks should be planted and/or fenced to the greatest extent allowed by reasonable access to the businesses. A predominance of paving in front-yard areas is not in keeping with the village character.
- Where front-yard patios are installed, they should take the character of a fenced front yard, not a suburban deck with a railing; in-ground planting should be used to soften the landscape in such patios.
- Trees should be native species. See Section 9.7.

9.5 New Development

9.5.3 Commercial Core

9.5.3.5 Site Plan Guidelines Cont'd

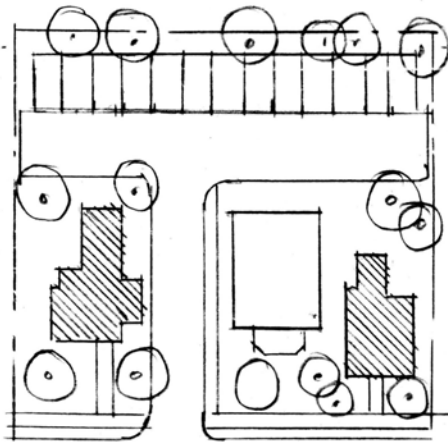

Preservation of the setting is one of the basic principles of conservation.

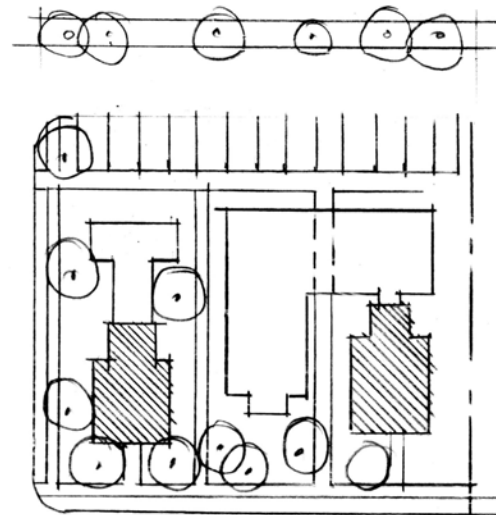

Scale of frontage matches heritage buildings. Rear part of new building could be higher if designed not to overwhelm heritage buildings.

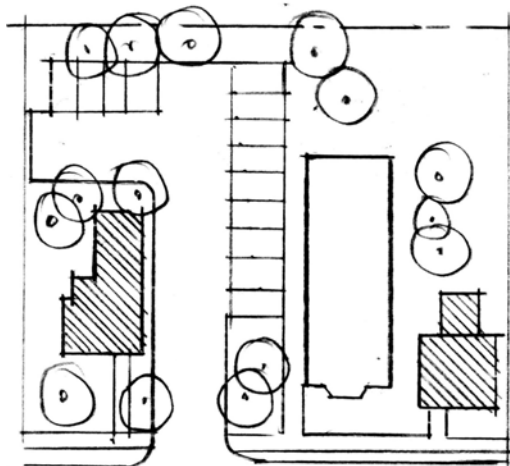

A compromise solution that preserves scale of street frontage and the spatial variety of a village plan.

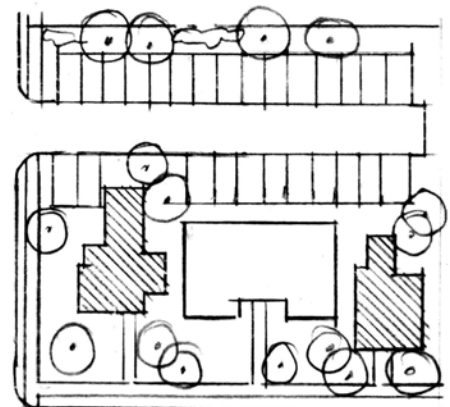

A wider building, but with smaller elements in scale with heritage buildings. Setbacks respect the variety found in the neighbouring lots.

Sites with Heritage Buildings:

Possible site plans for a variety of contexts are shown on the left.

- Site plans respect the varied setbacks typical of a village and respect the existing heritage buildings.
- New buildings are separate from heritage buildings, or the connections are set well back from the frontage.
- Wide elevations are broken up to reflect the scale of width of the heritage buildings.
- Set backs create pedestrian comfort zones away from traffic.
- Planting and fencing are in keeping with the character of historic villages. Trees are planted in front, beside, and behind buildings.

9.5 New Development

9.5.3 Street Commercial Core 9.5.3.5 Site Plan Guidelines Cont'd

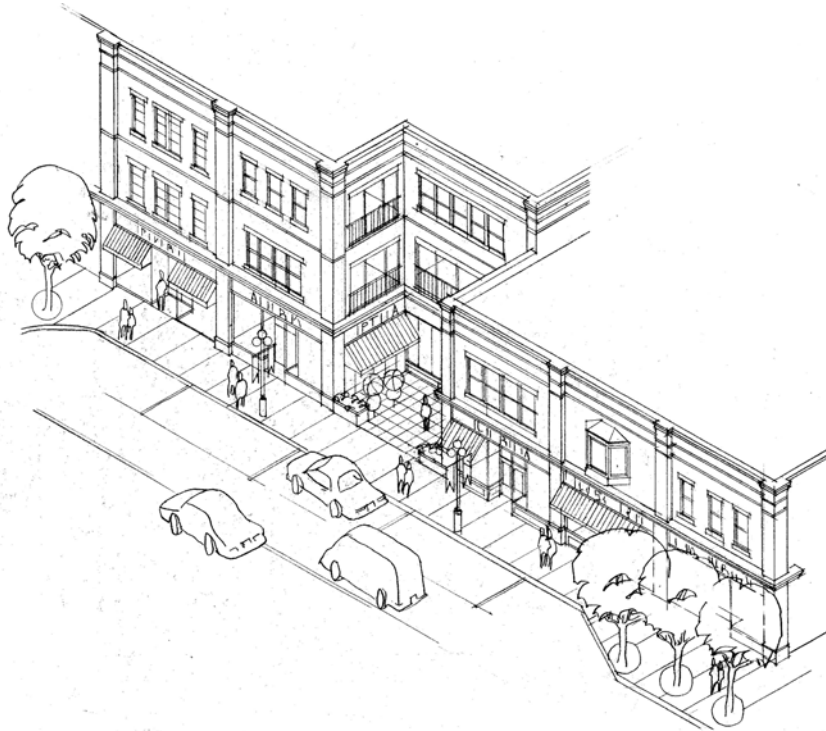

New development based on town commercial buildings. The scale of the building is broken into elements 20 metres wide, and the linking element is set back to create a zone of enhanced pedestrian comfort. A parking lay-by also enhances the sense of pedestrian security, and boulevard trees soften the environment

Large sites without heritage buildings:

On larger sites, without existing heritage buildings, intensification will mean larger redevelopment projects. It is important that these projects respect the overall character of the village, and that their rhythm and scale are integrated with the smaller scale of the historic village.

Guidelines:

- Frontages of designs based on larger heritage precedents, such as town commercial buildings and hotels, should be broken into elements of no more than 20 metres in width.
- Linking elements between such frontages should be set back to provide an area of pedestrian refuge, as a landscaped element, patio, or seating area.
- Landscaping should be provided, including planters, benches and waste receptacles as integral to the design.

9.5 New Development

9.5.3 Commercial Core

9.5.3.6 Scale and Massing



NORTH ELEVATION

These proposal sketches all show projects that respect the scale and height of the existing heritage buildings in Maple.

Scale and massing shall respect the character of the historic Village.

Guidelines:

- Maximum façade height of 3 storeys with a maximum building height of 11.8 metres.
- Height and massing should respect the 1 to 2- storey residential properties when they are adjacent. Mansard roofs are not suitable.
- The ground floor ceiling height should be a minimum of 4.5 metres along all primary commercial frontages.
- A minimum of 75% glazing for retail window display will be pursued for commercial ground floor.
- The height of window and door articulation on the commercial ground floor will respond to the greater ground floor to ceiling height and should appear in proportion with the overall height and massing of the building.
- A high quality of commercial and “store front” design is recommended. Visibility along the commercial ground floor in terms of composition of windows, entryways and materials is encouraged.
- All buildings and commercial units fronting onto a primary or secondary street must have an entrance fronting the primary or secondary street.
- Commercial building entrances should be easily identifiable and appropriately signed.
- The building base occurring along commercial frontage may exhibit a material change from that exhibited along the building mid section above. The use of spandrel glazing on the building will not be permitted.
- Integrated vehicle connections such as arched ground floor passage ways may be suitable.

9.5 New Development



This photograph from Cobourg shows a new building in the foreground, which is modeled on the historic buildings farther along the street.

In Maple, this kind of town-style commercial buildings should be broken up, with a set-back for every third or fourth bay. See the site planning guidelines in Section 9.5.3.5.

9.5.3 Commercial Core

9.5.3.7 Architectural Style

Historic buildings in the Commercial Core consist of a mix of purpose-built commercial structures and house-form residential. Some residential buildings had storefronts added after construction, even at a very early date. Most of the buildings, even purpose-built ones, had gable roofs, although some had “false fronts” to mimic flat roofed town commercial buildings.

New buildings should reflect one of these heritage styles, particularly in its street-front aspect

Guidelines:

- New buildings should reflect a suitable local heritage style. Use of a style should be consistent in materials, scale, detail, and ornament.
- Do not use hybrid designs that mix elements from different historical styles.
- Use authentic materials. In most cases this means brick, with stone sills and brick or stone lintels.
- Use Section 9.1 for preliminary guidance on styles.
- Use Section 9.2 for further preliminary guidance on details of design and construction
- It is highly recommended that owners engage design professionals skilled in heritage work for new buildings in the District.

9.5 New Development

9.5.3 Commercial Core

9.5.3.8 Storefronts

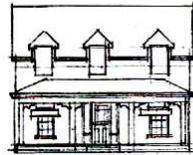

As noted under Architectural Style, above, historic commercial buildings may have been purpose-built or converted from residences. This is typical of a village commercial streetscape, and differentiates it from shopping areas in larger towns and cities. As a result, there is a variety of heritage precedents available for the design of new shopfronts.

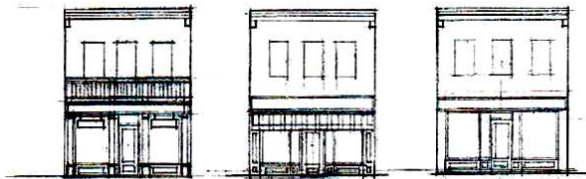

Historical conversions of residential buildings to commercial use often inserted a large window opening, perhaps on only one side of a central door, rather than full width storefront. More recent conversions often leave the original residential window openings in place, if the business doesn't require large display windows.

Guidelines:

- Storefront design should reflect local historic precedents. Design elements within any chosen precedent should be consistently applied.
- Full-width porches are appropriate elements in storefront design.
- Retractable awnings are appropriate. Rigid awnings and fixed canopies are inappropriate.
- Use of traditional wood and glass construction for storefronts is encouraged.
- If modern materials are used, they should be detailed to replicate traditional designs in scale, proportion and architectural effect. For example, the use of wood trim at jambs, posts, and panels can enhance the heritage effect of standard storefront and glazing systems.
- Both *Preservation Briefs* and *Architectural Conservation Notes* have information on heritage storefronts. See Section 9.3.2.

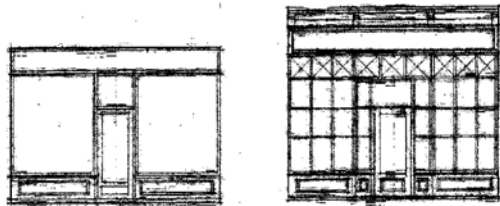

The classic late-19th Century shopfront featured tall glazing, a panelled wood base, and a narrow moulded sign fascia above.

9.5 New Development

9.5.3 Street Commercial Core

9.5.3.9 Signage



Moulded signbands integrated with historic storefronts, small soffit signs above or below porch fascias, and flat externally illuminated wall signs are appropriate in the District.

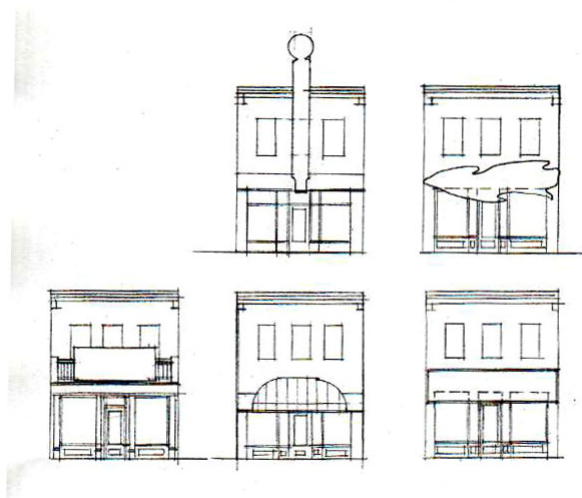

Signs that are modern in form, too large, or that obscure architectural detail are not appropriate in the District.

Guidelines:

The City of Vaughan Sign By-law governs. It will be stringently applied.

- Integrate signage with the design of the storefront, based on historical precedent.
- Back-lit or internally illuminated signs, including awning signs, are not appropriate.
- Neon and readograph signs are not appropriate.
- Third-party signs are not appropriate.
- Awning signs, other than lettering, no more than 6" high, on awning skirts, are not appropriate.
- Ground signs are without heritage precedent and are generally not appropriate. If other sign types would obscure architectural detail on a heritage building, a low ground sign, no higher than 1.0 metre, is acceptable.
- Directory ground signs, listing tenants of a commercial development, are not appropriate.
- Replacement of existing non-conforming signage should be included as part of any work undertaken on properties in the District.

9.6 Streetscape Work

9.6.1 Overview

Work within the road allowance should be designed and executed to meet modern requirements, amenity, and convenience, without detriment to the heritage character of the District. This work is either undertaken by public authorities, as in the case of roadside planting and the construction of roads, curbs, sidewalks, lighting, and road signage or it is subject to approval by public authorities, as in the case of BIA installations, newspaper boxes, and tourism information or identity signage.

District Identity

Installations within the road allowances have a significant effect on the experience of the heritage character of the District and the establishment of a sense of identity. The use of a consistent design vocabulary at the various scales and in the various kinds of road allowance work reinforces the District's identity and supports its economic role as a place of unique historical character in the community. Permits are required for the installation of items such as sidewalks, curbs, paving, street and pedestrian lighting, benches, tree grates, tree guards, trash receptacles, recycling bins, and parking equipment.

Contexts

Maple possesses two distinct contexts: the Commercial Core, and the Residential Areas. The goals of the Guidelines for streetscaping are:

- Enhancing historical character of the road allowances in the Residential Areas.
- Creation of a pedestrian-friendly shopping environment in the Commercial Core.
- Establishing identity through gateways, signage, and markers.

9.6 Streetscape Work



Church Street has a curbless rural profile (above). The grassed and treed boulevard on Keele Street (below) creates a pedestrian friendly environment.



9.6.2 The Residential Streets

Roadways

Church Street, Jackson Street, Hill Street, and Station Street have a curbless rural profile. Other residential areas have grassed boulevards, to a great extent. These are an important part of the heritage character of these streets

Guidelines

- The rural profile should be preserved where it exists.
- Over time, grassed boulevards should be provided where they don't already exist.

Planting

Rural villages are planted informally, with a mix of trees and deciduous shrubs.

Guidelines

- Maintain a village character in street planting. The linear urban planting pattern of regularly spaced boulevard trees is not appropriate here.
- See Section 9.7 for suggested species.

9.6 Streetscape Work

9.6.3 Commercial Core



Creation of a pedestrian-friendly core faces many challenges.

Overview

Creation of a pedestrian-friendly commercial environment is the most important objective of streetscape work in the Commercial Core. Pedestrian amenity is discussed in Section 9.5.3.3, above. Specific improvements, including private and street parking are also discussed under Site Planning, in Sections 9.5.3.4 and 9.5.3.5.

Streetscape installations are an important aspect of meeting the objectives of conserving the heritage character, reducing the impact of traffic on the pedestrian environment, and creating a viable commercial destination.

Early 20th-century photographs of Maple show streetscapes very different from today's. An accurate "historical reproduction" would exclude automobiles, paving, lighting, highway signs, bollards, and benches. It's obvious that a lively commercial area requires all of these things, some of them because they enable and enhance public use and commercial activity in the village core, many of them because regulations and standards govern the design of traffic systems, lighting levels, and so on. There is an inherent historical ambiguity in a Heritage District that must be addressed when evaluating the design of these modern installations. The following principles apply to such an evaluation:

9.6 Streetscape Work

9.6.3 Commercial Core Cont'd

Principles

1. Adapt to the automotive streetscape: As the list of modern artifacts previously detailed shows the automobile and its infrastructure account for much of the visible non-heritage installations in the District. There is a built-in division of the streetscape in its historical aspect: it is inescapably modern from curb to curb. Modern accessories like waste receptacles and street lighting should be placed near to the curb, where they form a transition band between the heritage experience of the buildings and the modern experience of the roadway.

2. Don't accentuate non-heritage installations: Human perception is very good at filtering out unimportant and repetitive information. The modern enthusiasm for heritage has produced a host of "old-fashioned" products. Many of these are poorly executed and overly fussy. As a result, they call undeserved attention to themselves and the attention, thus directed, detects the fraud. Often, a very plain modern item will fade into the recesses of perception and be less intrusive than a deliberately "historical" version.

3. Maintain historical integrity: Even when they don't represent an accurate reconstruction, it is important to choose "historical" items in the context of history. For example, the streetlighting of 1890 can't be reconstructed because there was none. The designer should bear in mind that Maple was a modest hamlet and ask, "If the village HAD installed early lighting, what sort of fixtures would have been chosen?" They would have been simple and functional, and would not have had the ornate qualities of lighting for a big-city promenade.

Applying artificial heritage elements to modern items only calls attention the inauthenticity of the exercise. It's better to choose inobtrusive designs. In the example below, the bus shelter doesn't work, but the waste container does.



Lighting

The future installation of lighting fixtures in the Commercial Core should be selected so as to comply with the principles outlined above. When replacement becomes necessary, due to aging or upgraded standards for light levels and “dark skies”, fixtures of a similar simplicity should be chosen.

Street Furniture

Selection of street furniture should follow the principles outlined above. In general, items that might have appeared in a village environment should be selected for authenticity. Items that are modern interjections should be selected for unobtrusiveness. It is recommended that street furniture items be black, as it helps keep these items in the visual background, and is an historic colour for painted metal items like light posts and bench ends.

Benches should be the traditional flat-slat type with cast metal ends, in a simple design. Bench castings are available with cast-in or bolted-on lettering, which could serve as a District identity marker.

Waste and Recycling Bins should have a simple design, and should be constructed so that plastic garbage-bag liners are not visible. Box-type recycling bins bearing advertising are not appropriate. The design of the waste and recycling bins should be such that they can be readily emptied from the side and not collect rain water.

Tree Guards should have a simple design, compatible with the design of waste and recycling bins.

Planters were not part of the historic streetscape but they have become established as “softeners” in business areas everywhere. In that sense, they resemble the non-functional “heritage” dormers, cupolas, and gazebos that flourish on modern shopping plazas. To the extent that planters are part of the modern commercial landscape, they should take a form that reflects the traditional garden pattern of rectangular beds. It is generally preferable to use in-ground planting, rather than planters in locations not susceptible to street salt spray and other contaminants. Hanging flower baskets should be minimized, since they were not part of the historic streetscape, and have become a symbol of urban shopping districts.

9.6 Streetscape Work

Gateways

Gateway markers at principal entrances to the District would serve to reinforce its identity and to promote the District as a place of unique historical character in the community and region. Markers should be placed so that they reinforce an existing sense of entrance, rather than at the exact point that a roadway crosses the District boundary.

Guidelines:

- Markers should be placed: At the four principal entry points on Major Mackenzie Drive and Keele Street.

9.7 Landscaping

9.7.1 Planting

No heritage permits are required for planting activities, but voluntary compliance with the guidelines in this Section can help maintain and enhance the natural heritage of the Maple and its valley.

Suitable new planting and management of existing flora are a primary means of ensuring the health of the entire ecosystem: plants contribute to stormwater and groundwater management, erosion control, and provide habitat and nutrition for wild fauna.

Guidelines:

- Maintain health of mature indigenous tree by pruning and fertilizing.
- Over time, remove unhealthy, invasive and non-indigenous species.
- Site buildings and additions to preserve suitable mature trees.
- Protect and preserve mature trees during construction.

Suitable indigenous species:

- Sugar Maple, Red Oak, Basswood, Silver Maple, Bitternut, Butternut, White Pine, Hemlock, American Elm, Red Maple, Bur Oak, White Spruce.

It is recognized that because of the urban environment and site conditions the use of non indigenous species may be suitable for road side planting. These include:

- *Acer platanoides* 'Columnare', *Tilia cordata*, *Aesculus glabra*, *Quercus alba*, *Gymnocladus dioicus*, *Syringa reticulata* and *Pyrus calleryana*.

Other suitable planting species include:

Day Lilies, Peonies, Irises, Echinacea, Campanula, Aconitum, Veronica

Unsuitable species:

- Manitoba Maple, Hawthorn, Black Locust, and Buckthorn tend to be invasive.
- Invasive, non native ornamental species, particularly Norway Maple cultivars.

Street tree planting on arterial roads should conform with Region of York guidelines. Please refer to 'Tree Planting Design Criteria' within the Region's Road Design Guidelines handbook. In general, street trees should be hardy, salt-tolerant 60 mm caliper balled and burlapped specimens, spaced at 8-12 metres on centre, planted 3 metres from any curb or utility pole and offset 1 metre from any sidewalk and 3 metres from any driveway

9.7 Landscaping

9.7.1 Warning! Invasive Plant Species



Of the roughly 2600 identified vascular plant species that grow wild in Ontario, more than 25% are aliens or exotics not native to the province. These importations have been going on since Europeans first arrived, either as deliberate introductions or as stowaways in cargoes, ballasts, and debris. However and whenever they arrived, these species have found hospitable ecological niches. Once established they make use of the plant world's full array of propagation strategies. Without the pests and competitors of their native environments, many are able to out-compete native species, and may seriously threaten entire native ecosystems, replacing a host of native plants that together provided food and habitat for native wildlife. The Federation of Ontario Naturalists has more detailed information on invasive species and their control on their website.

Guidelines:

Avoid these invasive plant species:

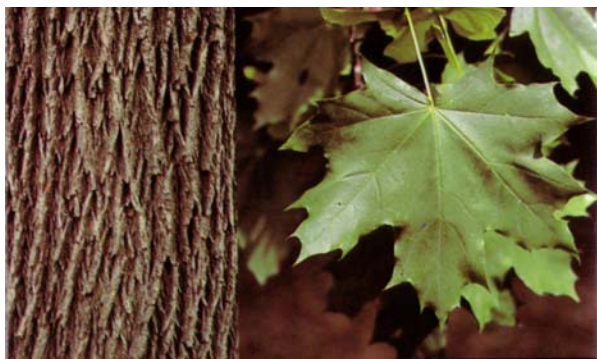

Two prime invaders are Purple Loosestrife, above, and Norway Maple, below. Both have been popular for garden and street planting, and both have proven to be highly invasive. Images from Audubon Society Field Guides.

- Purple Loosestrife
- Norway Maple
- European Birch
- Highbush Cranberry
- European Mountain Ash
- Privet
- White Mulberry
- Horse Chestnut
- Scots Pine
- Crown Vetch
- Periwinkle
- Dame's Rocket
- Winter Cress
- Silver Poplar
- Siberian Elm
- Himalayan Balsam
- Russian Olive
- Sweet Woodruff

9.8 Building Materials Checklist

All construction visible from the exterior requires a Heritage Permit. Visible materials should conform to the following standards:

9.8.1 Heritage Buildings

Appropriate Materials:

Exterior Finish:	Smooth red clay face brick, with smooth buff clay face brick as accent, or in some instances brick to match existing conditions. Wood clapboard, 4" to the weather. Smooth, painted, wood board and batten siding.
Exterior Detail:	Cut stone or reconstituted stone for trim in brick buildings. Wood shingles, stucco, or terra-cotta wall tiles in gable ends. Painted wood porches, railings, decorative trim, shutters, fascias and soffits. Painted wood gingerbread bargeboards and trim, where appropriate to the design.
Shopfronts:	Wood frames, glazing bars, and panels with glazed wood doors are preferred. Metal shopfronts, detailed and proportioned to be compatible with heritage shopfronts, are acceptable.
Roofs:	Hipped or gable roof as appropriate to the architectural style. Cedar, slate, simulated slate, or asphalt shingles of an appropriate colour. Standing seam metal roofing, if appropriate to the style. Skylights in the form of cupolas or monitors are acceptable, if appropriate to the style.
Doors:	Wood doors and frames, panel construction, may be glazed. Transom windows and paired sidelights. Wood french doors for porch entrances. Single-bay, wood panelled garage doors.
Windows:	Wood frames; single or double hung; lights as appropriate to the architectural style. Real glazing bars, or high-quality simulated glazing bars. Vertical proportion, ranging from 3:5 to 3:7.
Flashings:	Visible step flashings should be painted the colour of the wall.

9.8 Building Materials Checklist

9.8.1 Heritage Buildings

Inappropriate Materials

Exterior Finish:	Concrete block; calcite or concrete brick. Textured, clinker, or wire cut brick, except where their use is consistent with existing conditions. Precast concrete panels or cast-in-place concrete. Prefabricated metal or plastic siding. Stone or ceramic tile facing. “Rustic” clapboard or “rustic” board and batten siding; wood shake siding.
Exterior Detail:	Prefinished metal fascias and soffits. “Stock” suburban pre-manufactured shutters, railings, and trims. Unfinished pressure-treated wood decks, porches, railings, and trim.
Shopfronts:	Standard metal shopfronts and pre-finished metal spandrel material. Frameless tempered glass shopfronts.
Roofs:	Slopes or layouts not suitable to the architectural style. Non-traditional metal roofing such as pre-finished or corrugated metal. Modern skylights, when facing the street.
Doors:	“Stock” suburban door assemblies. Flush doors. Sidelights on one side only. Aluminum storm and screen doors. Sliding patio doors. Double-bay, slab, or metal garage doors. Generic or Stock stained glass window assemblies for doorlights and sidelights.

9.8 Building Materials Checklist

9.8.1 Heritage Buildings

Inappropriate Materials

- Windows: Large “picture” windows.
Curtain wall systems.
Metal, plastic, or fibreglass frames.
Metal or plastic cladding.
Awning, hopper, casement or sliding openers. Casement windows may be appropriate on California Bungalow styled buildings.
“Snap-in” or tape simulated glazing bars.
- Flashings: Pre-finished metal in inappropriate colours.

9.8.2 Non-Heritage Buildings

Note: If using the Historical Conversion approach, described in Section 9.4.1.1, follow the Heritage Building Checklist, above.

Appropriate Materials

- Exterior Finish: Use materials compatible with the original design.
Roofs: Slopes and layouts compatible with the original design.
Doors: Use materials and designs compatible with the original design.
Windows: Use windows compatible with the original design.

10.0 Sources

10.1 Documents Available for Guidance

Cultural Services has some books available that can provide useful information to people contemplating work in the District. The Vaughan Archives has historic documents and photographs. Books listed in Section 10.2 under the headings of Historic Architecture and Heritage Conservation are all useful.

Two very useful websites, containing detailed “how-to” information on heritage preservation and restoration are:

The United States National Parks Service *Preservation Briefs* at: www.cr.nps.gov/hps/tps/briefs/presbhom.htm

Parks Canada has similar guidelines at: Standards: www.pc.gc.ca/docs/pc/guide/nldclpc-sgchpc/index_E.asp

10.2 Bibliography

HISTORIC ARCHITECTURE:

Arthur, Eric and Dudley Whitney. *The Barn*. Toronto: McClelland & Stewart, 1989

Environment Canada, Parks Service. *The Buildings of Canada*. Ottawa

Ashenburg, Katherine. *Going to Town: Architectural Walking Tours in Southern Ontario*. Toronto: Macfarlane Walter & Ross 1996

Baker, John Milnes. *American House Styles: A Concise Guide*. New York: W.W. Norton & Company, 2002

Hale, Jonathan. *The Old Way of Seeing: How Architecture Lost its Magic (and How to Get it Back)*. New York: Houghton Mifflin Company, 1994

Lever, Jill & John Harris. *Illustrated Dictionary of Architecture, 800-1914*. London: Faber & Faber, 1993

McRae, Marion and Adamson, Anthony. *The Ancestral Roof: Domestic Architecture of Upper Canada*. Toronto: Clarke Irwin & Company, 1963

Plumridge, Andrew and Wim Meulenkamp. *Brickwork, Architecture and Design*. New York: Harry N. Abrams, Inc. 1993

Rempel, John I. *Building with Wood: and other aspects of nineteenth-century building in Central Canada*. Toronto: University of Toronto Press, 1980

Walker, Lester. *American Shelter: An Illustrated Encyclopedia of the American Home*. Woodstock, N.Y.: The Overlook Press, 1981

HERITAGE CONSERVATION:

Fram, Mark. *Well Preserved, The Ontario Heritage Foundation's Manual of Principles and Practice for Architectural Conservation*. Erin, Ontario: The Boston Mills Press, 1988

Fram, Mark and John Weiler, editors. *Continuity with Change, Planning for the Conservation of Man-made Heritage*. Toronto: Dundurn Press, 1984

Ontario Ministry of Culture, Tourism and Recreation. *Architectural Conservation Notes*.

Weaver, Martin E. *Conserving Buildings: A Guide to Techniques and Materials*. New York: John Wiley & Sons, Inc., 1993

PLANS AND STUDIES:

Carter, Phillip H. *Thornhill Vaughan Heritage Conservation District Study*. Vaughan: City of Vaughan, 1985

Carter, Phillip H. *Thornhill Markham Heritage Conservation District Study*. Markham: Town of Markham, 1986

Carter, Phillip H. *Collingwood Downtown Heritage Conservation District Study and Plan*. Collingwood: Town of Collingwood, 2002

Carter, Phillip H. *Kleinburg-Nashville Heritage Conservation District Study and Plan*. Vaughan: City of Vaughan, 2003

Carter, Phillip H. *Northeast Old Aurora Heritage Conservation District Study and Plan*. Aurora: Town of Aurora, 2006

Carter, Phillip H. *Heritage Review of Maple Streetscape and Urban Design Guidelines*, Vaughan: City of Vaughan, 2003

Hill, Nicholas, with Green Scheels Pidgeon Planning Consultants Ltd. *Blair Village, A Heritage Conservation District Plan in the City of Cambridge*. Cambridge: The Corporation of the City of Cambridge, 1999

KM SCI Consultants, and City of Vaughan Planning Department *Maple Streetscape and Urban Design Guidelines*, Vaughan: City of Vaughan, 1996

Project Planning Limited, *Markham Village Heritage Conservation District Plan*. Markham: Town of Markham, 1997

Stokes, Peter John. *Walton Street Heritage Conservation District Plan*. Port Hope: Town of Port Hope, 1995

Town of Markham. *Unionville Heritage Conservation District Plan*. Markham: Town of Markham, 1997

OFFICIAL DOCUMENTS:

Ontario. *Ontario Heritage Act, RSO, 1980, chapter o.18, as amended*. Toronto: Queen's Printer for Ontario, 2005

Ontario. *Ontario Heritage Conservation District Guidelines*. Toronto: Queen's Printer for Ontario, 1985

Ontario. *Provincial Policy Statement*. Toronto: Queen's Printer for Ontario, 2005

City of Vaughan. *Official Plan Amendment No 350: Maple Community Plan*. Vaughan: City of Vaughan, 1987

City of Vaughan. *Zoning By-law 1-88, as amended*. Vaughan: City of Vaughan, 1988

City of Vaughan. *Sign By-law 203-92* . Vaughan: City of Vaughan, 1992

INTERNET SOURCES:

Ontario Architecture. www.ontarioarchitecture.com. This site has very fine illustrated glossaries of building terms and building styles.

The Ontario Railway History Page. www.globalserv.net/~robkath/railnor

Part E

Appendices

Appendix A: Glossary of Architectural Terms

Italicised words are defined in other entries.

ABA rhythm: a pattern of alternating *bays*. Other rhythms might be ABBA, or AABBAA, for example.

Arcade: a running series of *arches*, supported on *piers* or *columns*.

Arch: a curved structure over an opening, supported by mutual lateral pressure.

Architrave: The lowest division of an *entablature*.

Ashlar: Squared stone masonry laid in regular courses with fine joints.

Balustrade: A *parapet* or guard consisting of *balusters* supporting a rail or *coping*. The stair rail on the open side of a household stair is a common example of a balustrade.

Barge board: The board along the edge of a *gable* roof, often decorated or pierced in Victorian houses.

Battlement: A notched *parapet*, like on a castle. Also called *castellation*. The notches are called *embassures* or *crenelles*, and the raised parts are called *merlons*.

Bay: Divisions of a building marked by windows, *pilasters*, etc. An Ontario cottage with a centre door and windows on either side would be called a 3-bay house with an *ABA rhythm*.

Bay window: A group of windows projecting beyond a main wall. Commonly with angled sides in the Victorian style, and rectangular in Edwardian.

Bipartite: In two parts.

Blind: An imitation opening on a solid wall is called blind. Thus a blind *arch*, a blind window, a blind *arcade*.

Board-and-batten: Wood siding consisting of wide vertical boards, the joints of which are covered by narrow vertical strips, or battens.

Bond: A pattern of bricklaying in a wall. In solid brick construction headers are required to tie the *wythes* of the wall together. The rhythm of the headers determines the bond.

Bow window: Curved version of the *bay window*.

Buttress: A heavy vertical masonry element built against a wall to stabilise it.

Capital: See *Orders*.

Casement: A window hinged on one side, like a door.

Chevron: A decorative pattern of V shapes, like a sergeant's stripes.

Classical: Of or deriving from the architecture of ancient Greece and Rome. Classical revival buildings typically feature *columns* and *pediments*, and are usually symmetrical in elevation.

Coffering: A pattern of square recessed panels.

Colonette: A little column, often decorative.

Colonnade: A row of *columns* supporting an *entablature*.

Column: A vertical structural member. See *orders*.

Common Bond: The standard *bond* for solid brick walls, consisting of one *header* course for every five or six courses of *running bond*.

Consul or Console: A bracket with a compound-curved profile.

Coping: A protective capping on a wall, parapet or gable, sloped to carry off rain water.

Corbel: A support projecting from a wall. Masonry that steps out course-by-course from the wall below is called corbelling.

Corinthian: See *Orders*.

Cornice: The uppermost division of an *entablature*. Also a moulded projection that crowns an element such as a wall, door or window.

Cottage: A small rustic house, or a style that imitates one. "Ontario Cottage" is a catch-phrase for a variety of one and one and a half storey house styles, some of which are actually quite large.

Course: A horizontal row of construction laid one above the other. Bricks and shingles are said to be laid in courses.

Cresting: A vertical ornament running along the top of a wall or ridge. If a rooster were a building, his comb would be cresting.

Dentil: A series of small rectangular blocks arranged in row, usually under a *cornice*. From the latin word for tooth.

Dog-tooth: A repeating decorative shape in the form of a four-lobed pyramid. Also, a brick laid so that a corner faces out from the surface of a wall.

Doric: See *Orders*.

Double-Hung: Type of window with vertically sliding sash one above the other, traditionally hung on ropes or chains from a counterbalance system concealed in the jambs. If only the lower sash is moveable it's called a single-hung window.

Eclectic: From a Greek word meaning selective. A rather vague name for late 19th and early 20th Century vernacular architecture which freely selected a bit of this and a bit of that from many previous styles. Elements of Classical, Victorian, and Italianate styles might be mixed together, for example. The term is often used disparagingly, but remarkably, the combinations are often skillful, and most eclectic buildings are quite handsome.

Entablature: In the classical *orders*, the horizontal element above a column. The meaning has been extended to include similar elements used over an opening or against a wall.

FanLight: A semi-circular transom window over a door or window, usually with radiating glazing bars, like the ribs of a fan.

Fascia: A long flat band, such as an eaves-board, a sign band over a shop window, or the undecorated strips in an architrave.

Fenestration: Windows: the pattern of windows in an elevation.

Finial: A decorative end, often in the form of a ball or spire. If it points down instead of up it can be called a pendant.

Frieze: The middle of the three divisions of an *entablature*. See *Orders*.

Gable: The roughly triangular wall at the end of a ridge roof. If the roof projects to or beyond the gable, it will take the shape of the roof structure. If the roof ends behind the wall, the gable may be freely shaped with steps, curves, or decorations.

Gambrel roof: A steeply sloped roof below a low sloped roof, creating a more usable attic. Also called barn-roof.

Georgian: An architectural style of 18th century origin, and often revived. Multi-Light *Double-hung* windows, symmetrical fronts, and modest use of *classical* ornament are hallmarks of the style. Both hipped and gable roofs were used. Evolved after the Great Fire in London, Georgian originally meant brick, but in revival the style has made use of wood and stucco siding as well.

Header: A brick laid so that its middling dimension is in the length of a wall, and its shortest dimension is vertical.

Hood mould: a thin projecting moulding over an opening, originally intended to throw off rainwater.

Impost: A block from which an arch springs.

Ionic: See Orders.

Italianate: A late 19th Century style, based on Italian country houses, featuring towers, cupolas, low hipped roofs with elaborate brackets at the soffits, and a verticality emphasised by tall narrow windows with 1 over 1 or 2 over 2 *lights*.

Keystone: An elaborated element in the centre of an *arch*. Emphasis may be provided by a contrast in colour or material, by vertical extension, and/or by projection out from the wall. The idea is that the central block is “key” to the arch, which isn’t true: each block is equally necessary.

Leaded: Glazing where small panes are divided and held together by lead strips.

Light: A single pane of glass within a *sash*. *Double-hung* windows are often described by the number of lights in the upper and lower sashes, as in 1 over 1, 2 over 2, or 12 over 12.

Lintel: A horizontal element spanning over an opening in a wall.

Loyalist: Wide spread early Ontario house style, imported by the Loyalists in the late 18th Century. Generally speaking, a version of the *Georgian* style, though usually having a gable roof. The hallmark is a panelled front door topped by a rectangular multi-pane transom, with a classical surround and cornice. When executed in wood clapboard, it is nicknamed “Yankee House”, and is indistinguishable from New England houses, but it has been built in brick and stone.

Lozenge: A diamond shaped pattern element.

Lunette: A semicircular window or panel.

Machiolation: Looks like an upside-down *battlement* projecting from a wall. Originally, in castles, there were openings at the top of the notches, through which missiles or boiling oil could be dropped on attackers below.

Mannerist: An outgrowth of the Renaissance style, it treated *classical* elements with a free hand, exaggerating scale and bending the rules. The broken pediment is a prime example of Mannerist playfulness. Revived around 1900 as Edwardian Mannerism.

Mansard Roof: A steeply sloped roof below a low-sloped roof, creating a more usable attic. Variations used in various 19th century styles include concave, convex and ogee shapes on the lower slope. Unfortunately revived as about 1960 as a tacked-on sloping band, usually of cedar shakes, in the hope of giving “natural texture” to rather ordinary flat-roofed boxes.

Modillion: Blocks or brackets under a cornice, like *dentils* but bigger and spaced widely apart.

Niche: A recess in a wall or pier, suitable for placing a statue.

Oculus: A small round or oval window. From the Latin word for “eye”.

Ogee: A double curve, concave below and convex above; a common shape for mouldings, an uncommon one for windows and arches.

Order: One of the *classical* systems of designing *colonnades*, elaborated in great detail as to proportions and geometry by classical revivalists from 1420 onwards.

Oriel, Oriel window: A bay window projecting from an upper storey.

Palladian window: A large central window topped with a *lunette* or *fan-light*, closely flanked by smaller flat-headed windows, the whole assembly surrounded by classically-inspired details.

Parapet: Originally a low wall protecting an edge with a drop, like at the side of a bridge or balcony. Also used to describe the extension of a wall above a roof, even when no one ordinarily walks there.

Pediment: In Classical architecture, the low-sloped triangular *gable* end above an *entablature*, enclosed on all sides by mouldings. The term, and its basic form has been borrowed by many styles for use above porticos, doors and windows. A segmental pediment substitutes a curved top for the original angled one, and the surrounding mouldings may be gapped in the centre, whatever the shape. A broken bed pediment has a gap in the bottom moulding, and a broken topped pediment has a gap at the top.

Pendant: A point ornament hanging down.

Pier: A large solid support for a beam, *lintel* or *arch*.

Pilaster: A vertical thickening of a wall, something like a *pier* or *column* built integrally with the wall. Sometimes used for structural purposes, sometimes purely decorative, it may be embellished with a base and capital on the model of the classical *orders*.

Pinnacle: A tall thin decoration at the top of a *pier* or *pilaster*.

Plinth: The lowest projecting part of the base of a *column*. Extended to mean any projecting base on elements such as baseboards, door frames, etc.

Pointed arch: An arch composed of two curves centred on the *springline*, whose radius is equal to the width of the opening.

Polychrome: Having many colours. Victorian red and buff brickwork is an example of polychromy.

Quoin: Alternating blocks at the corner of intersecting walls. May be expressed with contrasting material or colour. May be flush with the walls or project from it. From the French word for a “corner”.

Regency: Early 19th Century Style, following Georgian in origin, named after the Regency of George IV. Like the Prince, the style is more flamboyant than its predecessors. The scale and detail tends toward the imposing, and stone or plastered brick to imitate stone was used to emphasise solidity.

Round arch: A semicircular arch.

Rowlock: A brick laid so that its shortest dimension is in the length of a wall, and its middling dimension is vertical.

Running Bond: See *Bond*. Pattern of brickwork where all bricks are stretchers, and vertical joints lie at the midpoint of the brick below. It's now standard practice to use running bond exclusively, since brick veneer construction doesn't require headers to tie a wall together. The resulting loss of texture is an example of technology's inadvertent trend towards blandness.

Rusticated: Squared stone masonry laid in regular courses, but with the courses or the individual stones emphasized by deep joints and/or high relief in the surface treatment.

Sash: Framework holding the glass in a window.

Second Empire: A style named after Louis Napoleon's reign. Shares the vertical openings of the *Italianate* style, but usually topped with a dormered, and often curved, mansard roof, and often accompanied by a narrow tower. The Addams family lives in a Second Empire house.

Segmental arch: An arch composed of a single curve, centred below the *springline* on the centreline of the opening. Normally quite shallow.

Sign fascia: A broad flat band above a shopfront, intended for signage.

Signband: See *Sign fascia*.

Soffit: The underside of an architectural element, such as a *lintel*, *cornice*, balcony or *arch*.

Soldier: A brick laid so that its short dimension is in the length of a wall, and its long dimension is vertical.

Spandrel: The space between *arches* in an *arcade*, above the springline and below the top of the arches. Also a solid panel in a bay separating one opening from another above it.

Springline: the horizontal line from which an arch rises.

Squinch: A small arch or set of *corbelled* arches built at the interior angle of a structure to carry a superstructure of a different shape, such as a dome, spire or cupola.

Stacked bond: See *Bond*. Pattern of brickwork where all vertical joints are one above the other. Usually executed with *stretchers*, less commonly with *headers*.

Stretcher: A brick laid so that its long dimension is in the length of a wall, and its short dimension is vertical.

String course: A thin band of masonry projecting or recessed from the plane of the wall giving the effect of a moulding.

Tabernacle: A canopied *niche*.

Three-centred arch: An arch composed of three curves: a central *segmental* one of large radius, joined to two smaller flanking curves centred on the *springline*.

Transom: A horizontal member dividing an opening. Also used as short form for *transom window*.

Transom window: A window above a *transom*, most commonly over a door.

Tripartite: Having three parts.

Tympanum: The panel between the mouldings of a *pediment*.

Verandah: A large open gallery or porch, running along one or more sides of a building.

Vousoir: One of the blocks forming an arch.

Water table: Projecting masonry course near the bottom of a wall, intended to throw rain water away from the foundations.

Wythe: A vertical plane of masonry. A wall two bricks thick has an inner wythe and an outer wythe, tied together with *headers*.