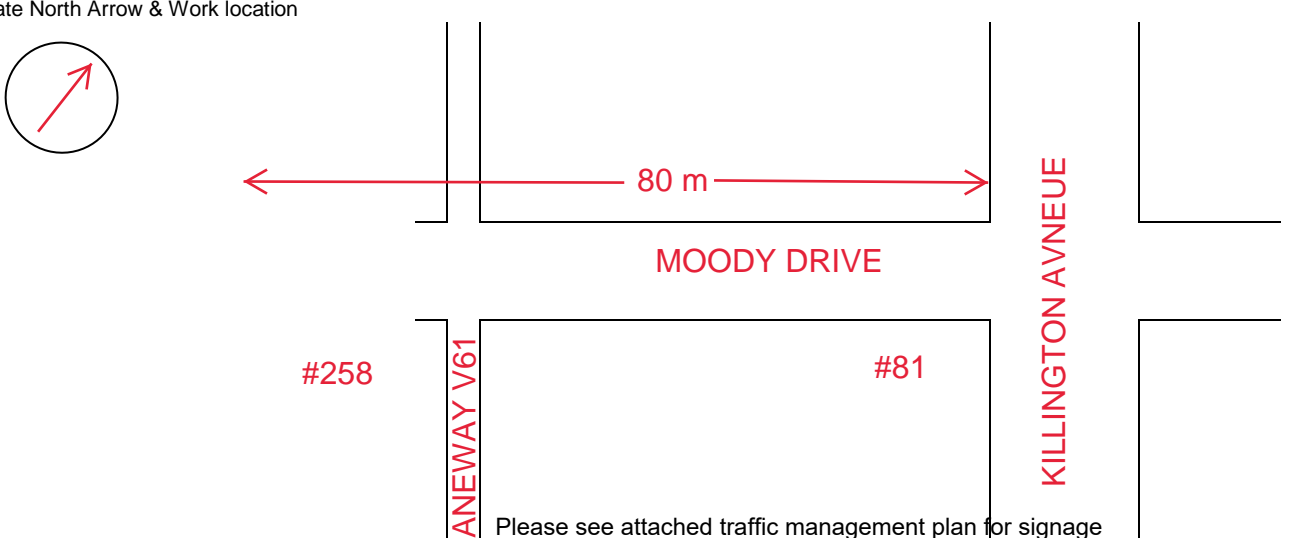

ROAD CUT PERMIT (ROAD OCCUPANCY)

PERMIT NO
2020-0492

SECTION ONE – APPLICANT INFORMATION				SECTION TWO – ADDITIONAL INFORMATION				
APPLICANT:		DATE OF APPLICATION			MUNICIPAL CONSENT NO			
REPRESENTATIVE:		YYYY	MM	DD				
TELEPHONE:		PROPOSED START DATE			PROPOSED COMPLETION DATE			
RETURN FAX:								YYYY
TYPE OF CONSTRUCTION:		PAVEMENT CUT			SIDEWALK CUT			
ADDRESS OF CONSTRUCTION:		YES <input type="checkbox"/>	NO <input type="checkbox"/>	YES <input type="checkbox"/>	NO <input type="checkbox"/>	NO <input type="checkbox"/>		
SIGNATURE OF APPLICANT OR REPRESENTATIVE <i>Randy Demmings</i>				CONSTRUCTION IN BOULEVARD OR DITCH				
SECTION THREE – DRAWING(S)								
Indicate North Arrow & Work location								
								
Please see attached traffic management plan for signage								
RESTORATION TO BE COMPLETED AS SOON AS POSSIBLE OTHERWISE FURTHER PERMITS MAY BE WITHHELD.								
SECTION FOUR – TERMS AND CONDITIONS								
<ol style="list-style-type: none"> 1. Prior to commencing construction, utility clearances must be obtained from all utilities in the City of Vaughan. Any pipe, cable, etc. that is exposed or undermined must be supported, backfilled and compacted to the satisfaction of the utility involved. (see reverse) 2. The Transportation Services Dept. must be notified 48 hours prior to commencing construction. Tel (905) 832-8585, ext. 6151 – Fax (905) 303-2005. 3. General Road Occupancy Permit Conditions apply to this permit. (see reverse) 4. A Copy of this permit must be on site at all times while working on site to verify approval when requested by City Staff. 5. This permit is not valid until signed by the City of Vaughan. 6. Return of this permit to this office with the "Date Completed" field filled in is notification of the completion of construction and restoration. 7. A one (1) year guarantee of the restoration will date from the time of inspection and acceptance of the repairs by the Director of Transportation Services, Parks and Forestry Operations. Some agreements may dictate a longer guarantee. 8. Failure to comply will render this permit void. 								
SECTION FIVE – CONDITIONS OF APPROVAL				<input type="checkbox"/> ENCROACHMENT PERMIT CONDITONS		<input type="checkbox"/> PRE-DEVELOPMENT AGREEMENT		
DATE APPROVED		APPROVED BY						
YYYY	MM	DD	DIRECTOR OF TRANSPORTATION AND FLEET MANAGEMENT SERVICES, ONHALF OF THE CITY MANAGER, PUBLIC WORKS					
SECTION SIX - COMPLETION DATE INSPECTION/REINSPECTION								
CITY SERVICES INSPECTOR: (first inspection)		INSPECTION DATE:			ACCEPTANCE?			
		YYYY	MM	DD	YES <input type="checkbox"/>	NO <input type="checkbox"/>		
INSPECTOR'S COMMENTS:								
CITY SERVICES INSPECTOR: (re-inspection)		REINSPECTION DATE:			ACCEPTANCE?			
		YYYY	MM	DD	YES <input type="checkbox"/>	NO <input type="checkbox"/>		
OFFICE USE: FINAL INSPECTION DATE:				(One Year from date of acceptance, if required)				

GENERAL ROAD CUT (ROAD OCCUPANCY) PERMIT CONDITIONS

(City of Vaughan By-Law #294-94)

THE APPLICANT FOR THIS PERMIT AGREES TO PROVIDE A MINIMUM OF **\$5,000,000** PUBLIC LIABILITY INSURANCE. THE APPLICANT ALSO AGREES AND ACCEPTS FULL RESPONSIBILITY FOR THE PROTECTION OF ALL UTILITIES, PRIVATE PROPERTY AND PERSONS AFFECTED BY THEIR OPERATIONS AND FURTHER AGREES TO INDEMNIFY AND SAVE HARMLESS THE CITY OF VAUGHAN FROM ANY AND ALL DAMAGES OR CLAIMS FOR DAMAGES OR INJURIES OR CLAIMS FOR DAMAGES OR INJURIES OR ACCIDENTS DONE TO OR CAUSED BY THE APPLICANT, OR THE APPLICANT'S EMPLOYEES, AS A RESULT OF THEIR OPERATIONS.

1. The Applicant agrees to notify the following at least 48 hours prior to commencing work:
 - Adjacent Property Owners
 - Bell Canada
 - Enbridge Gas
 - Power Stream
 - Telecommunications Company
2. All trenches must be restored as specified herein including drainage ditches, culverts and culvert headwalls. Good drainage must be maintained during the course of operations.
3. All utilities must be protected and supported to the satisfaction of the utility concerned.
4. In grassed areas adjacent to homes, sodding is required and **NEW SOD** must be **COUNTER SUNK** to match existing sod. All areas to receive sod shall have a min. of 100mm of imported screened topsoil.
5. Applicant to water and maintain sod until sod is rooted or established.
6. Applicant will not store or dump material or equipment on or within municipal right-of-ways.
7. Driveways must be repaired in the same manner as the road, specified herein. Property owners and/or residents must receive a min. of 24 hours notice prior to temporary closing of access to homes or businesses. Access can only be closed for a max. of 24 hours.
8. The road surface must be kept clear of obstructions or debris, to avoid hazard or inconvenience to public.
9. The road may not be closed without the consent in writing of the Director of Transportation Services, Parks and Forestry Operations.
10. Trees must not be damaged. Trees may not be removed unless permission in writing is received from the Director of Transportation Services, Parks and Forestry Operations. The end cuts of roots shall be neatly trimmed and painted with tree dressing.
11. Vaults, Flush to Grade, Grade Level Boxes and Pedestals are to be placed 1.0m outside of the dripline of the tree. Dripline is determined based on trunk diameter.
12. All signs are to be replaced as per the Ministry of Transportation Manual of Uniform Traffic Control Devices. Book 7 "Temporary Conditions."
13. The applicant also agrees and accepts full responsibility to supply, maintain, clean and place all barricades, warning signs delineators, flashing lights and fencing necessary for the protection of the public and the safe operation of the installation at the applicants own expense.
14. Hot Mix and/or Surface Treated pavement must be restored as per detail, "TRENCH/EXCAVATION RESTORATION."

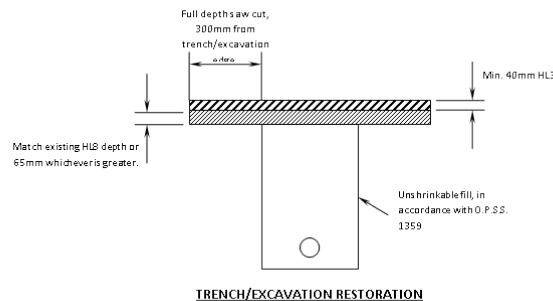

15. Trenches within the roadway must be backfilled with UNSHRINKABLE FILL, conforming to O.P.S.S. 1359, to a distance of 1.00m beyond the travel portion of the roadway. Steel or plastic plates must be placed over the trench for traffic to overpass until unshrinkable fill has fully cured.
16. Exemptions from the use of unshrinkable fill for utility cut restoration in the City of Vaughan roads may be granted by the Road Authority provided geotechnical test results are provided with a min. of 100% S.P.D. as determined by the current M.T.O. procedures.
17. Cold Mix Asphalt to be placed immediately as a temporary surface. Permanent pavement repairs must be made within 14 days or when weather permits. On some city roads experiencing heavy traffic volumes, it will be necessary to repair immediately with hot-mix asphalt.
18. Shoulders to be restored with granular 'A,' clear of all mud, clay, debris, etc. and to the original cross-section and appearance.
19. All disturbed, or affected areas including ditches and boulevard to be restored, maintained and guaranteed for one (1) full year after completion of repairs and acceptance by the Director of Transportation Services, Parks and Forestry Operations.
20. The general clean-up and restoration must commence as soon as possible, and must not be left until completion of the project.
21. The applicant agrees and accepts that approval of this permit is conditional on the Director of Transportation Services, Parks and Forestry Operations satisfaction with the quality or method of restoration of the road allowance surfaces or appurtenances.
22. The applicant also accepts the City's right to perform any necessary remedial work caused by the Applicant's operation, subject to the following conditions:
 - a. The Director of Transportation Services, Parks and Forestry Operations will give the Applicant not less than twenty-four (24) hours notice of remedial work required, unless conditions call for immediate attention;
 - b. If at the expiration of the time allowed the Applicant or his contractor has not commenced remedial work to the Director's satisfaction, he may undertake to have this work done by whatever means he deems necessary;
 - c. The Applicant agrees to reimburse the City of Vaughan for all costs involved.