

CITY-WIDE URBAN DESIGN GUIDELINES

VOLUME 2

VAUGHAN



Approved in principle by Council - February 21, 2018

Contents

01: NEW URBAN DESIGN STANDARD DETAILS

SERIES 100

- ULA 001 - PEDESTRIAN PAVING - UNIT PAVING
- ULA 002 - HEAVY DUTY INTERLOCKING CONCRETE PAVING
- ULA 003 - SOIL CELL TREE PIT IN CONCRETE PAVING
- ULA 004 - SOIL CELL TREE PIT IN UNIT PAVING
- ULA 005 - SOIL CELL TREE PIT TYPICAL LAYOUT
- ULA 006 - URBAN BOULEVARD TREE DETAIL SECTION
- ULA 007 - TREE PIT WITH SUSPENDED SLAB
- ULA 008 - TREE PIT WITH SUSPENDED SLAB AND UNIT PAVING
- ULA 009 - TREE PIT WITH SUSPENDED SLAB AND TYPICAL LAYOUT
- ULA 010 - TREE PIT WITH SUSPENDED SLAB DETAIL
- ULA 011 - TREES - BED WITH FLUSH CURB
- ULA 012 - TREES - BED WITH CURB OR WALL
- ULA 013 - TREES - BED ON STRUCTURAL SLAB
- ULA 014 - TYPICAL TREE PLANTING
- ULA 015 - TYPICAL SHRUB PLANTING
- ULA 016 - FURNISHING - BENCH
- ULA 017 - FURNISHING - BENCH
- ULA 018 - FURNISHING - BENCH
- ULA 019 - FURNISHING - BICYCLE RACK
- ULA 020 - FURNISHING - WASTE RECEPTACLE
- ULA 021 - FURNISHING - WASTE RECEPTACLE
- ULA 022 - FURNISHING - WASTE RECEPTACLE
- ULA 023 - FURNISHING - BOLLARD

02: URBAN DESIGN STANDARD DETAILS

SERIES 100 - PLANTING DETAILS

ULA 101 - DECIDUOUS TREE PLANTING DETAIL FOR TREES UNDER 90MM IN CALIPER

ULA 102 - DECIDUOUS TREE PLANTING DETAIL FOR TREES OVER 90MM IN CALIPER

ULA 103 - CONIFEROUS TREE PLANTING DETAIL FOR TREES 2500MM IN HEIGHT OR LESS

ULA 104 - CONIFEROUS TREE PLANTING DETAIL FOR TREES OVER 2500MM IN HEIGHT

ULA 105 - SHRUB PLANTING DETAIL

ULA 106 - ANNUAL AND PERENNIAL PLANTING DETAIL

ULA 107 - BARE ROOT TREE PLANTING DETAIL FOR TREES 30MM IN CALIPER OR LESS

ULA 108 - DECIDUOUS TREE SPADE DETAIL FOR TREES UNDER 90MM IN CALIPER

ULA 109 - DECIDUOUS TREE SPADE DETAIL FOR TREES OVER 90MM IN CALIPER

ULA 110A - HEAVY DUTY TREE HOARDING PROTECTION DETAIL (PLYWOOD)

ULA 110B - LIGHT DUTY TREE HOARDING PROTECTION DETAIL (SNOW FENCE)

ULA 111 - SEDIMENT CONTROL CONSTRUCTION FENCING DETAIL

SERIES 200 - BOULEVARD DETAILS

ULA 201 - BOULEVARD TREE DETAIL PLAN VIEW

ULA 202 - BOULEVARD TREE DETAIL SECTION

ULA 203 - BOULEVARD TREE DETAIL GENERAL NOTES

ULA 204 - BOULEVARD TREE DETAIL DRIVEWAY LAYOUT

ULA 205 - BOULEVARD TREE DETAIL STREET/TRAFFIC SIGN LAYOUT

ULA 206 - BOULEVARD TREE DETAIL STREET LIGHT POLE LAYOUT

ULA 207 - BOULEVARD TREE DETAIL HYDRO TRANSFORMER LAYOUT

ULA 208 - BOULEVARD TREE DETAIL FIRE HYDRANT & UTILITY PEDESTAL LAYOUT

ULA 209 - PLANTING BED AND TREE TOPSOIL DETAIL GENERAL NOTES (1 OF 2)

ULA 210 - PLANTING BED AND TREE TOPSOIL DETAIL GENERAL NOTES (2 OF 2)

ULA 211 - TERRASEEDING DETAIL GENERAL NOTES (1 OF 2)

ULA 212 - TERRASEEDING DETAIL GENERAL NOTES (2 OF 2)

SERIES 300 - HARDSCAPE DETAILS

- ULA 301 - POURED-IN-PLACE CONCRETE PAVING DETAIL
- ULA 302 - PRECAST CONCRETE UNIT PAVING ON POURED-IN-PLACE CONCRETE BASE DETAIL
- ULA 303 - ASPHALT PAVING (HEAVY-DUTY) DETAIL
- ULA 304 - ASPHALT PAVING (LIGHT-DUTY) DETAIL
- ULA 305 - LIMESTONE SCREENING PAVING DETAIL
- ULA 306 - POURED-IN-PLACE CONCRETE CURB (RAISED AND FLUSH) DETAIL
- ULA 307 - POURED-IN-PLACE CONCRETE CURB (TRAFFIC MEDIAN PLANTING BED) DETAIL
- ULA 308 - CULVERT DETAIL
- ULA 309 - ARMOUR STONE DETAIL
- ULA 310 - ARMOUR STONE RETAINING WALL DETAIL
- ULA 311 - ARMOUR STONE EDGER DETAIL

SERIES 400 - SITE FURNISHING DETAILS

- ULA 401 - METAL BENCH (DECORATIVE) DETAIL
- ULA 402 - METAL BENCH DETAIL
- ULA 403 - METAL BENCH (DECORATIVE BACKLESS) DETAIL
- ULA 404 - METAL LITTER RECEPTACLE (LARGE SIZE) DETAIL
- ULA 405 - METAL LITTER RECEPTACLE (SMALL SIZE) DETAIL
- ULA 406 - METAL LITTER RECEPTACLE (WITH LID & RECYCLING OPTIONS) DETAIL
- ULA 407 - LOCKABLE AND REMOVABLE BOLLARD DETAIL
- ULA 408 - LOCKABLE AND REMOVABLE BOLLARD (DECORATIVE) DETAIL
- ULA 409 - BICYCLE RACK DETAIL
- ULA 409A - BICYCLE RACK DETAIL WITH FOOTING
- ULA 410 - IDENTITY SIGNAGE FOR WOODLOTS AND STORM PONDS ELEVATION DETAIL
- ULA 411 - IDENTITY SIGNAGE FOR WOODLOTS AND STORM PONDS LAYOUT AND SECTION DETAILS
- ULA 412 - ACCESS GATE DETAIL
- ULA 413 - P GATE DETAIL

01:

NEW

**URBAN DESIGN
STANDARD DETAILS**

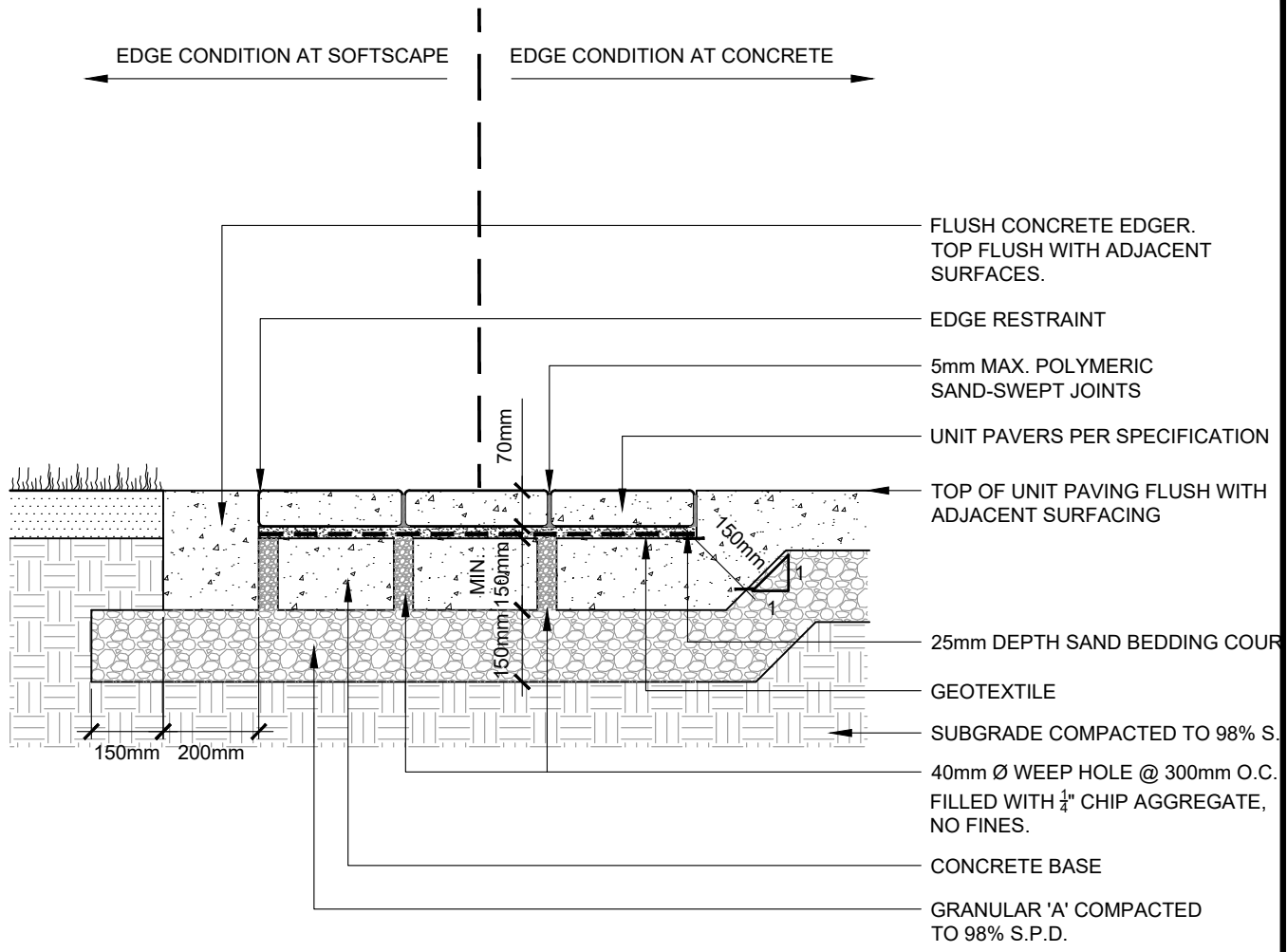

NOTES:

1. THIS TYPICAL DETAIL IS INTENDED TO CONVEY INTENT AND IS FOR REFERENCE ONLY. IT SHALL NOT BE USED AS PART OF THE CONSTRUCTION DRAWING PACKAGE OR SITE PLAN APPLICATION.
2. EDGE RESTRAINT: PERMALOC STRUCTURE ALUMINUM EDGE RESTRAINT.
3. 2.0% CROSS SLOPE ACROSS TOP OF UNIT PAVERS TYP. UNLESS INDICATED OTHERWISE ON PLANS



VAUGHAN

DEVELOPMENT PLANNING DEPT.
URBAN DESIGN DIVISION

PEDESTRIAN PAVING - UNIT PAVING

NOTE: THIS TYPICAL DETAIL IS INTENDED TO PROVIDE DESIGN DIRECTION AND IS FOR REFERENCE ONLY. IT MAY BE USED AS PART OF THE CONSTRUCTION PACKAGE OR SITE PLAN APPLICATION PROVIDED THE DETAIL IS CERTIFIED BY A REGISTERED LANDSCAPE ARCHITECT OR PROFESSIONAL ENGINEER AS APPLICABLE.

DRAWN & DESIGNED: _____	STD. DWG. NO. _____
NOT TO SCALE DATE: _____	ULA 001

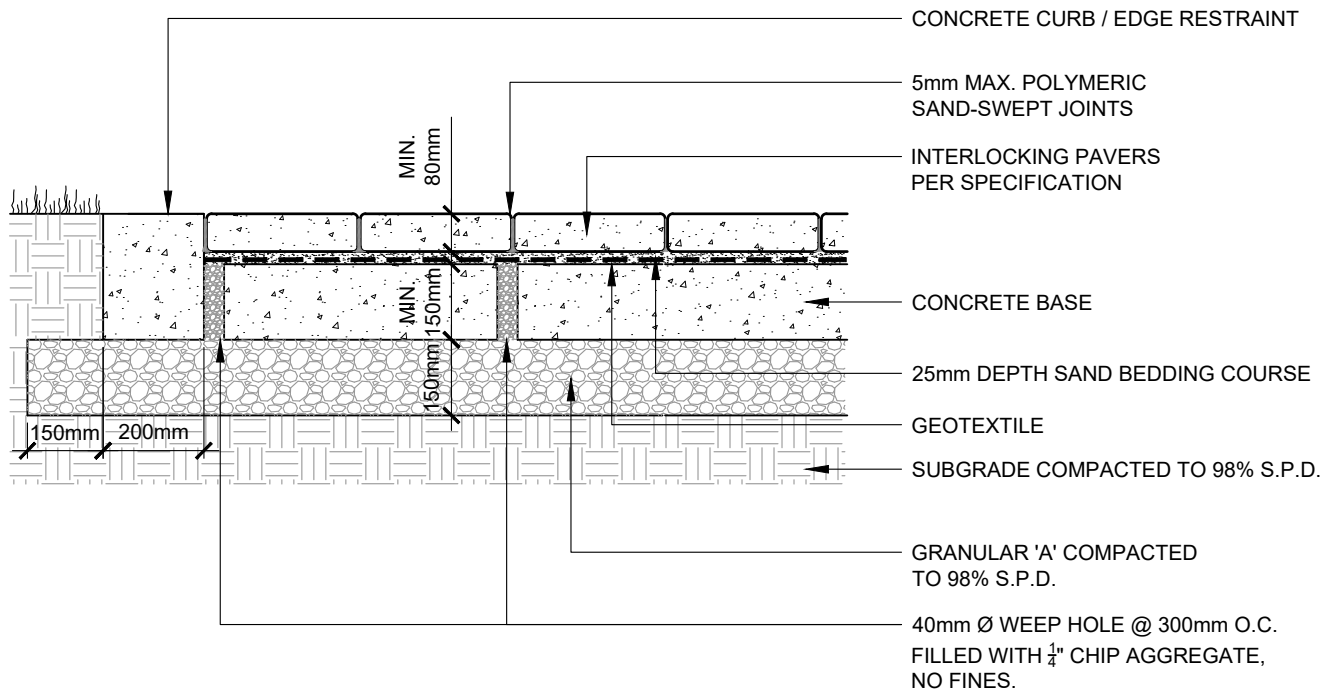

NOTES:

1. EDGE RESTRAINT: PERMALOC STRUCTURE ALUMINUM EDGE RESTRAINT.
2. 2.0% CROSS SLOPE ACROSS TOP OF UNIT PAVERS TYP. UNLESS INDICATED OTHERWISE ON PLANS



VAUGHAN
 DEVELOPMENT PLANNING DEPT.
 URBAN DESIGN DIVISION

**HEAVY DUTY INTERLOCKING
 CONCRETE PAVING**

NOTE: THIS TYPICAL DETAIL IS INTENDED TO PROVIDE DESIGN DIRECTION AND IS FOR REFERENCE ONLY. IT MAY BE USED AS PART OF THE CONSTRUCTION PACKAGE OR SITE PLAN APPLICATION PROVIDED THE DETAIL IS CERTIFIED BY A REGISTERED LANDSCAPE ARCHITECT OR PROFESSIONAL ENGINEER AS APPLICABLE.

DRAWN & DESIGNED: _____

STD. DWG. NO.

NOT TO SCALE DATE: _____

ULA 002

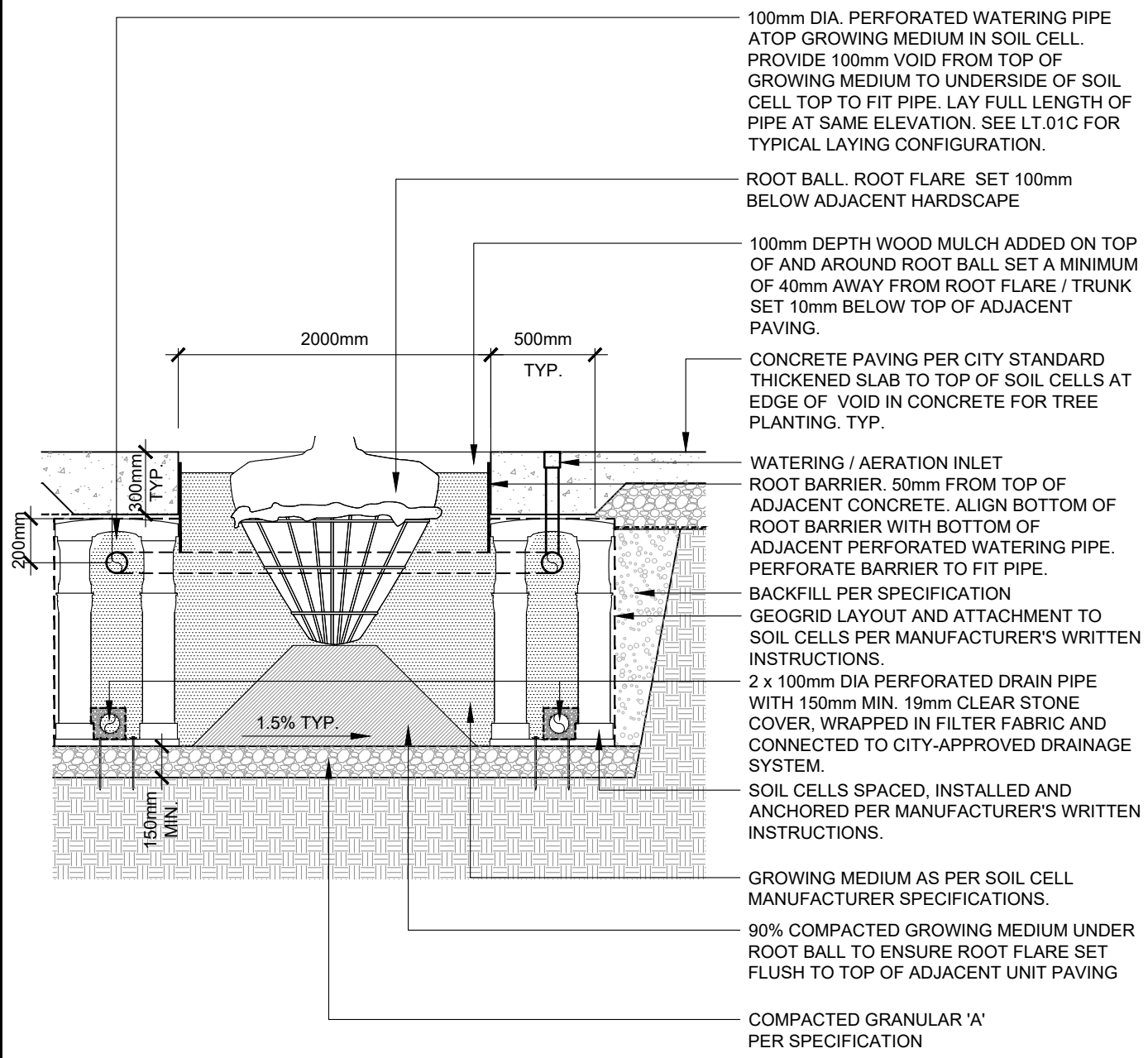

100mm DIA. PERFORATED WATERING PIPE ATOP GROWING MEDIUM IN SOIL CELL. PROVIDE 100mm VOID FROM TOP OF GROWING MEDIUM TO UNDERSIDE OF SOIL CELL TOP TO FIT PIPE. LAY FULL LENGTH OF PIPE AT SAME ELEVATION. SEE LT.01C FOR TYPICAL LAYING CONFIGURATION.

ROOT BALL. ROOT FLARE SET 100mm BELOW ADJACENT HARDSCAPE

100mm DEPTH WOOD MULCH ADDED ON TOP OF AND AROUND ROOT BALL SET A MINIMUM OF 40mm AWAY FROM ROOT FLARE / TRUNK SET 10mm BELOW TOP OF ADJACENT PAVING.

CONCRETE PAVING PER CITY STANDARD THICKENED SLAB TO TOP OF SOIL CELLS AT EDGE OF VOID IN CONCRETE FOR TREE PLANTING. TYP.

WATERING / AERATION INLET

ROOT BARRIER. 50mm FROM TOP OF ADJACENT CONCRETE. ALIGN BOTTOM OF ROOT BARRIER WITH BOTTOM OF ADJACENT PERFORATED WATERING PIPE. PERFORATE BARRIER TO FIT PIPE.

BACKFILL PER SPECIFICATION GEOGRID LAYOUT AND ATTACHMENT TO SOIL CELLS PER MANUFACTURER'S WRITTEN INSTRUCTIONS.

2 x 100mm DIA PERFORATED DRAIN PIPE WITH 150mm MIN. 19mm CLEAR STONE COVER, WRAPPED IN FILTER FABRIC AND CONNECTED TO CITY-APPROVED DRAINAGE SYSTEM.

SOIL CELLS SPACED, INSTALLED AND ANCHORED PER MANUFACTURER'S WRITTEN INSTRUCTIONS.

GROWING MEDIUM AS PER SOIL CELL MANUFACTURER SPECIFICATIONS.

90% COMPACTED GROWING MEDIUM UNDER ROOT BALL TO ENSURE ROOT FLARE SET FLUSH TO TOP OF ADJACENT UNIT PAVING

COMPACTED GRANULAR 'A' PER SPECIFICATION

NOTES:

1. TREES SHALL HAVE ACCESS TO A MINIMUM OF 20 CUBIC METERS OF GROWING MEDIUM IN A SHARED TREE PIT OR 30 CUBIC METERS OF GROWING MEDIUM IN A STAND-ALONE TREE PIT.
2. REQUIRED SOIL VOLUMES MAY BE ACHIEVED USING ANY SOIL CELL PRODUCT.
3. ALL TREES MUST BE IRRIGATED. IRRIGATION IS TO BE DISTRIBUTED EVENLY THROUGHOUT TREE PIT. IRRIGATION MAY BE PASSIVE (UTILIZING STORMWATER) OR ACTIVE (UTILIZING AN IRRIGATION SYSTEM)
4. SOIL CELL AND/OR SUSPENDED SLAB DETAIL MUST BE STAMPED BY STRUCTURAL ENGINEER FOR SITE PLAN APPROVAL SUBMISSION.
5. CONFIRM GRADING ON SITE. ALL PROPOSED GRADES TO MATCH EXISTING CONDITIONS.



VAUGHAN
DEVELOPMENT PLANNING DEPT.
URBAN DESIGN DIVISION

**SOIL CELL TREE PIT IN
CONCRETE PAVING**

NOTE: THIS TYPICAL DETAIL IS INTENDED TO PROVIDE DESIGN DIRECTION AND IS FOR REFERENCE ONLY. IT MAY BE USED AS PART OF THE CONSTRUCTION PACKAGE OR SITE PLAN APPLICATION PROVIDED THE DETAIL IS CERTIFIED BY A REGISTERED LANDSCAPE ARCHITECT OR PROFESSIONAL ENGINEER AS APPLICABLE.

DRAWN & DESIGNED: _____
NOT TO SCALE DATE: _____

STD. DWG. NO.
ULA 003

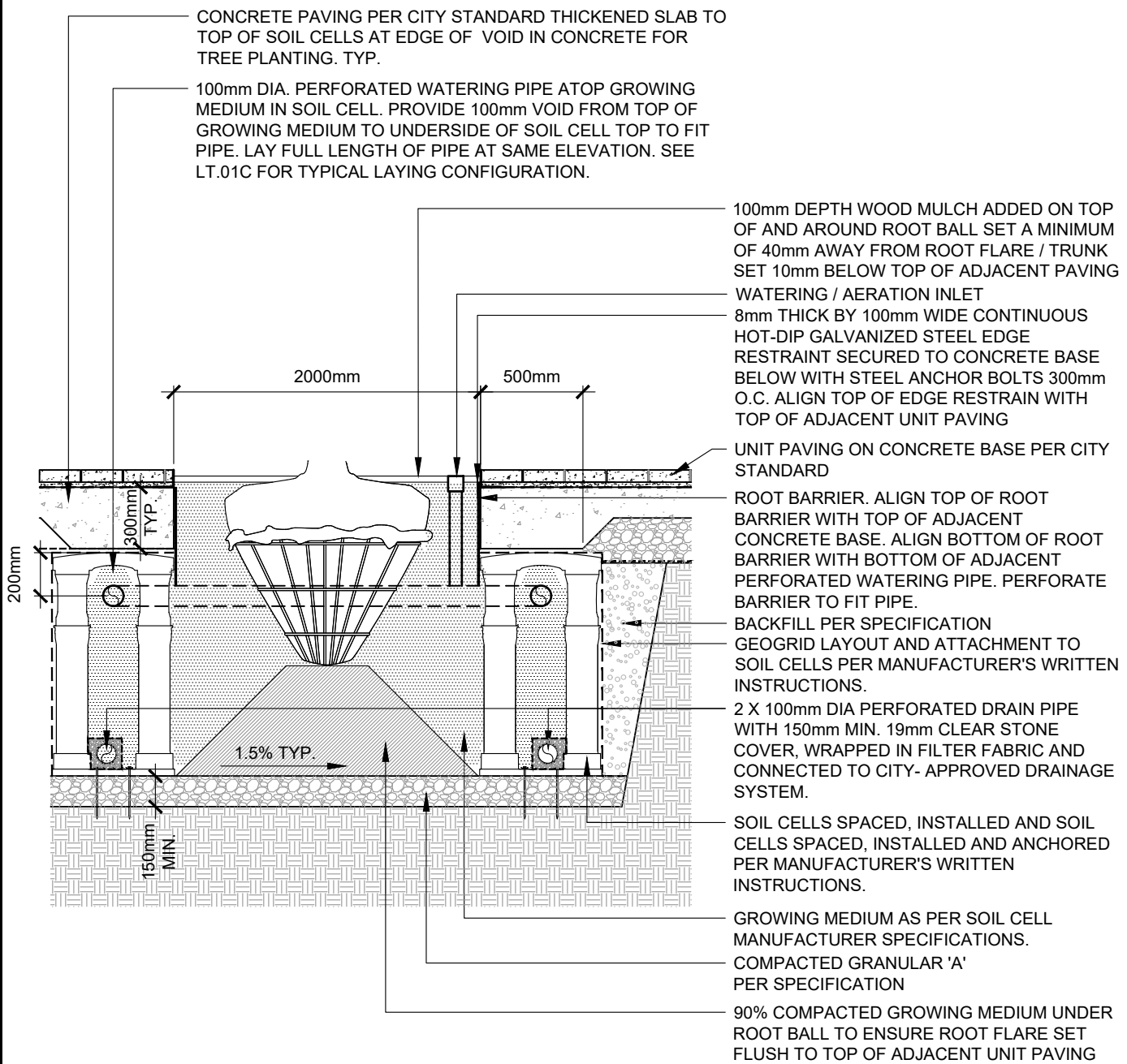

CONCRETE PAVING PER CITY STANDARD THICKENED SLAB TO TOP OF SOIL CELLS AT EDGE OF VOID IN CONCRETE FOR TREE PLANTING. TYP.

100mm DIA. PERFORATED WATERING PIPE ATOP GROWING MEDIUM IN SOIL CELL. PROVIDE 100mm VOID FROM TOP OF GROWING MEDIUM TO UNDERSIDE OF SOIL CELL TOP TO FIT PIPE. LAY FULL LENGTH OF PIPE AT SAME ELEVATION. SEE LT.01C FOR TYPICAL LAYING CONFIGURATION.

100mm DEPTH WOOD MULCH ADDED ON TOP OF AND AROUND ROOT BALL SET A MINIMUM OF 40mm AWAY FROM ROOT FLARE / TRUNK SET 10mm BELOW TOP OF ADJACENT PAVING WATERING / AERATION INLET

8mm THICK BY 100mm WIDE CONTINUOUS HOT-DIP GALVANIZED STEEL EDGE RESTRAINT SECURED TO CONCRETE BASE BELOW WITH STEEL ANCHOR BOLTS 300mm O.C. ALIGN TOP OF EDGE RESTRAINT WITH TOP OF ADJACENT UNIT PAVING

UNIT PAVING ON CONCRETE BASE PER CITY STANDARD

ROOT BARRIER. ALIGN TOP OF ROOT BARRIER WITH TOP OF ADJACENT CONCRETE BASE. ALIGN BOTTOM OF ROOT BARRIER WITH BOTTOM OF ADJACENT PERFORATED WATERING PIPE. PERFORATE BARRIER TO FIT PIPE.

BACKFILL PER SPECIFICATION GEOGRID LAYOUT AND ATTACHMENT TO SOIL CELLS PER MANUFACTURER'S WRITTEN INSTRUCTIONS.

2 X 100mm DIA PERFORATED DRAIN PIPE WITH 150mm MIN. 19mm CLEAR STONE COVER, WRAPPED IN FILTER FABRIC AND CONNECTED TO CITY- APPROVED DRAINAGE SYSTEM.

SOIL CELLS SPACED, INSTALLED AND SOIL CELLS SPACED, INSTALLED AND ANCHORED PER MANUFACTURER'S WRITTEN INSTRUCTIONS.

GROWING MEDIUM AS PER SOIL CELL MANUFACTURER SPECIFICATIONS.

COMPACTED GRANULAR 'A' PER SPECIFICATION

90% COMPACTED GROWING MEDIUM UNDER ROOT BALL TO ENSURE ROOT FLARE SET FLUSH TO TOP OF ADJACENT UNIT PAVING

NOTES:

1. TREES SHALL HAVE ACCESS TO A MINIMUM OF 20 CUBIC METERS OF GROWING MEDIUM IN A SHARED TREE PIT OR 30 CUBIC METERS OF GROWING MEDIUM IN A STAND-ALONE TREE PIT.
2. REQUIRED SOIL VOLUMES MAY BE ACHIEVED USING ANY SOIL CELL PRODUCT.
3. ALL TREES MUST BE IRRIGATED. IRRIGATION IS TO BE DISTRIBUTED EVENLY THROUGHOUT TREE PIT. IRRIGATION MAY BE PASSIVE (UTILIZING STORMWATER) OR ACTIVE (UTILIZING AN IRRIGATION SYSTEM)
4. SOIL CELL AND/OR SUSPENDED SLAB DETAIL MUST BE STAMPED BY STRUCTURAL ENGINEER FOR SITE PLAN APPROVAL SUBMISSION.
5. CONFIRM GRADING ON SITE. ALL PROPOSED GRADES TO MATCH EXISTING CONDITIONS.



VAUGHAN
DEVELOPMENT PLANNING DEPT.
URBAN DESIGN DIVISION

SOIL CELL TREE PIT IN UNIT PAVING

NOTE: THIS TYPICAL DETAIL IS INTENDED TO PROVIDE DESIGN DIRECTION AND IS FOR REFERENCE ONLY. IT MAY BE USED AS PART OF THE CONSTRUCTION PACKAGE OR SITE PLAN APPLICATION PROVIDED THE DETAIL IS CERTIFIED BY A REGISTERED LANDSCAPE ARCHITECT OR PROFESSIONAL ENGINEER AS APPLICABLE.

DRAWN & DESIGNED: _____
NOT TO SCALE DATE: _____

STD. DWG. NO.
ULA 004

OPENING IN CONCRETE C/W 25 - 50mm DEPTH MULCH ADDED ON TOP OF AND AROUND ROOT BALL SET A MINIMUM OF 40mm AWAY FROM ROOT FLARE / TRUNK SET 30mm BELOW TOP OF ADJACENT PAVING

WATERING / AERATION INLET



PERFORATED DRAINAGE PIPE

OUTLINE OF SOIL CELL BELOW

PERFORATED WATERING PIPE LAID IN FIGURE-EIGHT CONFIGURATION AS SHOWN



ADJACENT SURFACING

PRIVATE PROPERTY PUBLIC RIGHT-OF-WAY

8000 - 12000mm TYP.

ADJACENT SURFACING

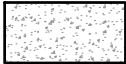
LEGEND

-  CONCRETE PAVING W/ JOINTING.
-  OUTLINE OF SOIL CELL BELOW
-  PROPERTY LINE

NOTES:

1. TREES SHALL HAVE ACCESS TO A MINIMUM OF 20 CUBIC METERS OF GROWING MEDIUM IN A SHARED TREE PIT OR 30 CUBIC METERS OF GROWING MEDIUM IN A STAND-ALONE TREE PIT.
2. REQUIRED SOIL VOLUMES MAY BE ACHIEVED USING ANY SOIL CELL PRODUCT.
3. ALL TREES MUST BE IRRIGATED. IRRIGATION IS TO BE DISTRIBUTED EVENLY THROUGHOUT TREE PIT. IRRIGATION MAY BE PASSIVE (UTILIZING STORMWATER) OR ACTIVE (UTILIZING AN IRRIGATION SYSTEM)
4. SOIL CELL AND/OR SUSPENDED SLAB DETAIL MUST BE STAMPED BY STRUCTURAL ENGINEER FOR SITE PLAN APPROVAL SUBMISSION.
5. CONFIRM GRADING ON SITE. ALL PROPOSED GRADES TO MATCH EXISTING CONDITIONS.

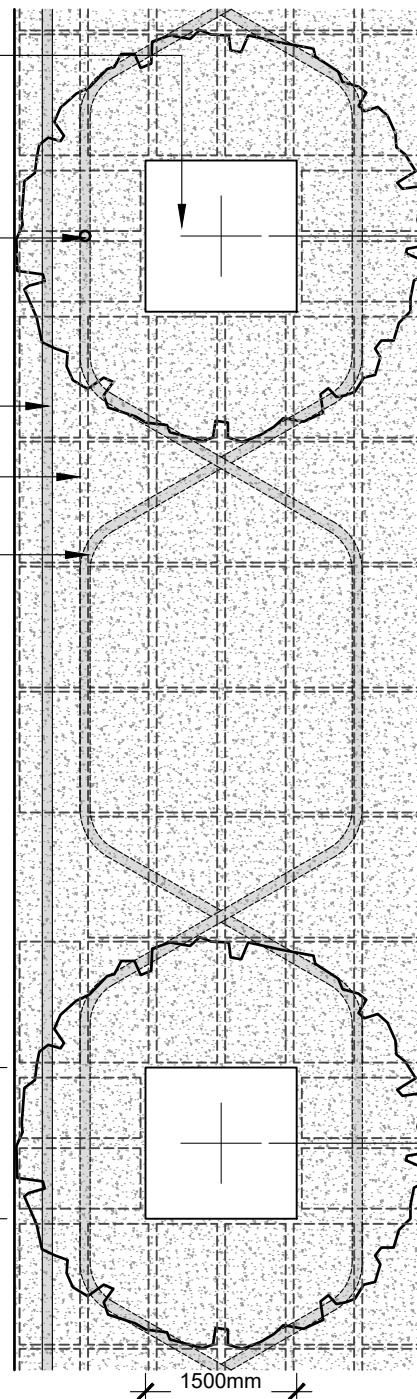



VAUGHAN
DEVELOPMENT PLANNING DEPT.
URBAN DESIGN DIVISION

SOIL CELL TREE PIT TYPICAL LAYOUT

NOTE: THIS TYPICAL DETAIL IS INTENDED TO PROVIDE DESIGN DIRECTION AND IS FOR REFERENCE ONLY. IT MAY BE USED AS PART OF THE CONSTRUCTION PACKAGE OR SITE PLAN APPLICATION PROVIDED THE DETAIL IS CERTIFIED BY A REGISTERED LANDSCAPE ARCHITECT OR PROFESSIONAL ENGINEER AS APPLICABLE.

DRAWN & DESIGNED: _____
NOT TO SCALE DATE: _____

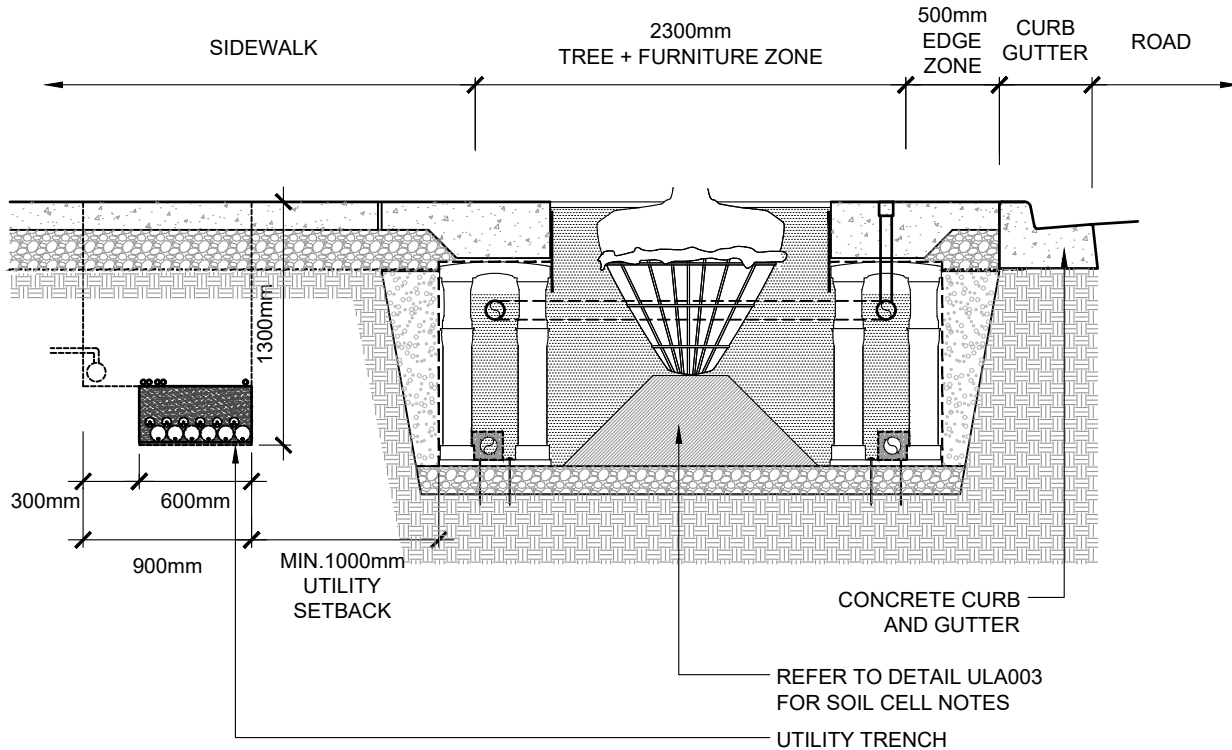
STD. DWG. NO.
ULA 005



NOTES:

1. TREES SHALL HAVE ACCESS TO A MINIMUM OF 20 CUBIC METERS OF GROWING MEDIUM IN A SHARED TREE PIT OR 30 CUBIC METERS OF GROWING MEDIUM IN A STAND-ALONE TREE PIT.
2. REQUIRED SOIL VOLUMES MAY BE ACHIEVED USING ANY SOIL CELL PRODUCT.
3. ALL TREES MUST BE IRRIGATED. IRRIGATION IS TO BE DISTRIBUTED EVENLY THROUGHOUT TREE PIT. IRRIGATION MAY BE PASSIVE (UTILIZING STORMWATER) OR ACTIVE (UTILIZING AN IRRIGATION SYSTEM)
4. SOIL CELL AND/OR SUSPENDED SLAB DETAIL MUST BE STAMPED BY STRUCTURAL ENGINEER FOR SITE PLAN APPROVAL SUBMISSION.
5. CONFIRM GRADING ON SITE. ALL PROPOSED GRADES TO MATCH EXISTING CONDITIONS.



URBAN BOULEVARD TREE DETAIL SECTION

NOTE: THIS TYPICAL DETAIL IS INTENDED TO PROVIDE DESIGN DIRECTION AND IS FOR REFERENCE ONLY. IT MAY BE USED AS PART OF THE CONSTRUCTION PACKAGE OR SITE PLAN APPLICATION PROVIDED THE DETAIL IS CERTIFIED BY A REGISTERED LANDSCAPE ARCHITECT OR PROFESSIONAL ENGINEER AS APPLICABLE.

DRAWN & DESIGNED: _____

STD. DWG. NO.

NOT TO SCALE DATE: _____

ULA 006

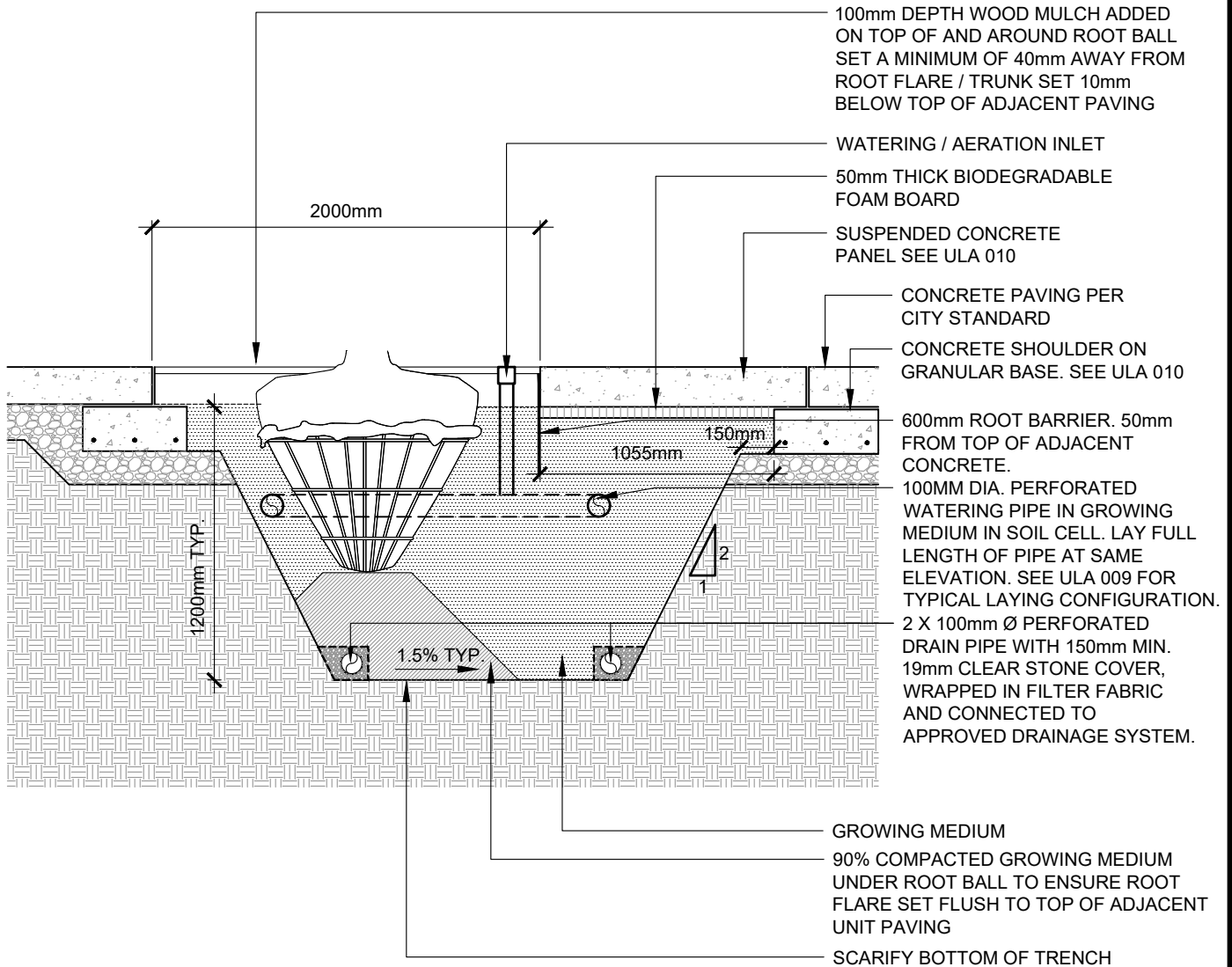

NOTES:

1. TREES SHALL HAVE ACCESS TO A MINIMUM OF 20 CUBIC METERS OF GROWING MEDIUM IN A SHARED TREE PIT OR 30 CUBIC METERS OF GROWING MEDIUM IN A STAND-ALONE TREE PIT.
2. REQUIRED SOIL VOLUMES MAY BE ACHIEVED USING ANY SOIL CELL PRODUCT.
3. ALL TREES MUST BE IRRIGATED. IRRIGATION IS TO BE DISTRIBUTED EVENLY THROUGHOUT TREE PIT. IRRIGATION MAY BE PASSIVE (UTILIZING STORMWATER) OR ACTIVE (UTILIZING AN IRRIGATION SYSTEM)
4. SOIL CELL AND/OR SUSPENDED SLAB DETAIL MUST BE STAMPED BY STRUCTURAL ENGINEER FOR SITE PLAN APPROVAL SUBMISSION.
5. CONFIRM GRADING ON SITE. ALL PROPOSED GRADES TO MATCH EXISTING CONDITIONS.



VAUGHAN
DEVELOPMENT PLANNING DEPT.
URBAN DESIGN DIVISION

TREE PIT WITH SUSPENDED SLAB

NOTE: THIS TYPICAL DETAIL IS INTENDED TO PROVIDE DESIGN DIRECTION AND IS FOR REFERENCE ONLY. IT MAY BE USED AS PART OF THE CONSTRUCTION PACKAGE OR SITE PLAN APPLICATION PROVIDED THE DETAIL IS CERTIFIED BY A REGISTERED LANDSCAPE ARCHITECT OR PROFESSIONAL ENGINEER AS APPLICABLE.

DRAWN & DESIGNED: _____
NOT TO SCALE DATE: _____

STD. DWG. NO.
ULA 007

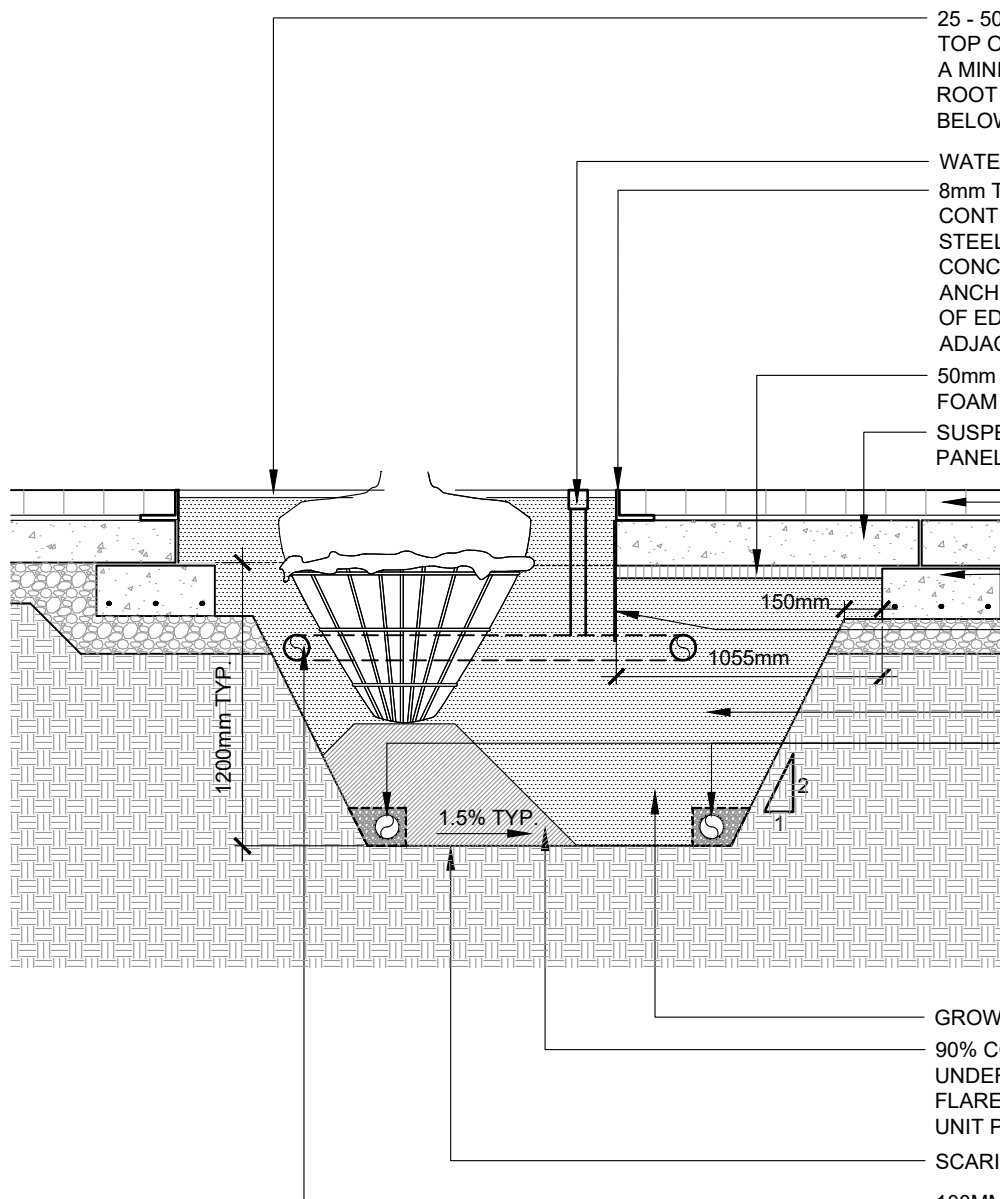

25 - 50mm DEPTH MULCH ADDED ON TOP OF AND AROUND ROOT BALL SET A MINIMUM OF 40mm AWAY FROM ROOT FLARE / TRUNK SET 10mm BELOW TOP OF ADJACENT PAVING

WATERING / AERATION INLET

8mm THICK BY 100mm WIDE CONTINUOUS HOT-DIP GALVANIZED STEEL EDGE RESTRAINT SECURED TO CONCRETE BASE BELOW WITH STEEL ANCHOR BOLTS 300mm O.C. ALIGN TOP OF EDGE RESTRAINT WITH TOP OF ADJACENT UNIT PAVING

50mm THICK BIODEGRADABLE FOAM BOARD

SUSPENDED CONCRETE PANEL SEE ULA 010

UNIT PAVING ON CONCRETE BASE PER CITY STANDARD

CONCRETE SHOULDER ON GRANULAR BASE SEE ULA 010

600mm ROOT BARRIER. 50mm FROM TOP OF ADJACENT CONCRETE.

GROWING MEDIUM

2 x 100mm DIA PERFORATED DRAIN PIPE WITH 150mm MIN. 19mm CLEAR STONE COVER, WRAPPED IN FILTER FABRIC AND CONNECTED TO CITY-APPROVED DRAINAGE SYSTEM.

GROWING MEDIUM

90% COMPACTED GROWING MEDIUM UNDER ROOT BALL TO ENSURE ROOT FLARE SET FLUSH TO TOP OF ADJACENT UNIT PAVING

SCARIFY BOTTOM OF TRENCH

100MM DIA. PERFORATED WATERING PIPE IN GROWING MEDIUM IN SOIL CELL. LAY FULL LENGTH OF PIPE AT SAME ELEVATION. SEE ULA 009 FOR TYPICAL LAYING CONFIGURATION

NOTES:

1. TREES SHALL HAVE ACCESS TO A MINIMUM OF 20 CUBIC METERS OF GROWING MEDIUM IN A SHARED TREE PIT OR 30 CUBIC METERS OF GROWING MEDIUM IN A STAND-ALONE TREE PIT.
2. REQUIRED SOIL VOLUMES MAY BE ACHIEVED USING ANY SOIL CELL PRODUCT.
3. ALL TREES MUST BE IRRIGATED. IRRIGATION IS TO BE DISTRIBUTED EVENLY THROUGHOUT TREE PIT. IRRIGATION MAY BE PASSIVE (UTILIZING STORMWATER) OR ACTIVE (UTILIZING AN IRRIGATION SYSTEM)
4. SOIL CELL AND/OR SUSPENDED SLAB DETAIL MUST BE STAMPED BY STRUCTURAL ENGINEER FOR SITE PLAN APPROVAL SUBMISSION.
5. CONFIRM GRADING ON SITE. ALL PROPOSED GRADES TO MATCH EXISTING CONDITIONS.



VAUGHAN
DEVELOPMENT PLANNING DEPT.
URBAN DESIGN DIVISION

TREE PIT WITH SUSPENDED SLAB AND UNIT PAVING

NOTE: THIS TYPICAL DETAIL IS INTENDED TO PROVIDE DESIGN DIRECTION AND IS FOR REFERENCE ONLY. IT MAY BE USED AS PART OF THE CONSTRUCTION PACKAGE OR SITE PLAN APPLICATION PROVIDED THE DETAIL IS CERTIFIED BY A REGISTERED LANDSCAPE ARCHITECT OR PROFESSIONAL ENGINEER AS APPLICABLE.

DRAWN & DESIGNED: _____
NOT TO SCALE DATE: _____

STD. DWG. NO.
ULA 008

OPENING IN CONCRETE C/W 25 - 50mm DEPTH MULCH ADDED ON TOP OF AND AROUND ROOT BALL SET A MINIMUM OF 40mm AWAY FROM ROOT FLARE / TRUNK SET 30mm BELOW TOP OF ADJACENT PAVING. MULCH TO CONCEAL CONCRETE SHOULDER.

WATERING / AERATION INLET

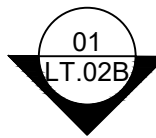

PERFORATED DRAINAGE PIPE

PERFORATED WATERING PIPE LAID IN FIGURE-EIGHT CONFIGURATION AS SHOWN

OUTLINE OF CONCRETE SHOULDER BELOW. SEE 04/LT.02D.

ADJACENT HARD SURFACING

8000 - 12000mm TYP.

ADJACENT HARD SURFACING

PRIVATE PROPERTY PUBLIC RIGHT-OF-WAY

LEGEND

- Ⓐ CONCRETE PANEL TYPE 'A' SEE LT.02D
- Ⓑ CONCRETE PANEL TYPE 'A' SEE LT.02D
- PROPERTY LINE

NOTES:

1. THIS TYPICAL DETAIL IS INTENDED TO CONVEY INTENT AND IS FOR REFERENCE ONLY. IT SHALL NOT BE USED AS PART OF THE CONSTRUCTION DRAWING PACKAGE OR SITE PLAN APPLICATION.
2. TREES SHALL HAVE ACCESS TO A MINIMUM OF 20 CUBIC METERS OF GROWING MEDIUM IN A SHARED TREE PIT OR 30 CUBIC METERS OF GROWING MEDIUM IN A STAND-ALONE TREE PIT.
3. REQUIRED SOIL VOLUMES MAY BE ACHIEVED USING ANY SOIL CELL PRODUCT.
4. ALL TREES MUST BE IRRIGATED. IRRIGATION IS TO BE DISTRIBUTED EVENLY THROUGHOUT TREE PIT. IRRIGATION MAY BE PASSIVE (UTILIZING STORMWATER) OR ACTIVE (UTILIZING AN IRRIGATION SYSTEM)
5. SOIL CELL AND/OR SUSPENDED SLAB DETAIL MUST BE STAMPED BY STRUCTURAL ENGINEER FOR SITE PLAN APPROVAL SUBMISSION.
6. CONFIRM GRADING ON SITE. ALL PROPOSED GRADES TO MATCH EXISTING CONDITIONS.
7. DETAIL NOT TO BE USED UNLESS REVIEWED, STAMPED AND CERTIFIED BY REGISTERED LANDSCAPE ARCHITECT.

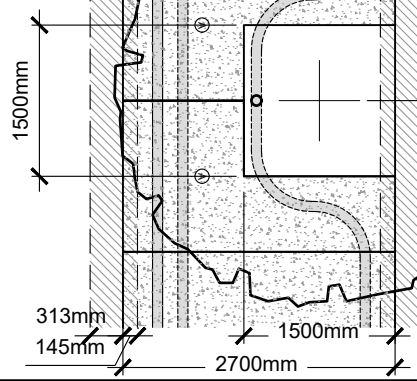

VAUGHAN
DEVELOPMENT PLANNING DEPT.
URBAN DESIGN DIVISION

**TREE PIT WITH SUSPENDED SLAB
TYPICAL LAYOUT**

NOTE: THIS TYPICAL DETAIL IS INTENDED TO PROVIDE DESIGN DIRECTION AND IS FOR REFERENCE ONLY. IT MAY BE USED AS PART OF THE CONSTRUCTION PACKAGE OR SITE PLAN APPLICATION PROVIDED THE DETAIL IS CERTIFIED BY A REGISTERED LANDSCAPE ARCHITECT OR PROFESSIONAL ENGINEER AS APPLICABLE.

DRAWN & DESIGNED: _____
NOT TO SCALE DATE: _____

STD. DWG. NO.
ULA 009

**01: SUSPENDED CONCRETE
PANEL 'A' - TREE OPENING**

TYPICAL PLAN
SCALE 1:40

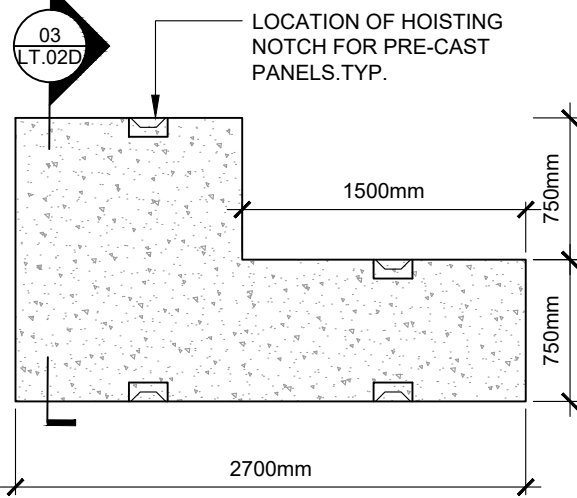

**02: SUSPENDED CONCRETE
PANEL 'B' - BRIDGING PANEL**

TYPICAL PLAN
SCALE 1:40

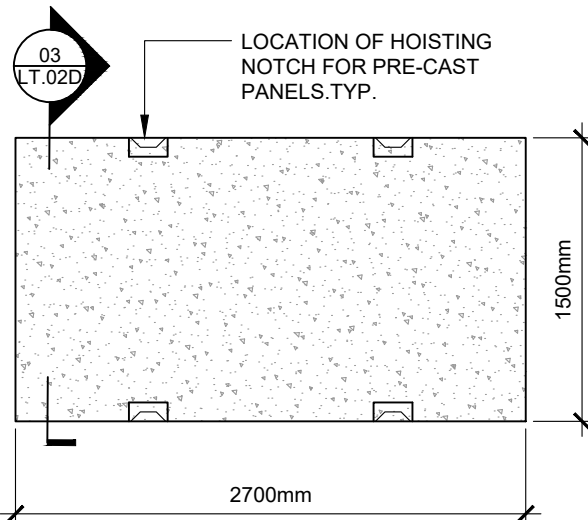

**03: SUSPENDED CONCRETE
TYPICAL SECTION**

SCALE 1:20

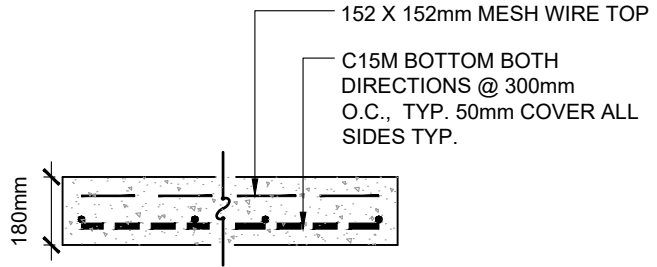

**04: SUSPENDED CONCRETE
SHOULDER TYPICAL SECTION**

SCALE 1:20

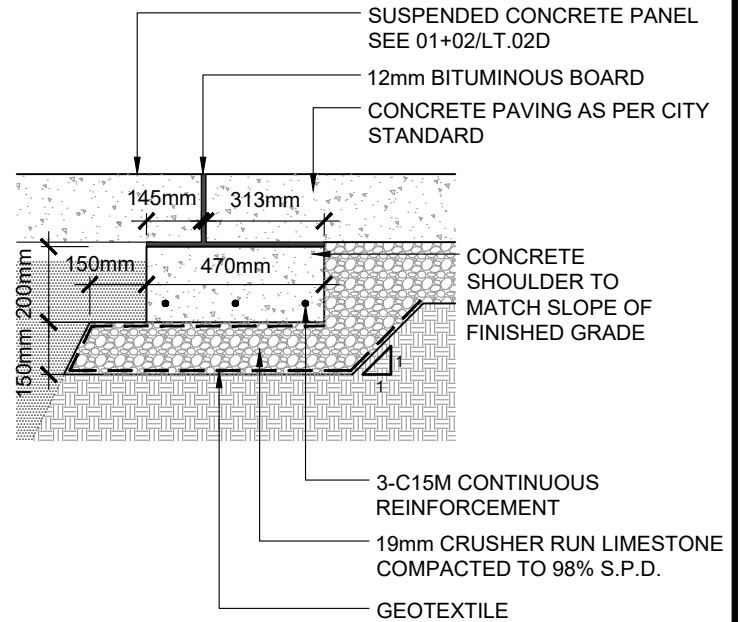

NOTES:

1. PROVIDE EXPANSION JOINTS BETWEEN CONCRETE PANELS. TYP.
2. REINFORCED CONCRETE SUSPENDED SLAB DETAIL MUST BE DESIGNED AND STAMPED BY STRUCTURAL ENGINEER FOR SITE PLAN APPROVAL SUBMISSION.



VAUGHAN
DEVELOPMENT PLANNING DEPT.
URBAN DESIGN DIVISION

**TREE PIT WITH SUSPENDED SLAB
DETAILS**

NOTE: THIS TYPICAL DETAIL IS INTENDED TO PROVIDE DESIGN DIRECTION AND IS FOR REFERENCE ONLY. IT MAY BE USED AS PART OF THE CONSTRUCTION PACKAGE OR SITE PLAN APPLICATION PROVIDED THE DETAIL IS CERTIFIED BY A REGISTERED LANDSCAPE ARCHITECT OR PROFESSIONAL ENGINEER AS APPLICABLE.

DRAWN & DESIGNED: _____

STD. DWG. NO.

NOT TO SCALE DATE: _____

ULA 010

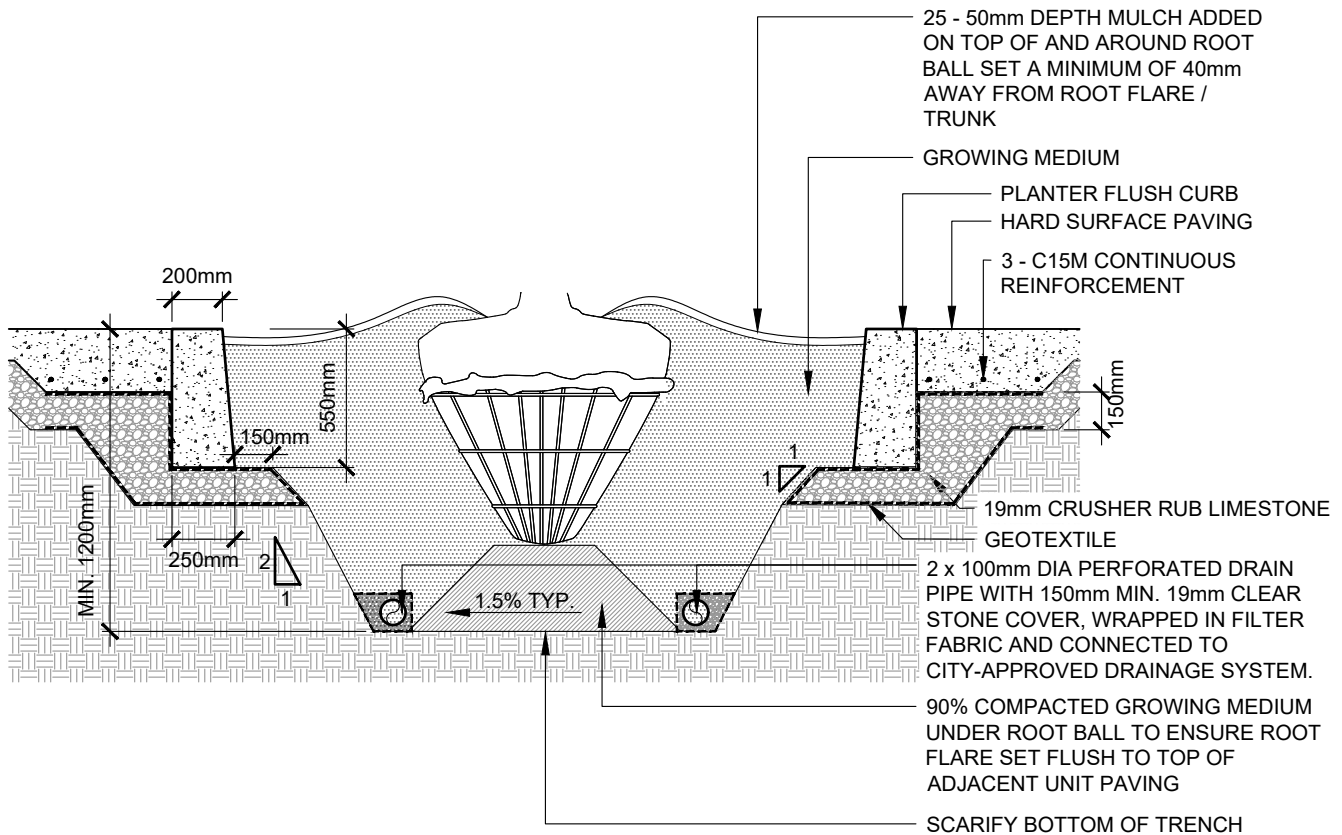

NOTES:

1. THIS TYPICAL DETAIL IS INTENDED TO CONVEY INTENT AND IS FOR REFERENCE ONLY. IT SHALL NOT BE USED AS PART OF THE CONSTRUCTION DRAWING PACKAGE OR SITE PLAN APPLICATION.
2. TREES SHALL HAVE ACCESS TO A MINIMUM OF 20 CUBIC METERS OF GROWING MEDIUM IN A SHARED TREE PIT OR 30 CUBIC METERS OF GROWING MEDIUM IN A STAND-ALONE TREE PIT.
3. REQUIRED SOIL VOLUMES MAY BE ACHIEVED USING ANY SOIL CELL PRODUCT.
4. ALL TREES MUST BE IRRIGATED. IRRIGATION IS TO BE DISTRIBUTED EVENLY THROUGHOUT TREE PIT. IRRIGATION MAY BE PASSIVE (UTILIZING STORMWATER) OR ACTIVE (UTILIZING AN IRRIGATION SYSTEM)
5. CONFIRM GRADING ON SITE. ALL PROPOSED GRADES TO MATCH EXISTING CONDITIONS.
6. DETAIL NOT TO BE USED UNLESS REVIEWED, STAMPED AND CERTIFIED BY REGISTERED LANDSCAPE ARCHITECT.



TREE - BED WITH FLUSH CURB

NOTE: THIS TYPICAL DETAIL IS INTENDED TO PROVIDE DESIGN DIRECTION AND IS FOR REFERENCE ONLY. IT MAY BE USED AS PART OF THE CONSTRUCTION PACKAGE OR SITE PLAN APPLICATION PROVIDED THE DETAIL IS CERTIFIED BY A REGISTERED LANDSCAPE ARCHITECT OR PROFESSIONAL ENGINEER AS APPLICABLE.

DRAWN & DESIGNED: _____
NOT TO SCALE DATE: _____

STD. DWG. NO.
ULA 011

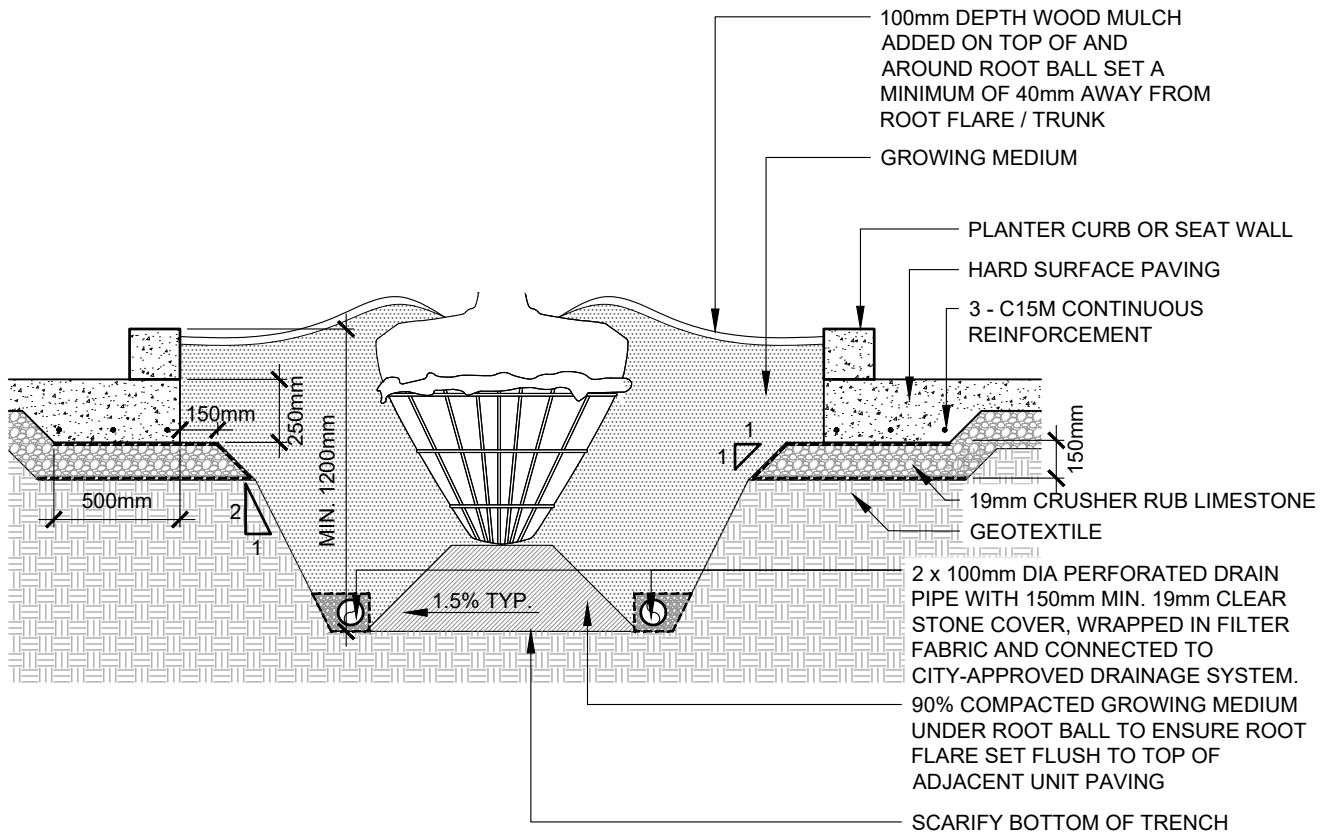

NOTES:

1. TREES SHALL HAVE ACCESS TO A MINIMUM OF 20 CUBIC METERS OF GROWING MEDIUM IN A SHARED TREE PIT OR 30 CUBIC METERS OF GROWING MEDIUM IN A STAND-ALONE TREE PIT.
2. REQUIRED SOIL VOLUMES MAY BE ACHIEVED USING ANY SOIL CELL PRODUCT.
3. ALL TREES MUST BE IRRIGATED. IRRIGATION IS TO BE DISTRIBUTED EVENLY THROUGHOUT TREE PIT. IRRIGATION MAY BE PASSIVE (UTILIZING STORMWATER) OR ACTIVE (UTILIZING AN IRRIGATION SYSTEM)
4. CONFIRM GRADING ON SITE. ALL PROPOSED GRADES TO MATCH EXISTING CONDITIONS.



VAUGHAN
DEVELOPMENT PLANNING DEPT.
URBAN DESIGN DIVISION

TREES - BED WITH CURB OR WALL

NOTE: THIS TYPICAL DETAIL IS INTENDED TO PROVIDE DESIGN DIRECTION AND IS FOR REFERENCE ONLY. IT MAY BE USED AS PART OF THE CONSTRUCTION PACKAGE OR SITE PLAN APPLICATION PROVIDED THE DETAIL IS CERTIFIED BY A REGISTERED LANDSCAPE ARCHITECT OR PROFESSIONAL ENGINEER AS APPLICABLE.

DRAWN & DESIGNED: _____
NOT TO SCALE DATE: _____

STD. DWG. NO.
ULA 012

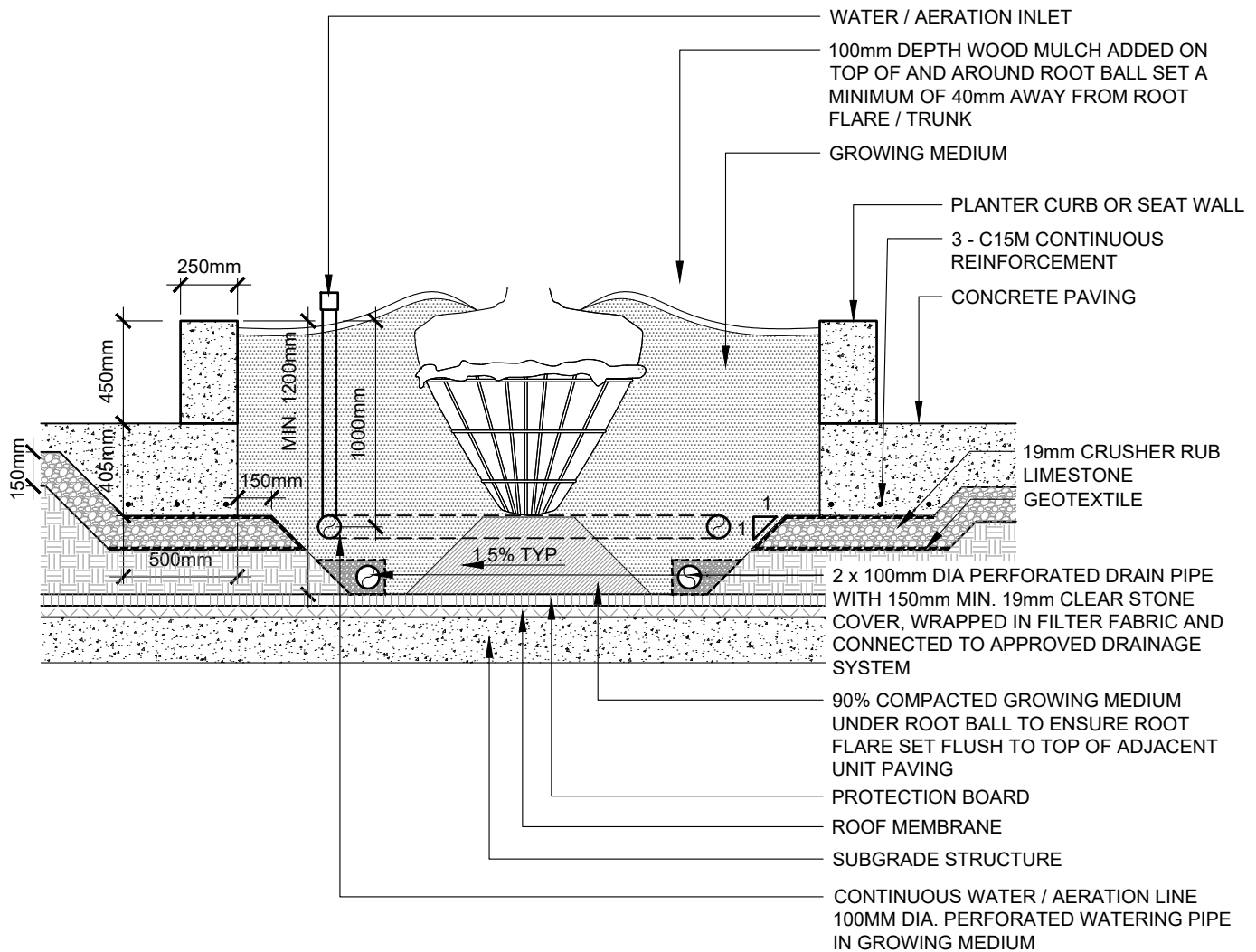

NOTES:

1. THIS TYPICAL DETAIL IS INTENDED TO CONVEY INTENT AND IS FOR REFERENCE ONLY. IT SHALL NOT BE USED AS PART OF THE CONSTRUCTION DRAWING PACKAGE OR SITE PLAN APPLICATION.
2. TREES SHALL HAVE ACCESS TO A MINIMUM OF 20 CUBIC METERS OF GROWING MEDIUM IN A SHARED TREE PIT OR 30 CUBIC METERS OF GROWING MEDIUM IN A STAND-ALONE TREE PIT.
3. REQUIRED SOIL VOLUMES MAY BE ACHIEVED USING ANY SOIL CELL PRODUCT.
4. ALL TREES MUST BE IRRIGATED. IRRIGATION IS TO BE DISTRIBUTED EVENLY THROUGHOUT TREE PIT. IRRIGATION MAY BE PASSIVE (UTILIZING STORMWATER) OR ACTIVE (UTILIZING AN IRRIGATION SYSTEM)
5. CONFIRM GRADING ON SITE. ALL PROPOSED GRADES TO MATCH EXISTING CONDITIONS.
6. DETAIL NOT TO BE USED UNLESS REVIEWED, STAMPED AND CERTIFIED BY REGISTERED LANDSCAPE ARCHITECT.

VAUGHAN
DEVELOPMENT PLANNING DEPT.
URBAN DESIGN DIVISION

TREES - BED ON STRUCTURAL SLAB

NOTE: THIS TYPICAL DETAIL IS INTENDED TO PROVIDE DESIGN DIRECTION AND IS FOR REFERENCE ONLY. IT MAY BE USED AS PART OF THE CONSTRUCTION PACKAGE OR SITE PLAN APPLICATION PROVIDED THE DETAIL IS CERTIFIED BY A REGISTERED LANDSCAPE ARCHITECT OR PROFESSIONAL ENGINEER AS APPLICABLE.

DRAWN & DESIGNED: _____
NOT TO SCALE DATE: _____

STD. DWG. NO.
ULA 013

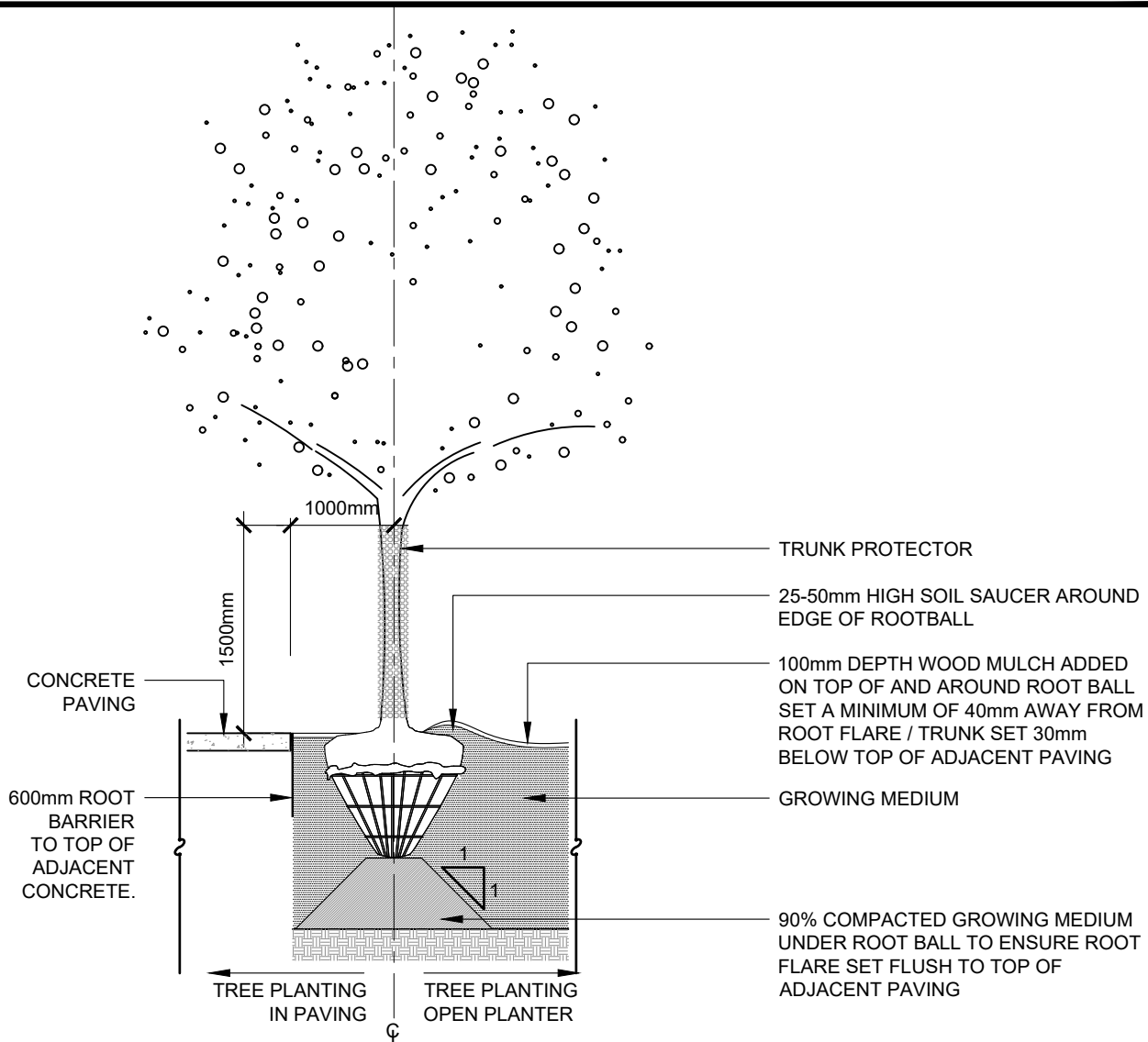

NOTES:

1. 2 TREES SHALL HAVE ACCESS TO A MINIMUM OF 20 CUBIC METERS OF GROWING MEDIUM IN A SHARED TREE PIT OR 30 CUBIC METERS OF GROWING MEDIUM IN A STAND-ALONE TREE PIT.
2. REMOVE ALL DEBRIS AND CONTAMINATED SOIL FROM PLANTING SPACE PRIOR TO PLANTING
3. DIG PLANTING HOLE TO THE DEPTH OF ROOT BALL SUCH THAT THE TRUNK FLARE IS FLUSH WITH PAVING ELEVATION
4. TREE WILL BE POSITIONED WITH TRUNK FLARE SLIGHTLY ABOVE FINAL GRADE AND TOP ROOTS NEAR THE SURFACE. TOP OF ROOT BALL SHOULD NOT BE DISTURBED OR COVERED WITH SOIL.
5. GROWING MEDIUM SHOULD BE LIGHTLY TAMPED ONCE HALF THE PLANTING HOLE IS FILLED. ONCE $\frac{2}{3}$ OF DEPTH OF PLANTING PIT HAS BEEN BACKFILLED, FILL REMAINING SPACE WITH WATER. ONCE WATER HAS PENETRATED GROWING MEDIUM, FILL TO FINISH GRADE. SOAK GROWING MEDIUM TO ENSURE FULL CONTACT BETWEEN ROOT BALL AND GROWING MEDIUM.
6. PRUNE TO REMOVE DAMAGED BRANCHES, DO NOT REMOVE LEADER. REMOVE ANY CO-DOMINANT STEMS.
7. REMOVE NURSERY TRUNK WRAP FROM TRUNK AND INSPECT FOR DAMAGE
8. IN ALL TREE OPENINGS (3.5 sq. m. OR SMALLER), INSTALL TREE BARK PROTECTOR.
9. AVOID STAKING BALLED OR BURLAPPED TREES.
10. ALL TREES MUST BE IRRIGATED. IRRIGATION IS TO BE DISTRIBUTED EVENLY THROUGHOUT TREE PIT. IRRIGATION MAY BE PASSIVE (UTILIZING STORMWATER) OR ACTIVE (UTILIZING AN IRRIGATION SYSTEM)
11. CONFIRM GRADING ON SITE. ALL PROPOSED GRADES TO MATCH EXISTING CONDITIONS.

VAUGHAN
DEVELOPMENT PLANNING DEPT.
URBAN DESIGN DIVISION

TYPICAL TREE PLANTING

NOTE: THIS TYPICAL DETAIL IS INTENDED TO PROVIDE DESIGN DIRECTION AND IS FOR REFERENCE ONLY. IT MAY BE USED AS PART OF THE CONSTRUCTION PACKAGE OR SITE PLAN APPLICATION PROVIDED THE DETAIL IS CERTIFIED BY A REGISTERED LANDSCAPE ARCHITECT OR PROFESSIONAL ENGINEER AS APPLICABLE.

DRAWN & DESIGNED: _____

STD. DWG. NO.

NOT TO SCALE DATE: _____

ULA 014

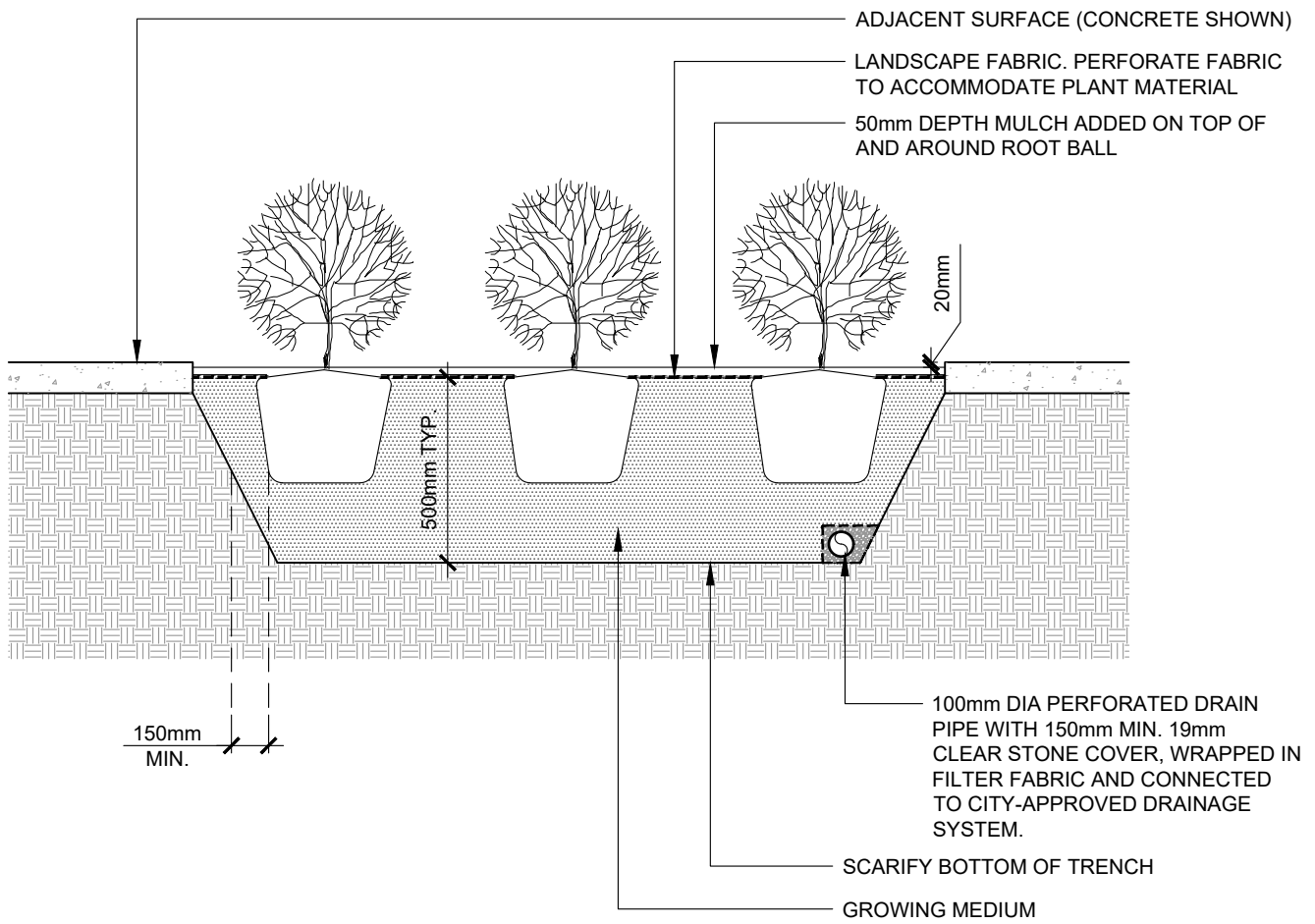

NOTES:

1. REMOVE TOP $\frac{1}{3}$ OF BURLAP FOR BURLAPPED PLANT MATERIAL
2. REMOVE CONTAINER AND SCARIFY EDGES TO MAINTAIN SOIL BALL FOR POTTED PLANT MATERIAL



VAUGHAN

DEVELOPMENT PLANNING DEPT.
URBAN DESIGN DIVISION

TYPICAL SHRUB PLANTING

NOTE: THIS TYPICAL DETAIL IS INTENDED TO PROVIDE DESIGN DIRECTION AND IS FOR REFERENCE ONLY. IT MAY BE USED AS PART OF THE CONSTRUCTION PACKAGE OR SITE PLAN APPLICATION PROVIDED THE DETAIL IS CERTIFIED BY A REGISTERED LANDSCAPE ARCHITECT OR PROFESSIONAL ENGINEER AS APPLICABLE.

DRAWN & DESIGNED: _____	STD. DWG. NO. _____
NOT TO SCALE DATE: _____	ULA 015

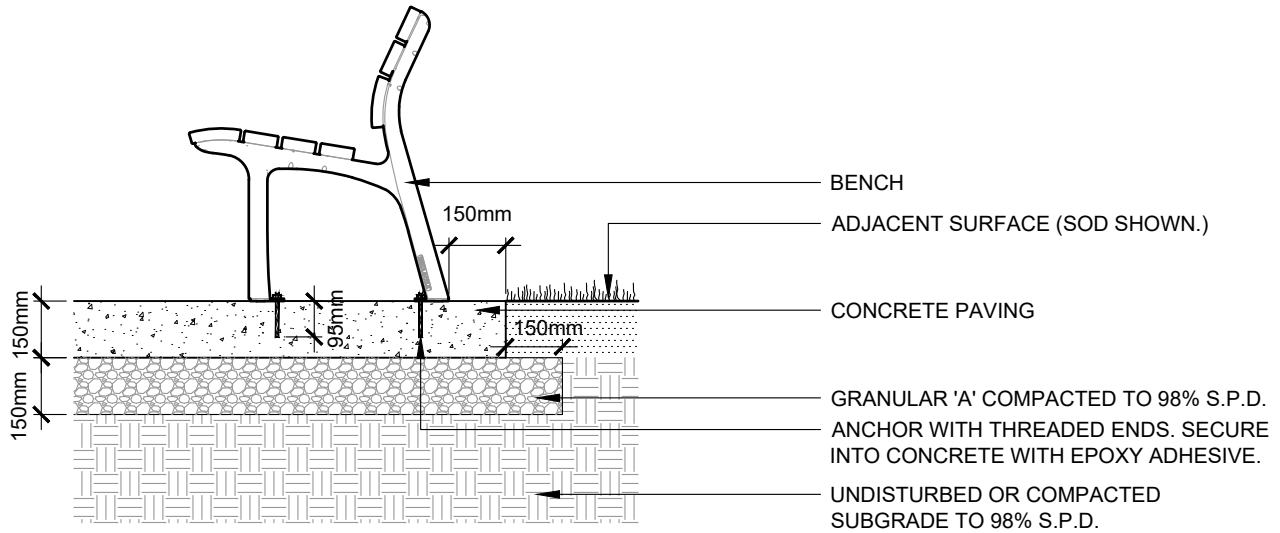

NOTES:

1. THIS TYPICAL DETAIL IS INTENDED TO CONVEY INTENT AND IS FOR REFERENCE ONLY. IT SHALL NOT BE USED AS PART OF THE CONSTRUCTION DRAWING PACKAGE OR SITE PLAN APPLICATION.
2. BENCH: NEOLIVIANO BY LANDSCAPE FORMS. ALUMINUM FINISH WITH JARAH WOOD OR APPROVED EQUIVALENT.
3. INSTALLATION PER MANUFACTURER'S WRITTEN INSTRUCTIONS

	<h1 style="margin: 0;">VAUGHAN</h1> <p style="margin: 0;">DEVELOPMENT PLANNING DEPT. URBAN DESIGN DIVISION</p>
<h2 style="margin: 0;">FURNISHING - BENCH</h2>	
<p>NOTE: THIS TYPICAL DETAIL IS INTENDED TO PROVIDE DESIGN DIRECTION AND IS FOR REFERENCE ONLY. IT MAY BE USED AS PART OF THE CONSTRUCTION PACKAGE OR SITE PLAN APPLICATION PROVIDED THE DETAIL IS CERTIFIED BY A REGISTERED LANDSCAPE ARCHITECT OR PROFESSIONAL ENGINEER AS APPLICABLE.</p>	
DRAWN & DESIGNED: _____ NOT TO SCALE DATE: _____	STD. DWG. NO. ULA 016

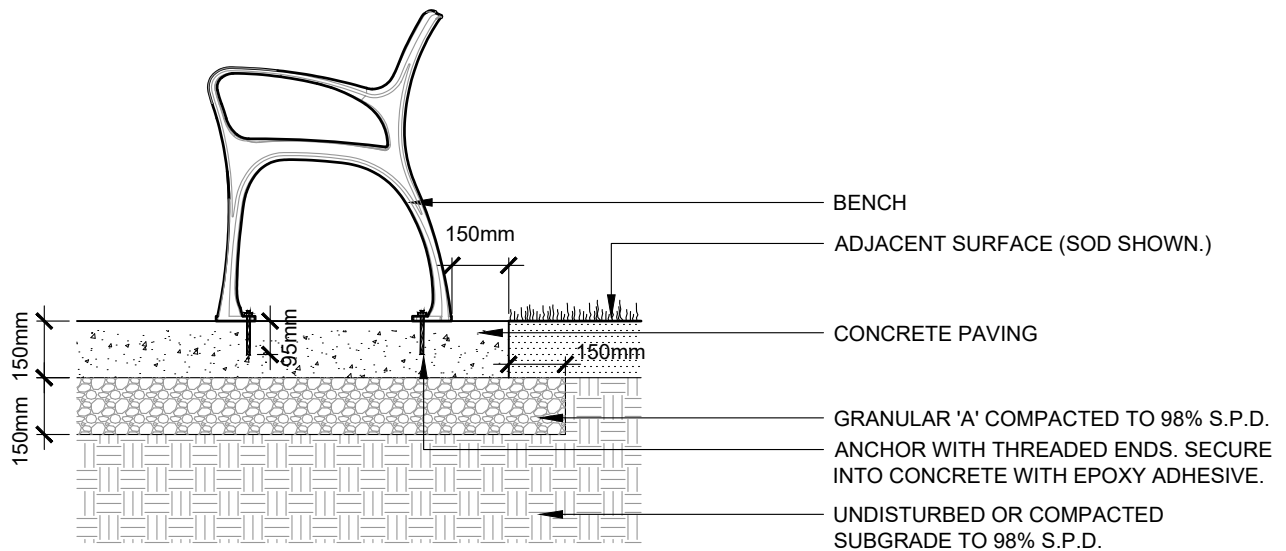

NOTES:

1. BENCH: MLB870W BY MAGLIN FURNITURE INC. SOLID CAST ALUMINUM FINISH WITH IPE WOOD OR APPROVED EQUIVALENT. COLOUR TO BE SPECIFIED BY LANDSCAPE ARCHITECT.
2. INSTALLATION PER MANUFACTURER'S WRITTEN INSTRUCTIONS



VAUGHAN
 DEVELOPMENT PLANNING DEPT.
 URBAN DESIGN DIVISION

FURNISHING - BENCH

NOTE: THIS TYPICAL DETAIL IS INTENDED TO PROVIDE DESIGN DIRECTION AND IS FOR REFERENCE ONLY. IT MAY BE USED AS PART OF THE CONSTRUCTION PACKAGE OR SITE PLAN APPLICATION PROVIDED THE DETAIL IS CERTIFIED BY A REGISTERED LANDSCAPE ARCHITECT OR PROFESSIONAL ENGINEER AS APPLICABLE.

DRAWN & DESIGNED: _____
 NOT TO SCALE DATE: _____

STD. DWG. NO.
ULA 017

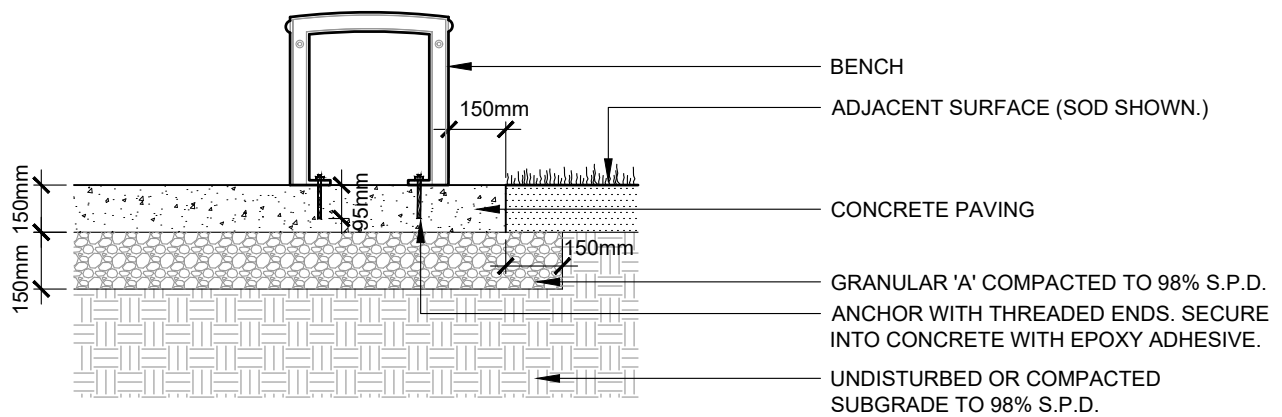

NOTES:

1. BENCH: MLB720BW BACKLESS BENCH BY MAGLIN FURNITURE INC. SOLID CAST ALUMINUM FINISH WITH IPE WOOD OR APPROVED EQUIVALENT. COLOUR TO BE SPECIFIED BY LANDSCAPE ARCHITECT.
2. INSTALLATION PER MANUFACTURER'S WRITTEN INSTRUCTIONS



VAUGHAN
 DEVELOPMENT PLANNING DEPT.
 URBAN DESIGN DIVISION

FURNISHING - BENCH

NOTE: THIS TYPICAL DETAIL IS INTENDED TO PROVIDE DESIGN DIRECTION AND IS FOR REFERENCE ONLY. IT MAY BE USED AS PART OF THE CONSTRUCTION PACKAGE OR SITE PLAN APPLICATION PROVIDED THE DETAIL IS CERTIFIED BY A REGISTERED LANDSCAPE ARCHITECT OR PROFESSIONAL ENGINEER AS APPLICABLE.

DRAWN & DESIGNED: _____

STD. DWG. NO.

NOT TO SCALE DATE: _____

ULA 018

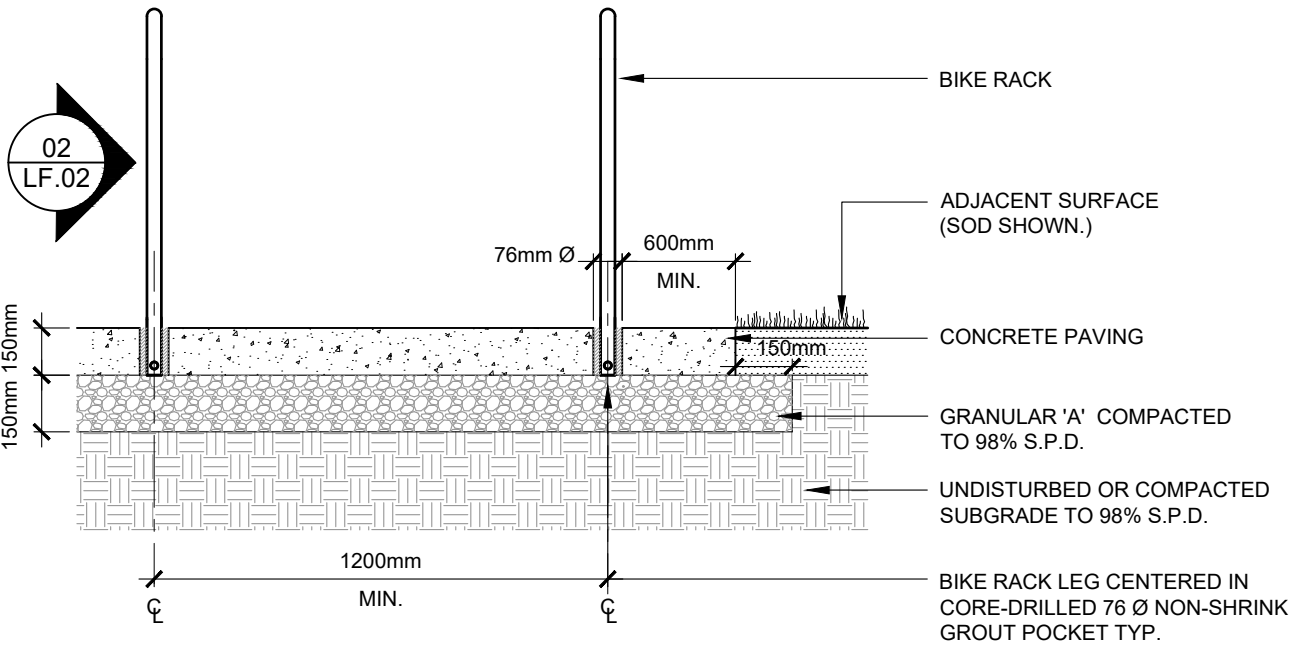

01: TYPICAL BIKE RACK MOUNTING SECTION-ELEVATION 'A'

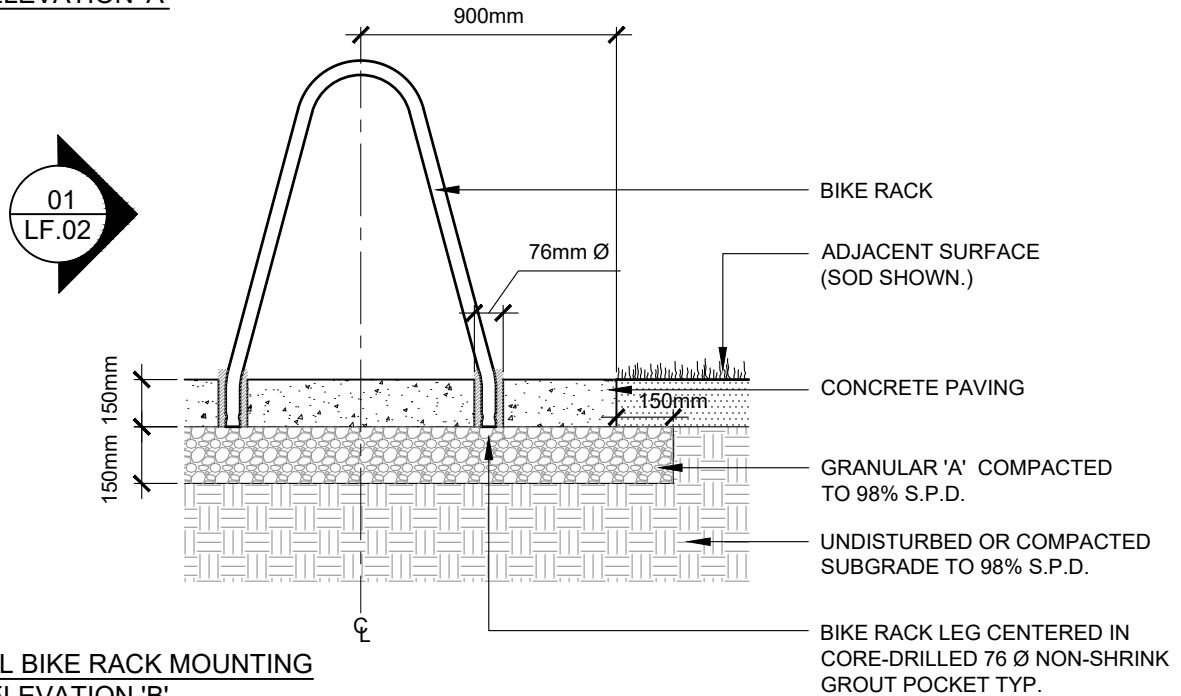

02: TYPICAL BIKE RACK MOUNTING SECTION-ELEVATION 'B'

NOTES:

1. BIKE RACK: BOLA BY LANDSCAPE FORMS, STAINLESS STEEL OR APPROVED EQUIVALENT.
2. INSTALLATION PER MANUFACTURER'S WRITTEN INSTRUCTIONS
3. REFER TO SPECIFICATIONS FOR GROUT POCKET MATERIAL
4. DETAIL NOT TO BE USED UNLESS REVIEWED, STAMPED AND CERTIFIED BY REGISTERED LANDSCAPE ARCHITECT.
5. PROVIDE A MINIMUM OF 600mm X 1800mm CLEAR SPACE EITHER SIDE OF BICYCLE RACK FOR PARKING.

VAUGHAN
DEVELOPMENT PLANNING DEPT.
URBAN DESIGN DIVISION

FURNISHING - BICYCLE RACK

NOTE: THIS TYPICAL DETAIL IS INTENDED TO PROVIDE DESIGN DIRECTION AND IS FOR REFERENCE ONLY. IT MAY BE USED AS PART OF THE CONSTRUCTION PACKAGE OR SITE PLAN APPLICATION PROVIDED THE DETAIL IS CERTIFIED BY A REGISTERED LANDSCAPE ARCHITECT OR PROFESSIONAL ENGINEER AS APPLICABLE.

DRAWN & DESIGNED: _____

STD. DWG. NO.

NOT TO SCALE DATE: _____

ULA 019

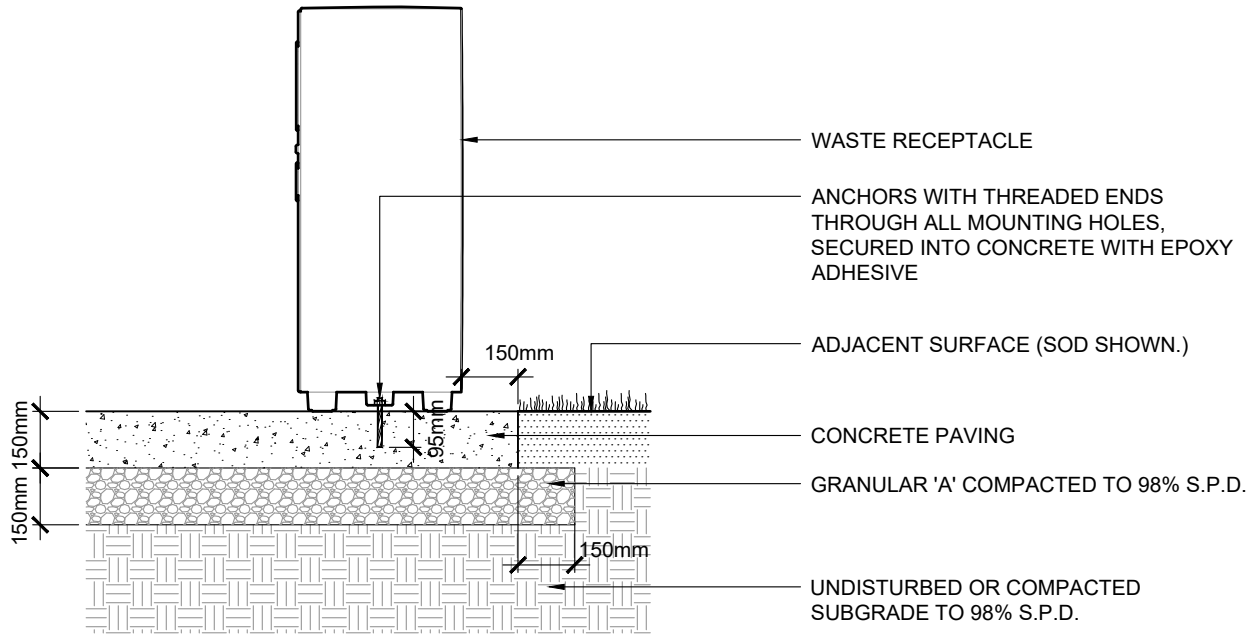

NOTES:

1. THIS TYPICAL DETAIL IS INTENDED TO CONVEY INTENT AND IS FOR REFERENCE ONLY. IT SHALL NOT BE USED AS PART OF THE CONSTRUCTION DRAWING PACKAGE OR SITE PLAN APPLICATION.
2. WASTE RECEPTACLE: SELECT LITTER RECEPTACLE BY LANDSCAPE FORMS, TRIPLE UNIT, SOLID BODY, PERFORATED DOORS. COLOURS - POWDERCOATED SILVER, BLACK FOR TRIM RING AND SIGNAGE PLATE, OR APPROVED EQUIVALENT.
3. INSTALLATION PER MANUFACTURER'S WRITTEN INSTRUCTIONS
4. DETAIL NOT TO BE USED UNLESS REVIEWED, STAMPED AND CERTIFIED BY REGISTERED LANDSCAPE ARCHITECT.



VAUGHAN
DEVELOPMENT PLANNING DEPT.
URBAN DESIGN DIVISION

FURNISHING - WASTE RECEPTACLE

NOTE: THIS TYPICAL DETAIL IS INTENDED TO PROVIDE DESIGN DIRECTION AND IS FOR REFERENCE ONLY. IT MAY BE USED AS PART OF THE CONSTRUCTION PACKAGE OR SITE PLAN APPLICATION PROVIDED THE DETAIL IS CERTIFIED BY A REGISTERED LANDSCAPE ARCHITECT OR PROFESSIONAL ENGINEER AS APPLICABLE.

DRAWN & DESIGNED: _____

STD. DWG. NO.

NOT TO SCALE DATE: _____

ULA 020

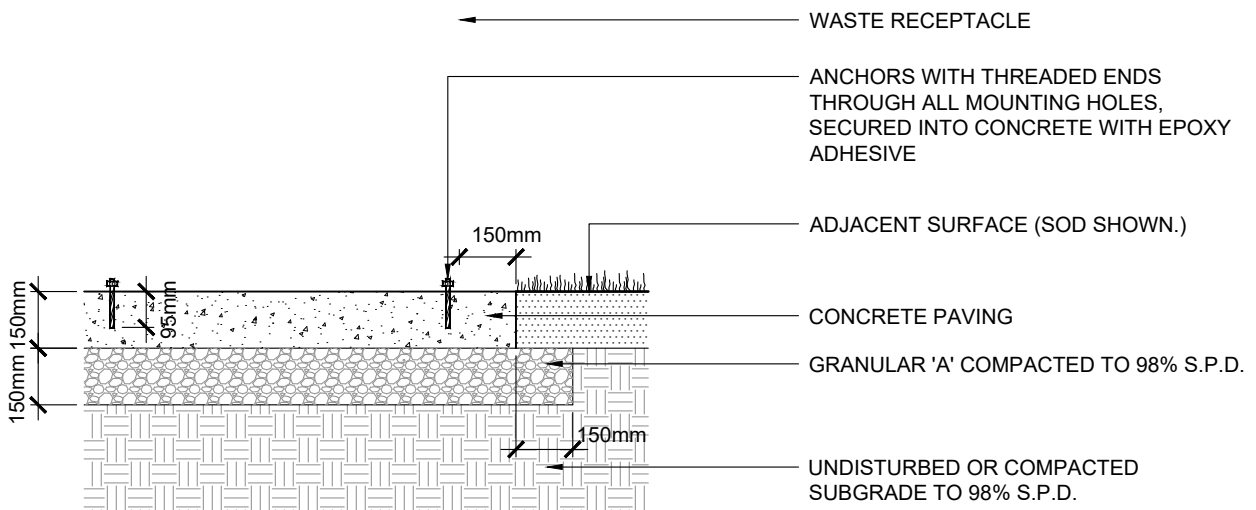
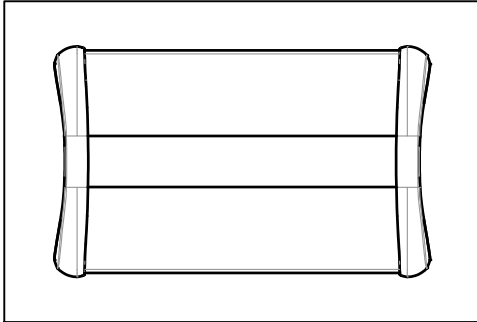

NOTES:

1. THIS TYPICAL DETAIL IS INTENDED TO CONVEY INTENT AND IS FOR REFERENCE ONLY. IT SHALL NOT BE USED AS PART OF THE CONSTRUCTION DRAWING PACKAGE OR SITE PLAN APPLICATION.
2. WASTE RECEPTACLE: MRC1403 RECYCLE UNIT BY BY MAGLIN FURNITURE INC., 95% RECYCLED ALUMINUM FRAME, SUSTAINABLE COMPONENTS SUCH AS HDPE PLASTIC OR STEEL FOR SIDE AND DOOR PANELS, BLACK FOR FACE PLATE, 3-23 GALLON CAPACITY COMPARTMENTS, STAINLESS STEEL LID OR APPROVED EQUIVALENT.
3. INSTALLATION PER MANUFACTURER'S WRITTEN INSTRUCTIONS



FURNISHING - WASTE RECEPTACLE

NOTE: THIS TYPICAL DETAIL IS INTENDED TO PROVIDE DESIGN DIRECTION AND IS FOR REFERENCE ONLY. IT MAY BE USED AS PART OF THE CONSTRUCTION PACKAGE OR SITE PLAN APPLICATION PROVIDED THE DETAIL IS CERTIFIED BY A REGISTERED LANDSCAPE ARCHITECT OR PROFESSIONAL ENGINEER AS APPLICABLE.

DRAWN & DESIGNED: _____

STD. DWG. NO.

NOT TO SCALE DATE: _____

ULA 021

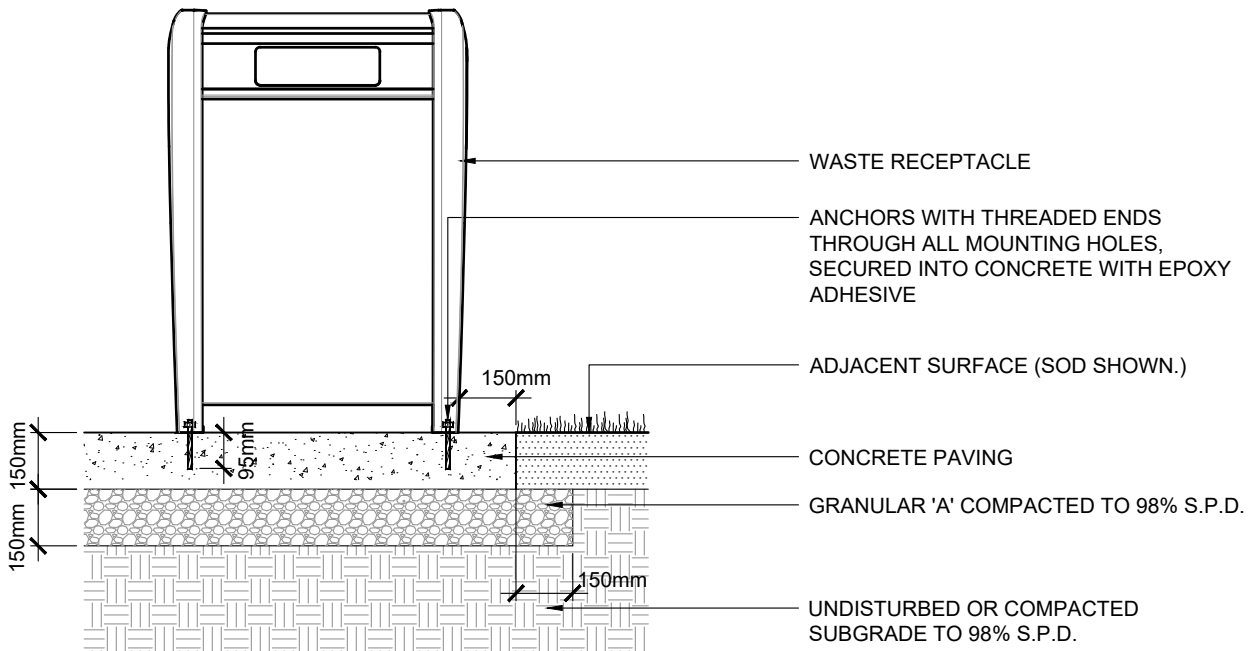
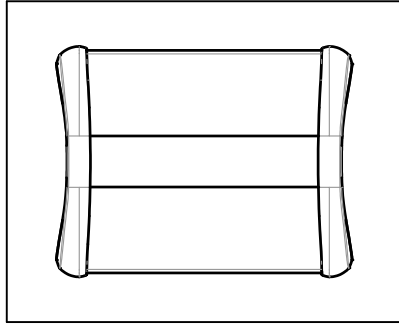

NOTES:

1. THIS TYPICAL DETAIL IS INTENDED TO CONVEY INTENT AND IS FOR REFERENCE ONLY. IT SHALL NOT BE USED AS PART OF THE CONSTRUCTION DRAWING PACKAGE OR SITE PLAN APPLICATION.
2. WASTE RECEPTACLE: MRC1400-32 RECYCLE UNIT BY BY MAGLIN FURNITURE INC., 95% RECYCLED ALUMINUM FRAME, SUSTAINABLE COMPONENTS SUCH AS HDPE PLASTIC OR STEEL FOR SIDE AND DOOR PANELS, BLACK FOR FACE PLATE, A 32 GALLON CAPACITY COMPARTMENTS, STAINLESS STEEL LID OR APPROVED EQUIVALENT.
3. INSTALLATION PER MANUFACTURER'S WRITTEN INSTRUCTIONS



FURNISHING - WASTE RECEPTACLE

NOTE: THIS TYPICAL DETAIL IS INTENDED TO PROVIDE DESIGN DIRECTION AND IS FOR REFERENCE ONLY. IT MAY BE USED AS PART OF THE CONSTRUCTION PACKAGE OR SITE PLAN APPLICATION PROVIDED THE DETAIL IS CERTIFIED BY A REGISTERED LANDSCAPE ARCHITECT OR PROFESSIONAL ENGINEER AS APPLICABLE.

DRAWN & DESIGNED: _____
 NOT TO SCALE DATE: _____

STD. DWG. NO.
ULA 022

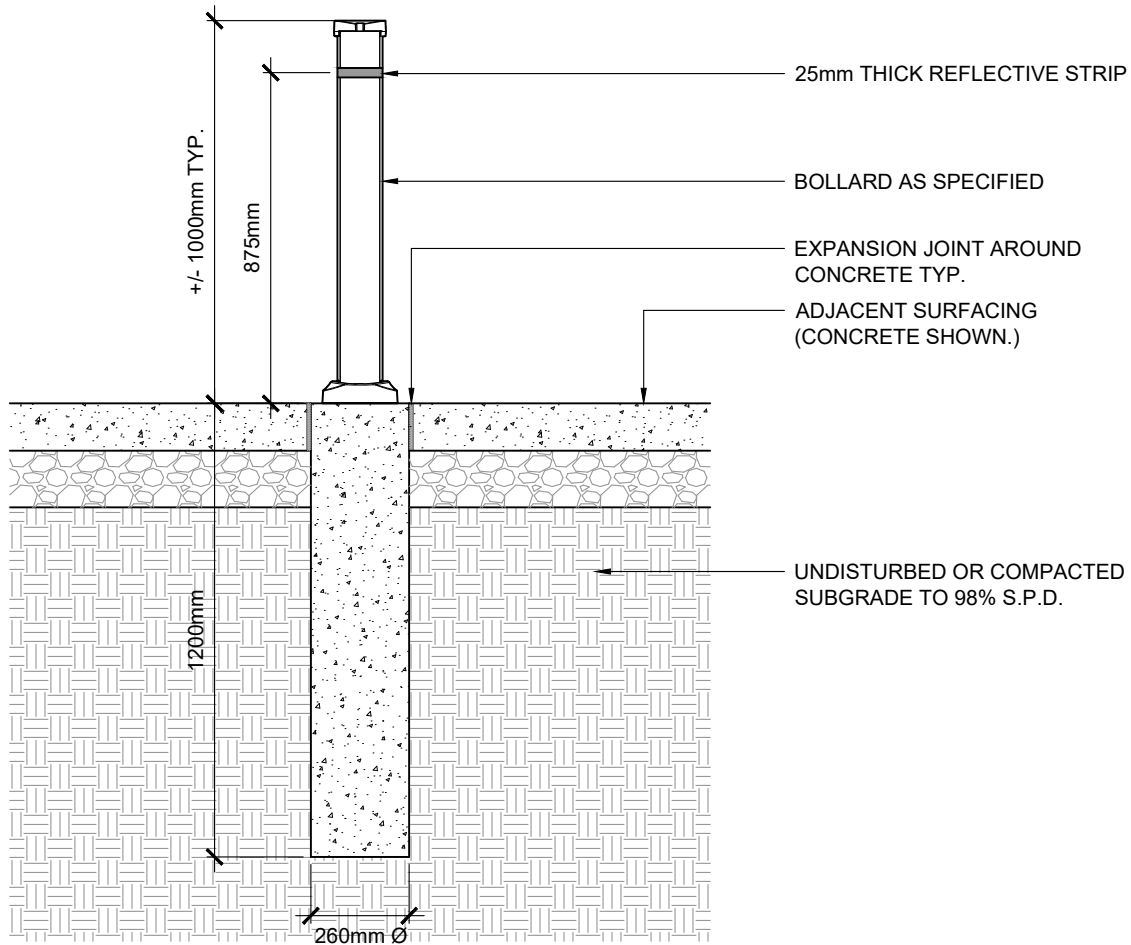

NOTES:

1. THIS TYPICAL DETAIL IS INTENDED TO CONVEY INTENT AND IS FOR REFERENCE ONLY. IT SHALL NOT BE USED AS PART OF THE CONSTRUCTION DRAWING PACKAGE OR SITE PLAN APPLICATION.
2. BOLLARD MAKE AND MODEL AS SPECIFIED
3. INSTALL BOLLARD PER MANUFACTURER'S WRITTEN INSTRUCTIONS
4. DETAIL NOT TO BE USED UNLESS REVIEWED, STAMPED AND CERTIFIED BY REGISTERED LANDSCAPE ARCHITECT.



VAUGHAN
 DEVELOPMENT PLANNING DEPT.
 URBAN DESIGN DIVISION

FURNISHING - BOLLARD

NOTE: THIS TYPICAL DETAIL IS INTENDED TO PROVIDE DESIGN DIRECTION AND IS FOR REFERENCE ONLY. IT MAY BE USED AS PART OF THE CONSTRUCTION PACKAGE OR SITE PLAN APPLICATION PROVIDED THE DETAIL IS CERTIFIED BY A REGISTERED LANDSCAPE ARCHITECT OR PROFESSIONAL ENGINEER AS APPLICABLE.

DRAWN & DESIGNED: _____

STD. DWG. NO.

NOT TO SCALE DATE: _____

ULA 023

02:

URBAN DESIGN STANDARD DETAILS

NOTE:
ALL TREES NOT MEETING CITY OF VAUGHAN REQUIREMENTS WILL BE REMOVED AND REPLACED AT NO EXPENSE TO THE CITY.

AT GRADE

100mm WOOD MULCH

1800mm MIN. BRANCHING HEIGHT

100mm

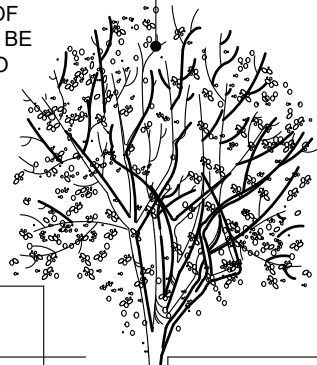

DO NOT DAMAGE OR CUT LEADER BRANCH
PRUNE DOMINANT LATERAL BRANCHES

TWO PLY REINFORCED RUBBER HOSE

2 - 2" x 2" WOOD STEAKS SECURED WITH #4 ALUMINUM WIRE; LOCATE STAKES AWAY FROM THE TRUNK, ONE ON SIDE OF PREVAILING WIND, THE OTHER AT THE OPPOSITE SIDE (FOR TREES 75mm IN CALIPER OR LESS) ANGLE STAKES 5 - 15 DEGREES

DRAIN PIPE 100mm DIA.; 450mm PLASTIC CORRUGATED

150mm SPACE

CROWN OF ROOT BALL

SOD

FINISH GRADE

CLEAN SHARP EDGE BETWEEN SAUCER AND SOD / SEED

CREATE SAUCER AROUND TREE

AERATE AND SCARIFY SOIL SURROUNDING PLANTING PIT AND BASE OF PIT

APPROVED SOIL MIXTURE

CUT AND REMOVE TOP 1/3 OF BURLAP; REMOVE ALL SIDES OF WIRE BASKET AND ALL TIES

SUBGRADE

EXCAVATE 100mm DEPTH FOR MOUNDING INTO EXISTING SUBSOIL

CREATE SAUCER AROUND TREE

APPROVED SOIL MIXTURE

FINISH GRADE

VARIES WITH SLOPE

SLOPE PIT BOTTOM FOR DRAINAGE

SUBGRADE

ON A SLOPE

100mm

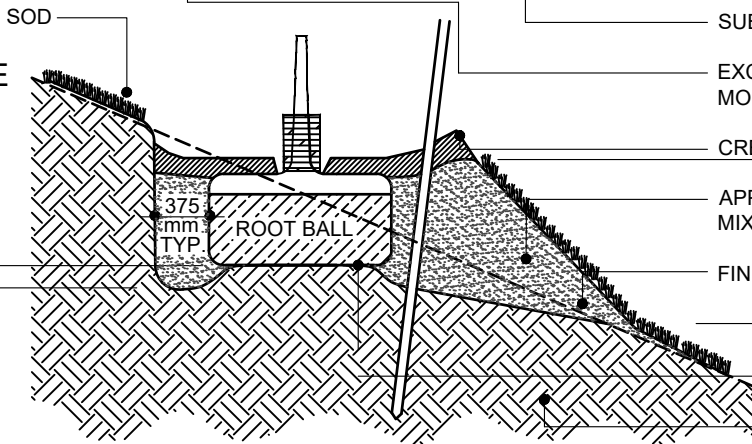

NOTES:

1. Position crown of root ball 50mm above finish grade to allow for settling.
2. Do corrective pruning to retain natural form of tree as directed by City Forestry Supervisor.
3. Water all plant material sufficiently to maintain vigorous, healthy growth from time of delivery/ installation until the end of the specified guarantee period.
4. Stake height shall be a minimum of 1.5 metres above finish grade.
5. For trees planted within planting or shrub beds, delete saucer around base of tree.
6. Remove all tree guards/ stakes 12 months after acceptance/ assumption or as specified.
7. No tree pits shall be left open overnight.
8. Do not allow air pockets when backfilling.
9. All dimensions are in millimeters.

VAUGHAN
DEVELOPMENT PLANNING DEPT.
URBAN DESIGN DIVISION

**DECIDUOUS TREE
PLANTING DETAIL FOR
TREES UNDER 90mm IN CALIPER**

NOTE: THIS TYPICAL DETAIL IS INTENDED TO PROVIDE DESIGN DIRECTION AND IS FOR REFERENCE ONLY. IT MAY BE USED AS PART OF THE CONSTRUCTION PACKAGE OR SITE PLAN APPLICATION PROVIDED THE DETAIL IS CERTIFIED BY A REGISTERED LANDSCAPE ARCHITECT OR PROFESSIONAL ENGINEER AS APPLICABLE.

DRAWN & DESIGNED: URBAN DESIGN
NOT TO SCALE DATE: 03/01/2011

STD. DWG. NO. ULA 101

NOTE:
ALL TREES NOT MEETING CITY OF VAUGHAN REQUIREMENTS WILL BE REMOVED AND REPLACED AT NO EXPENSE TO THE CITY.

TURNBUCKLE (TO BE PAINTED WITH FLUORESCENT PAINT AND FLAGGED)

100mm WOOD MULCH

ANCHOR (TO BE PAINTED WITH FLUORESCENT PAINT)

1800mm MIN. BRANCHING HEIGHT

100mm

AT GRADE

SOD

100mm

ON A SLOPE

NOTES:

1. Position crown of root ball 50mm above finish grade to allow for settling.
2. Do corrective pruning to retain natural form of tree as directed by City Forestry Supervisor.
3. Water all plant material sufficiently to maintain vigorous, healthy growth from time of delivery/ installation until the end of the specified guarantee period.
4. Stake height shall be a minimum of 1.5 metres above finish grade.
5. For trees planted within planting or shrub beds, delete saucer around base of tree.
6. Remove all tree guards/ stakes 12 months after acceptance/ assumption or as specified.
7. No tree pits shall be left open overnight.
8. Do not allow air pockets when backfilling.
9. All dimensions are in millimeters.

DO NOT DAMAGE OR CUT LEADER BRANCH
PRUNE DOMINANT LATERAL BRANCHES

3 GUY WIRES PER TREE AT 120 DEGREE INTERVALS; WIRE ENCASED IN RUBBER HOSE; LOCATE GUY WIRES ABOVE LIMB TO PREVENT SLIPPING DOWN (FOR TREES OVER 75mm IN CALIPER)

DRAIN PIPE 100mm DIA.; 450mm PLASTIC CORRUGATED

150mm SPACE

CROWN OF ROOT BALL

SOD

FINISH GRADE

CLEAN SHARP EDGE BETWEEN SAUCER AND SOD / SEED

CREATE SAUCER AROUND TREE

AERATE AND SCARIFY SOIL SURROUNDING PLANTING PIT

APPROVED SOIL MIXTURE

CUT AND REMOVE TOP 1/3 OF BURLAP; REMOVE ALL SIDES OF WIRE BASKET AND ALL TIES

SUBGRADE

EXCAVATE 100mm DEPTH FOR MOUNDING INTO EXISTING SUBSOIL

CREATE SAUCER AROUND TREE

APPROVED SOIL MIXTURE

FINISH GRADE

VARIES WITH SLOPE

SLOPE PIT BOTTOM FOR DRAINAGE

SUBGRADE



VAUGHAN
DEVELOPMENT PLANNING DEPT.
URBAN DESIGN DIVISION

DECIDUOUS TREE
PLANTING DETAIL FOR
TREES OVER 90mm IN CALIPER

NOTE: THIS TYPICAL DETAIL IS INTENDED TO PROVIDE DESIGN DIRECTION AND IS FOR REFERENCE ONLY. IT MAY BE USED AS PART OF THE CONSTRUCTION PACKAGE OR SITE PLAN APPLICATION PROVIDED THE DETAIL IS CERTIFIED BY A REGISTERED LANDSCAPE ARCHITECT OR PROFESSIONAL ENGINEER AS APPLICABLE.

DRAWN & DESIGNED: URBAN DESIGN

STD. DWG. NO.

NOT TO SCALE DATE: 03/01/2011

ULA 102

NOTE:
ALL TREES NOT MEETING CITY OF VAUGHAN REQUIREMENTS WILL BE REMOVED AND REPLACED AT NO EXPENSE TO THE CITY.

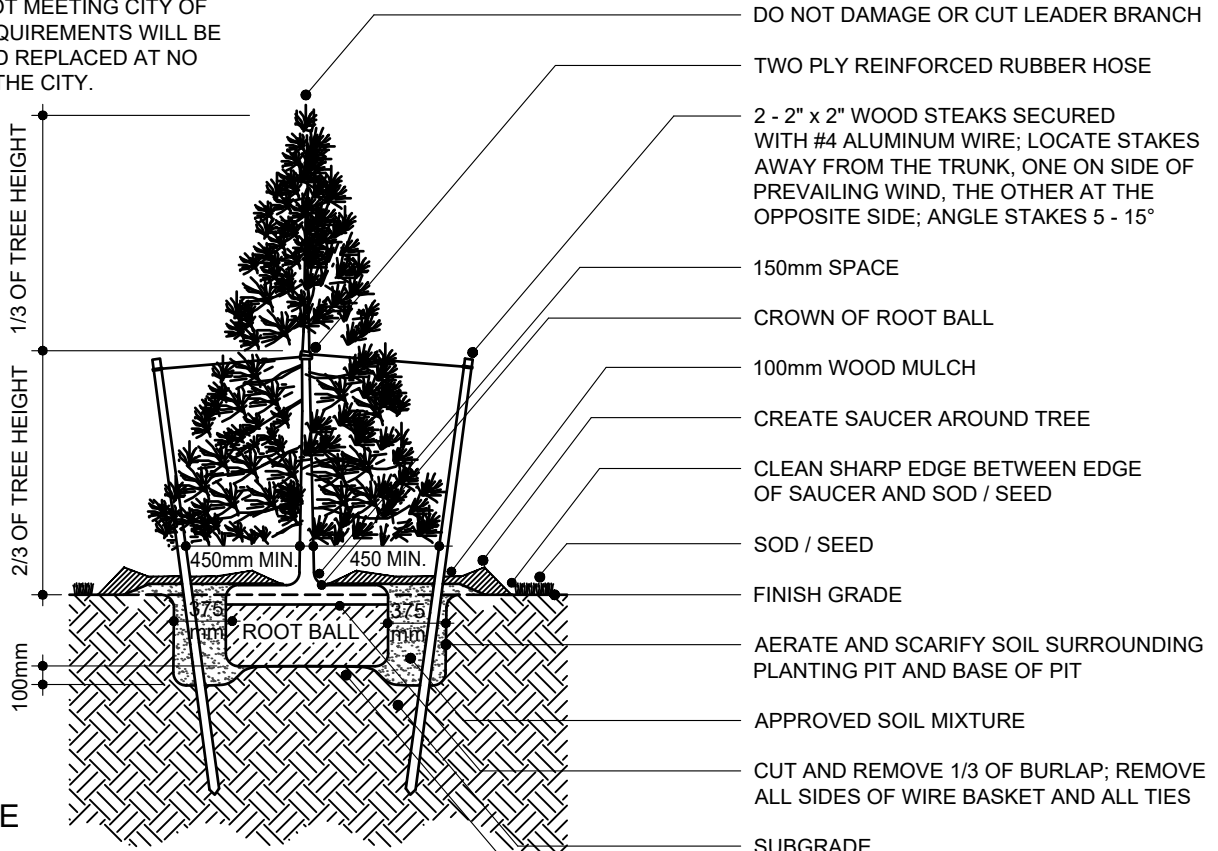

AT GRADE

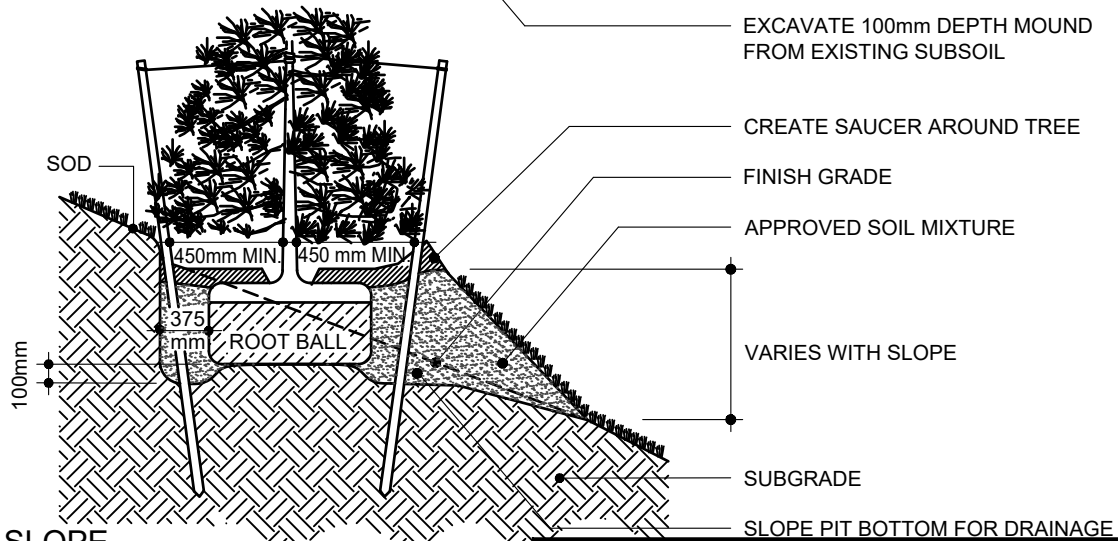

ON A SLOPE

NOTES:

1. All dimensions are in millimeters.
2. No tree pits shall be left open overnight.
3. Do not allow air pockets when backfilling.
4. Position crown of root ball 50mm above finish grade to allow for settling.
5. Water all plant material sufficiently to maintain vigorous, healthy growth from time of delivery/ installation until the end of the specified guarantee period.
6. For trees planted within planting or shrub beds, delete saucer around base of tree.
7. Remove all tree guards/ stakes 12 months after acceptance/ assumption or as specified.



VAUGHAN
DEVELOPMENT PLANNING DEPT.
URBAN DESIGN DIVISION

CONIFEROUS TREE
PLANTING DETAIL FOR
TREES 2500mm IN HEIGHT OR LESS

NOTE: THIS TYPICAL DETAIL IS INTENDED TO PROVIDE DESIGN DIRECTION AND IS FOR REFERENCE ONLY. IT MAY BE USED AS PART OF THE CONSTRUCTION PACKAGE OR SITE PLAN APPLICATION PROVIDED THE DETAIL IS CERTIFIED BY A REGISTERED LANDSCAPE ARCHITECT OR PROFESSIONAL ENGINEER AS APPLICABLE.

DRAWN & DESIGNED: URBAN DESIGN

STD. DWG. NO.

NOT TO SCALE DATE: 03 / 01 / 2011

ULA 103

NOTE:
ALL TREES NOT MEETING CITY OF VAUGHAN REQUIREMENTS WILL BE REMOVED AND REPLACED AT NO EXPENSE TO THE CITY.

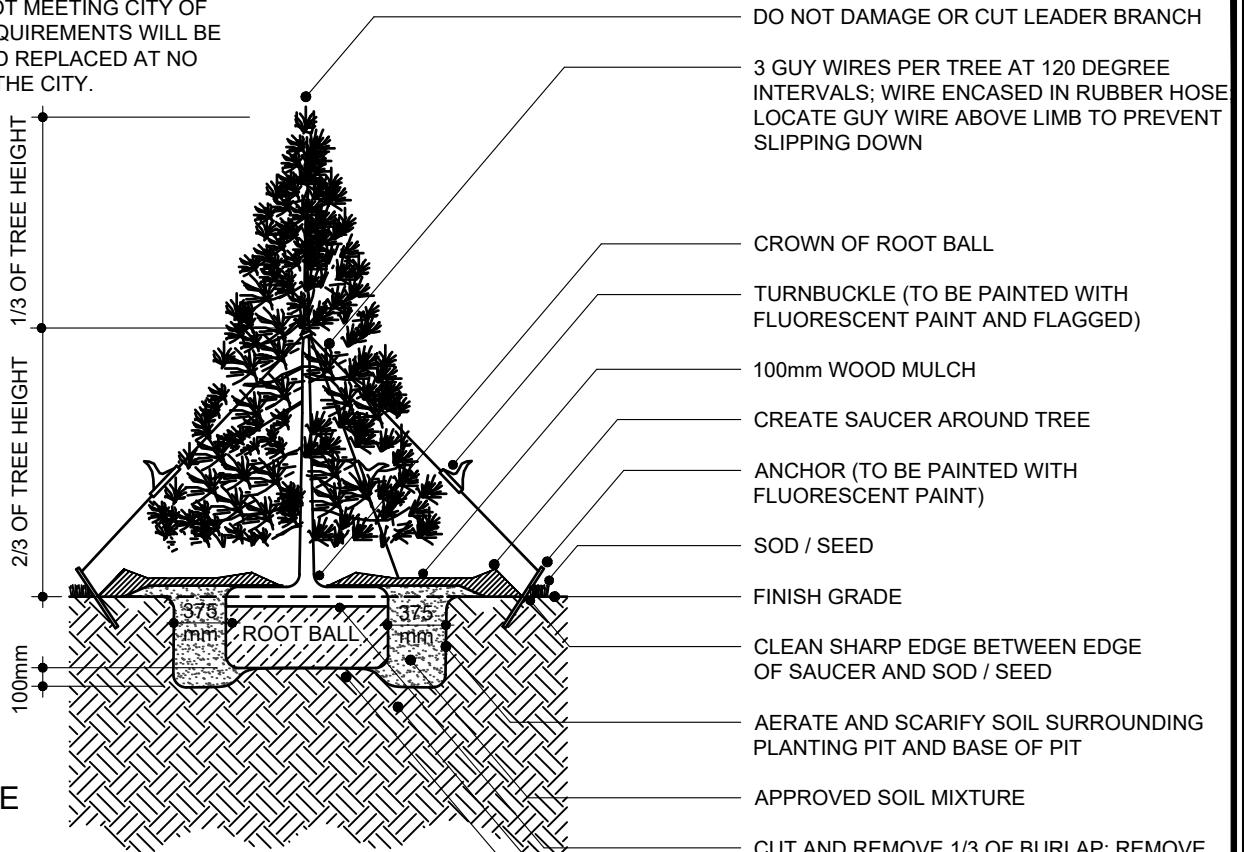

AT GRADE

NOTE:
FOR TREES WITH ROOT BALLS LARGER THAN 900mm REFER TO SPECIFICATIONS FOR TREE PIT SIZE.

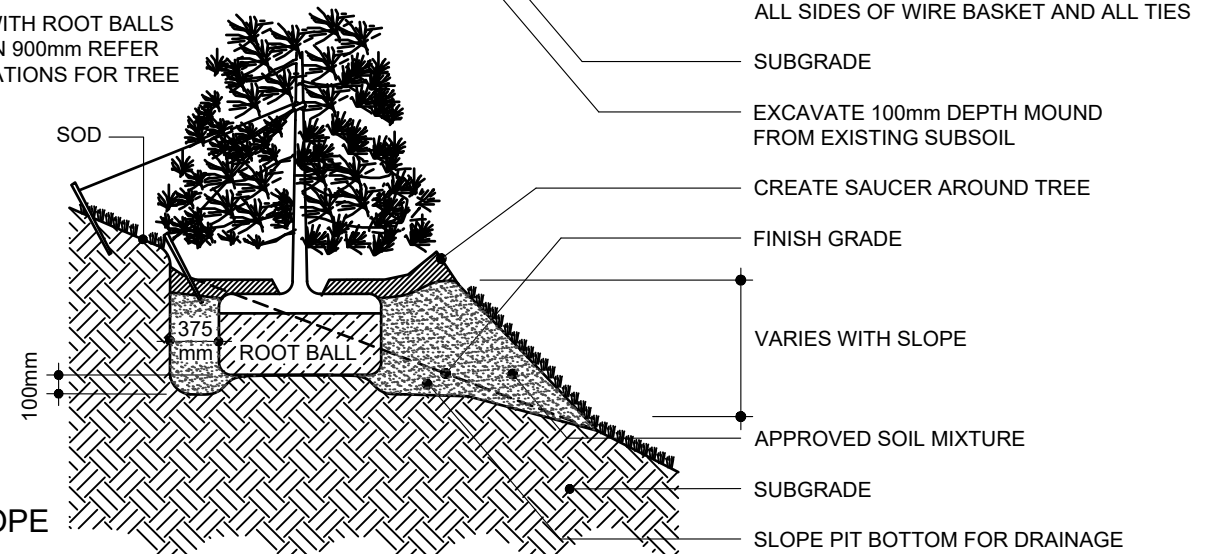

ON A SLOPE

- DO NOT DAMAGE OR CUT LEADER BRANCH
- 3 GUY WIRES PER TREE AT 120 DEGREE INTERVALS; WIRE ENCASED IN RUBBER HOSE LOCATE GUY WIRE ABOVE LIMB TO PREVENT SLIPPING DOWN
- CROWN OF ROOT BALL
- TURNBUCKLE (TO BE PAINTED WITH FLUORESCENT PAINT AND FLAGGED)
- 100mm WOOD MULCH
- CREATE SAUCER AROUND TREE
- ANCHOR (TO BE PAINTED WITH FLUORESCENT PAINT)
- SOD / SEED
- FINISH GRADE
- CLEAN SHARP EDGE BETWEEN EDGE OF SAUCER AND SOD / SEED
- AERATE AND SCARIFY SOIL SURROUNDING PLANTING PIT AND BASE OF PIT
- APPROVED SOIL MIXTURE
- CUT AND REMOVE 1/3 OF BURLAP; REMOVE ALL SIDES OF WIRE BASKET AND ALL TIES
- SUBGRADE
- EXCAVATE 100mm DEPTH MOUND FROM EXISTING SUBSOIL
- CREATE SAUCER AROUND TREE
- FINISH GRADE
- VARIES WITH SLOPE
- APPROVED SOIL MIXTURE
- SUBGRADE
- SLOPE PIT BOTTOM FOR DRAINAGE

NOTES:

1. All dimensions are in millimeters.
2. No tree pits shall be left open overnight.
3. Do not allow air pockets when backfilling.
4. Position crown of root ball 50mm above finish grade to allow for settling.
5. Water all plant material sufficiently to maintain vigorous, healthy growth from time of delivery/ installation until the end of the specified guarantee period.
6. For trees planted within planting or shrub beds, delete saucer around base of tree.
7. Remove all tree guards/ stakes 12 months after acceptance/ assumption or as specified.

VAUGHAN
DEVELOPMENT PLANNING DEPT.
URBAN DESIGN DIVISION

**CONIFEROUS TREE
PLANTING DETAIL FOR
TREES OVER 2500mm IN HEIGHT**

NOTE: THIS TYPICAL DETAIL IS INTENDED TO PROVIDE DESIGN DIRECTION AND IS FOR REFERENCE ONLY. IT MAY BE USED AS PART OF THE CONSTRUCTION PACKAGE OR SITE PLAN APPLICATION PROVIDED THE DETAIL IS CERTIFIED BY A REGISTERED LANDSCAPE ARCHITECT OR PROFESSIONAL ENGINEER AS APPLICABLE.

DRAWN & DESIGNED: URBAN DESIGN
NOT TO SCALE DATE: 03 / 01 / 2011

STD. DWG. NO.
ULA 104

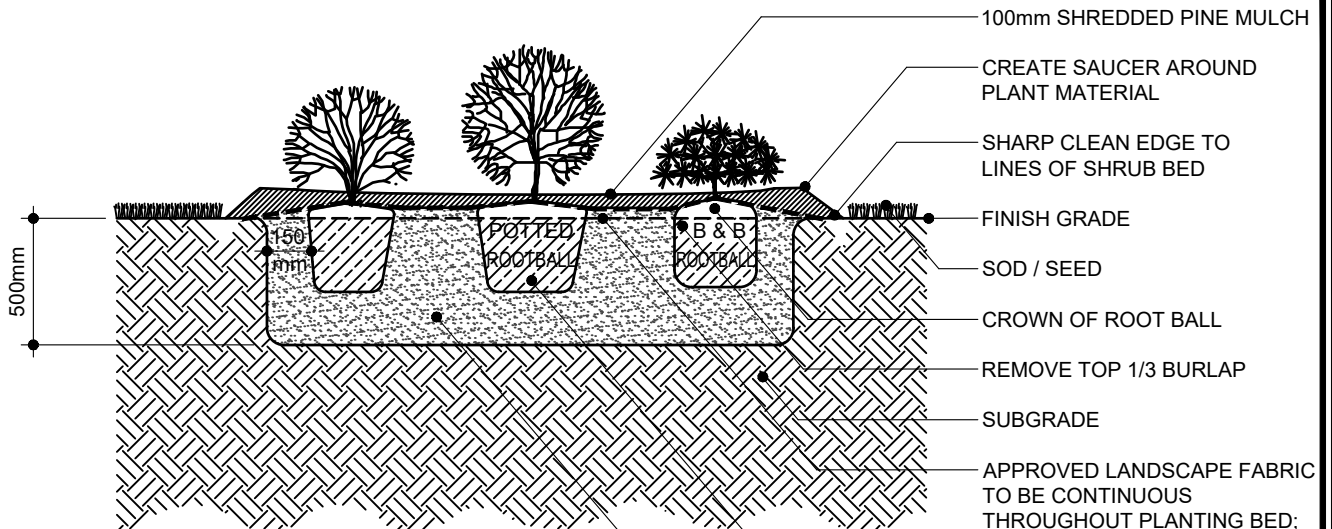

AT GRADE

NOTE:
ALL PLANT MATERIAL NOT MEETING CITY OF VAUGHAN REQUIREMENTS WILL BE REMOVED AND REPLACED AT NO EXPENSE TO THE CITY.

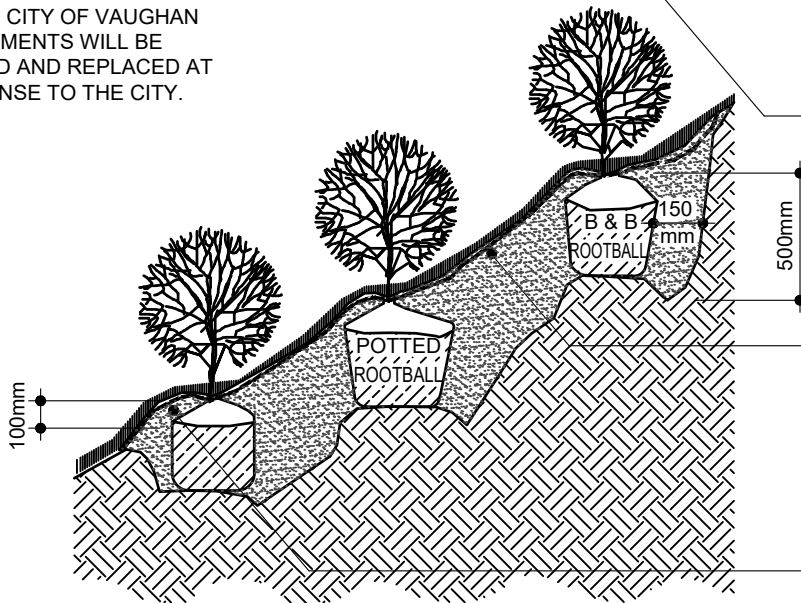

ON A SLOPE

- NOTES:**
1. All dimensions are in millimeters.
 2. Do not allow air pockets when backfilling.
 3. Position crown of root ball 50mm above finish grade to allow for settling.
 4. For bare root planting.
 5. Water all plant material sufficiently to maintain vigorous, healthy growth from time of delivery/ installation until the end of the specified guarantee period.

100mm SHREDDED PINE MULCH
 CREATE SAUCER AROUND PLANT MATERIAL
 SHARP CLEAN EDGE TO LINES OF SHRUB BED
 FINISH GRADE
 SOD / SEED
 CROWN OF ROOT BALL
 REMOVE TOP 1/3 BURLAP
 SUBGRADE
 APPROVED LANDSCAPE FABRIC TO BE CONTINUOUS THROUGHOUT PLANTING BED; HALF O.C.SPACING FROM ALL EDGES; INSTALL PLANT MATERIAL AS PER MANUFACTURER'S SPECIFICATIONS

FOR POTTED ROOT BALL REMOVE CONTAINER; SCARIFY EDGES AND MAINTAIN SOIL BALL
 500mm OF APPROVED SOIL MIXTURE THROUGHOUT SHRUB BED.
NOTE:
PLANTING AND SOIL AS ABOVE

APPROVED EROSION CONTROL MAT TO BE CONTINUOUS THROUGHOUT PLANTING BED; HALF O.C.SPACING FROM ALL EDGES; INSTALL WITH PLANT MATERIAL AS PER MANUFACTURER'S SPECIFICATIONS
 CREATE SAUCER AROUND PLANT MATERIAL AND ON DOWNWARD SIDE



VAUGHAN

**DEVELOPMENT PLANNING DEPT.
URBAN DESIGN DIVISION**

**SHRUB
PLANTING DETAIL**

NOTE: THIS TYPICAL DETAIL IS INTENDED TO PROVIDE DESIGN DIRECTION AND IS FOR REFERENCE ONLY. IT MAY BE USED AS PART OF THE CONSTRUCTION PACKAGE OR SITE PLAN APPLICATION PROVIDED THE DETAIL IS CERTIFIED BY A REGISTERED LANDSCAPE ARCHITECT OR PROFESSIONAL ENGINEER AS APPLICABLE.

DRAWN & DESIGNED: <u>URBAN DESIGN</u>	STD. DWG. NO. <u>ULA 105</u>
NOT TO SCALE	DATE: <u>03 / 01 / 2011</u>

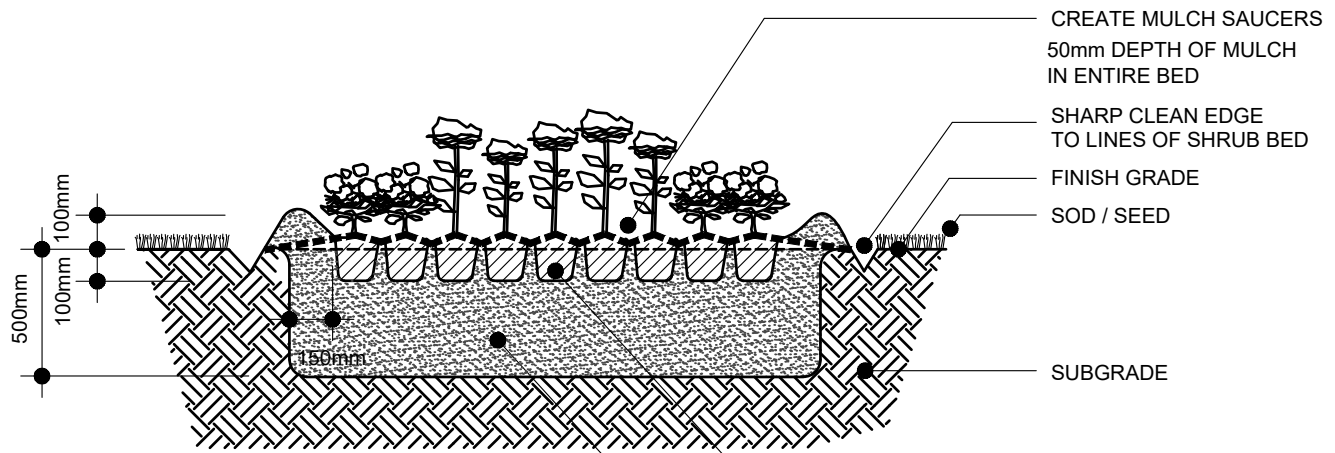

AT GRADE

CREATE MULCH SAUCERS
50mm DEPTH OF MULCH
IN ENTIRE BED
SHARP CLEAN EDGE
TO LINES OF SHRUB BED
FINISH GRADE
SOD / SEED

SUBGRADE

REMOVE CONTAINER OR CELL
PACK; MAINTAIN SOIL BALL

500mm OF SOIL MIXTURE
THROUGHOUT ANNUAL AND /
OR PERENNIAL BED

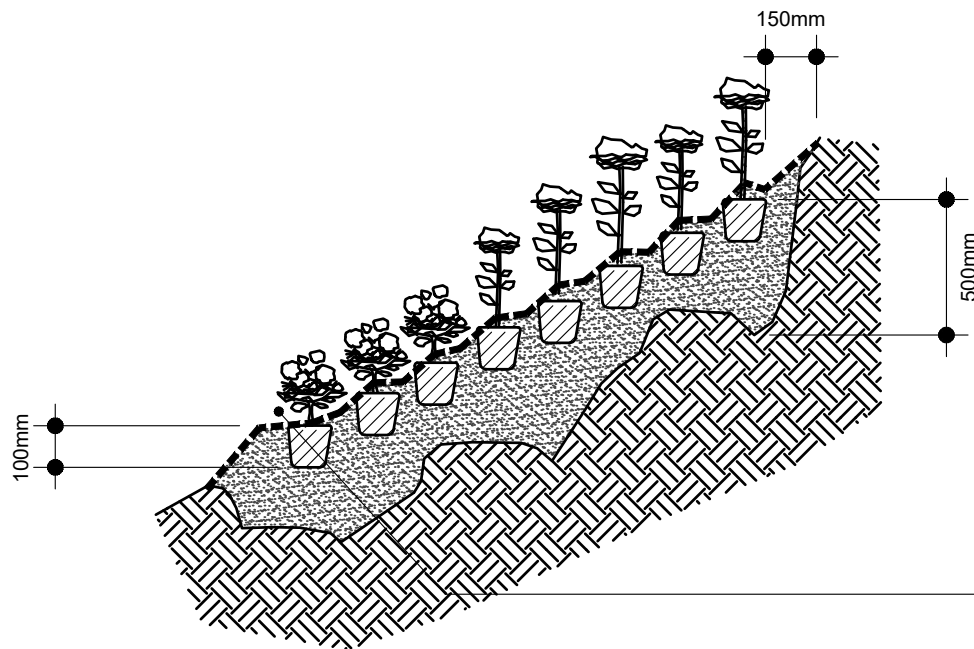

ON A SLOPE

CREATE SAUCER AROUND
PLANT MATERIAL AND ON
DOWNWARD SIDE

NOTES:

1. Do not allow air pockets when backfilling.
2. Position crown of annual / perennial at finish grade.
3. All dimensions are in millimeters.

VAUGHAN
DEVELOPMENT PLANNING DEPT.
URBAN DESIGN DIVISION

ANNUAL AND PERENNIAL
PLANTING DETAIL

NOTE: THIS TYPICAL DETAIL IS INTENDED TO PROVIDE DESIGN DIRECTION AND IS FOR REFERENCE ONLY. IT MAY BE USED AS PART OF THE CONSTRUCTION PACKAGE OR SITE PLAN APPLICATION PROVIDED THE DETAIL IS CERTIFIED BY A REGISTERED LANDSCAPE ARCHITECT OR PROFESSIONAL ENGINEER AS APPLICABLE.

DRAWN & DESIGNED: URBAN DESIGN

STD. DWG. NO.

NOT TO SCALE DATE: 03/01/2011

ULA 106

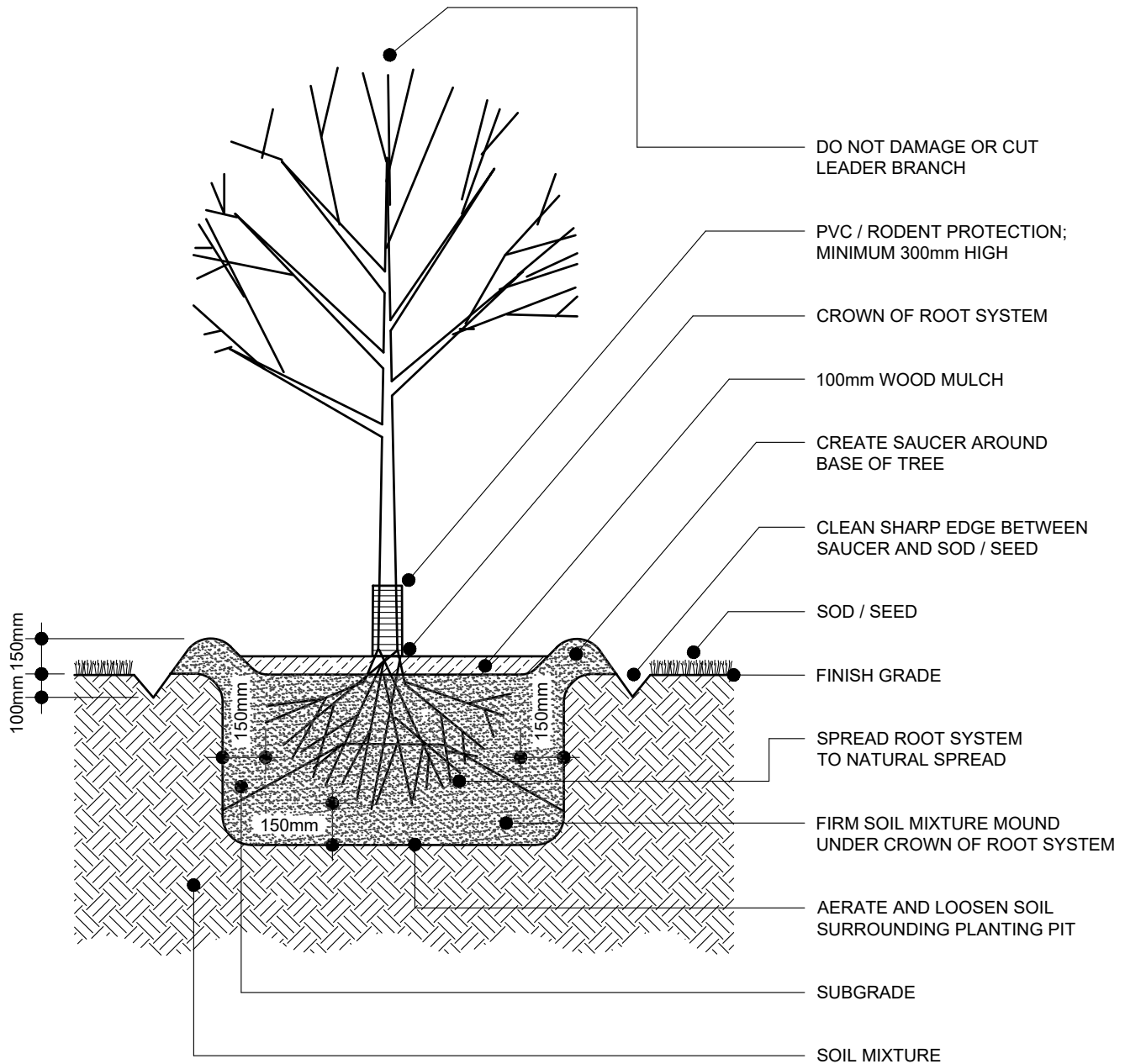

NOTES:

1. Do not allow air pockets when backfilling.
2. Do not damage root system when installing stakes.
3. Position crown of root system 100mm above finish grade.
4. Do corrective pruning to retain natural form of tree as directed by Landscape Architect.
5. For trees planted within planting or shrub beds, delete saucer around base of tree.
6. No tree pits shall be left open overnight.
7. If 1800mm or higher, add single tree stake.



VAUGHAN

DEVELOPMENT PLANNING DEPT.
URBAN DESIGN DIVISION

BARE ROOT TREE
PLANTING DETAIL FOR
TREES 30mm IN CALIPER OR LESS

NOTE: THIS TYPICAL DETAIL IS INTENDED TO PROVIDE DESIGN DIRECTION AND IS FOR REFERENCE ONLY. IT MAY BE USED AS PART OF THE CONSTRUCTION PACKAGE OR SITE PLAN APPLICATION PROVIDED THE DETAIL IS CERTIFIED BY A REGISTERED LANDSCAPE ARCHITECT OR PROFESSIONAL ENGINEER AS APPLICABLE.

DRAWN & DESIGNED: <u>URBAN DESIGN</u>	STD. DWG. NO. <u>ULA 107</u>
NOT TO SCALE	DATE: <u>03 / 01 / 2011</u>

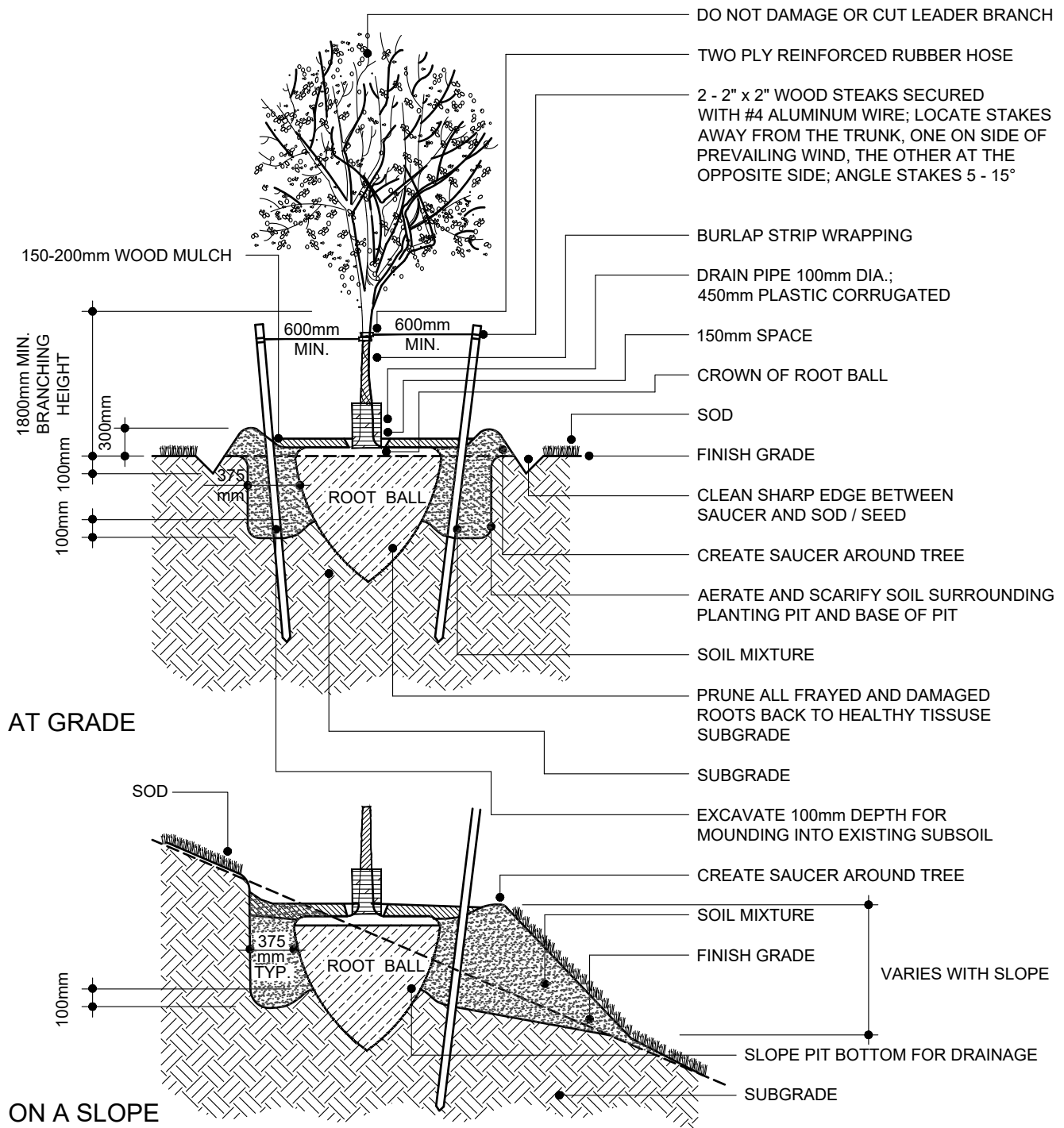

NOTES:

1. Do not allow air pockets when backfilling.
2. Position crown of root ball 50mm above finish grade to allow for settling.
3. Do corrective pruning to retain natural form of tree as directed by Landscape Architect.
4. For trees planted within planting or shrub beds delete saucer around base of tree.
5. All dimensions are in millimetres.
6. No tree pits shall be left open overnight.
7. Stake height shall be a minimum of 5' above finish grade.



VAUGHAN

DEVELOPMENT PLANNING DEPT.
URBAN DESIGN DIVISION

DECIDUOUS TREE
SPADE DETAIL FOR
TREES UNDER 90mm IN CALIPER

NOTE: THIS TYPICAL DETAIL IS INTENDED TO PROVIDE DESIGN DIRECTION AND IS FOR REFERENCE ONLY. IT MAY BE USED AS PART OF THE CONSTRUCTION PACKAGE OR SITE PLAN APPLICATION PROVIDED THE DETAIL IS CERTIFIED BY A REGISTERED LANDSCAPE ARCHITECT OR PROFESSIONAL ENGINEER AS APPLICABLE.

DRAWN & DESIGNED: <u>URBAN DESIGN</u>	STD. DWG. NO. <u>ULA 108</u>
NOT TO SCALE DATE: <u>03/01/2011</u>	

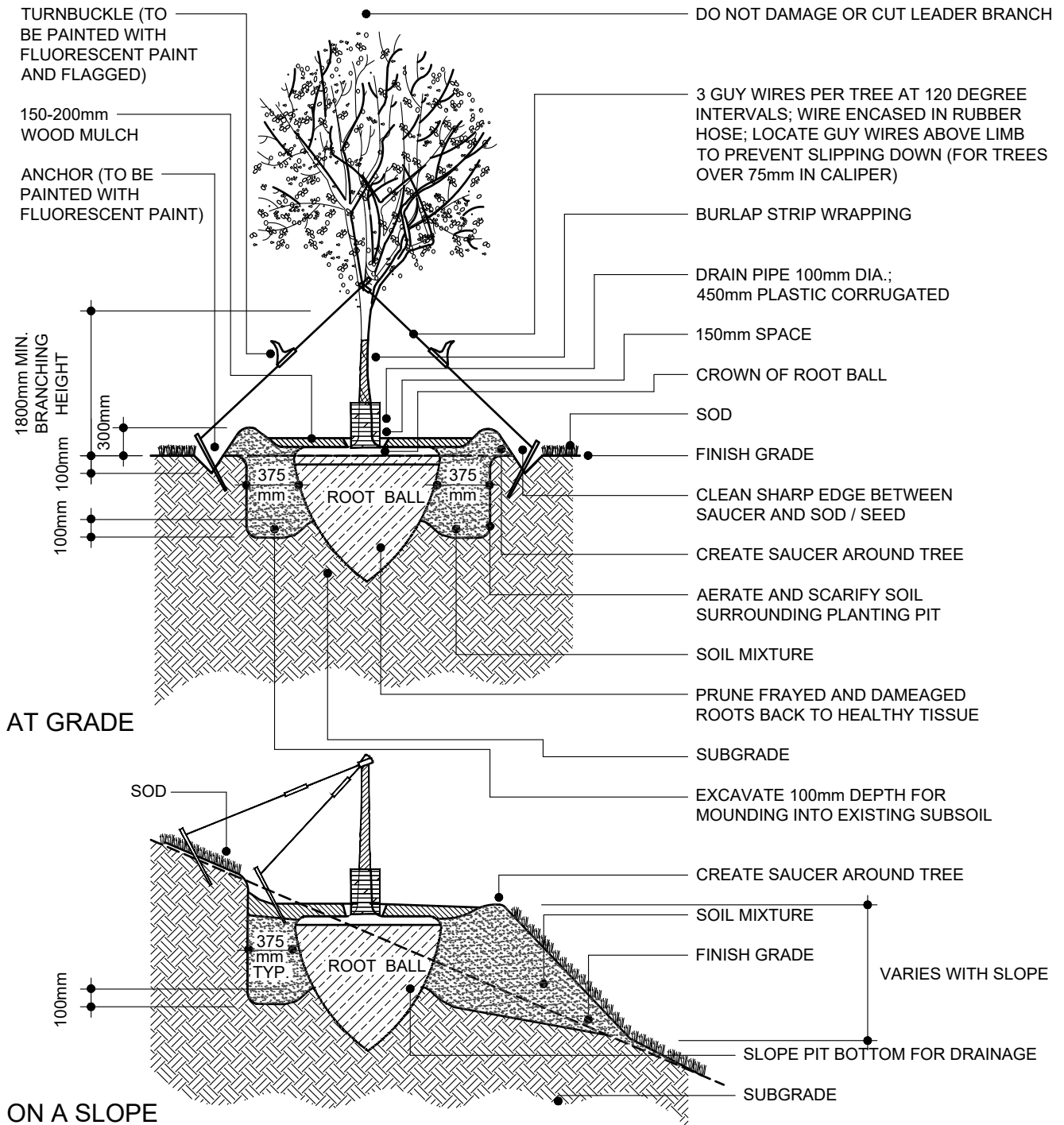

NOTES:

1. Do not allow air pockets when backfilling.
2. Position crown of root ball 50mm above finish grade to allow for settling.
3. Do corrective pruning to retain natural form of tree as directed by Landscape Architect.
4. For trees planted within planting or shrub beds delete saucer around base of tree.
5. All dimensions are in millimetres.
6. No tree pits shall be left open overnight.
7. For trees with root balls larger than 900mm, refer to specifications for tree pit size.



VAUGHAN
 DEVELOPMENT PLANNING DEPT.
 URBAN DESIGN DIVISION

**DECIDUOUS TREE
 SPADE DETAIL FOR
 TREES OVER 90mm IN CALIPER**

NOTE: THIS TYPICAL DETAIL IS INTENDED TO PROVIDE DESIGN DIRECTION AND IS FOR REFERENCE ONLY. IT MAY BE USED AS PART OF THE CONSTRUCTION PACKAGE OR SITE PLAN APPLICATION PROVIDED THE DETAIL IS CERTIFIED BY A REGISTERED LANDSCAPE ARCHITECT OR PROFESSIONAL ENGINEER AS APPLICABLE.

DRAWN & DESIGNED: URBAN DESIGN
 NOT TO SCALE DATE: 03 / 01 / 2011

STD. DWG. NO.
ULA 109

Note: When 1800mm drip line distance is not attainable, hoarding should be at least 3000mm from outside edge of tree trunk.

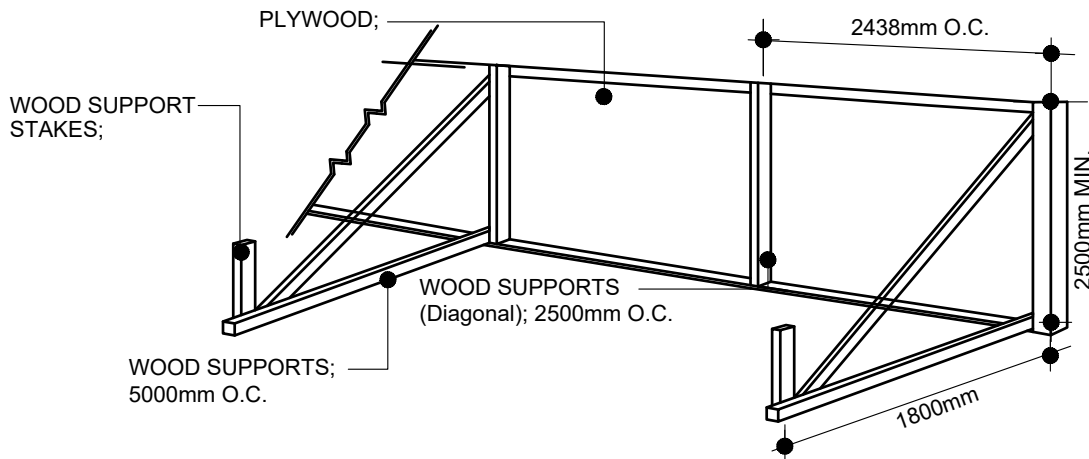
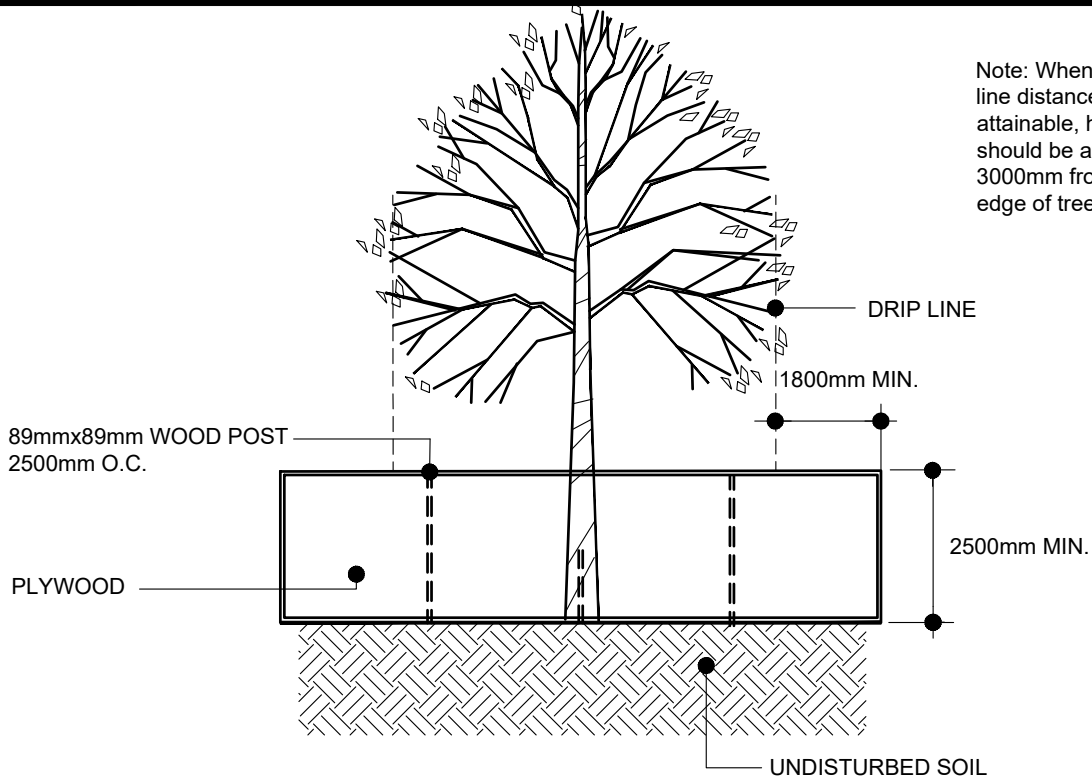

Note: All Support Stakes and Hoarding Posts to be wood 2" x 4" member.

Note: All Plywood to be 4'x8' sheets.

Note: All Connection Points to be Rigid.

NOTES:

1. Attachment of fence to trees to be preserved is not allowed.
2. Ensure fence is continuous and is located beyond the drip line of trees to be preserved.
3. Fencing to be installed prior to start of construction.
4. All supports and bracing should be inside the Tree Protection Zone. All such supports should minimize damaging roots outside the Tree Protection Barrier.
5. No Construction activity, grade changes, surface treatment or excavations of any kind is permitted within the Tree Protection Zone.



HEAVY DUTY TREE HOARDING PROTECTION DETAIL (PLYWOOD)

NOTE: THIS TYPICAL DETAIL IS INTENDED TO PROVIDE DESIGN DIRECTION AND IS FOR REFERENCE ONLY. IT MAY BE USED AS PART OF THE CONSTRUCTION PACKAGE OR SITE PLAN APPLICATION PROVIDED THE DETAIL IS CERTIFIED BY A REGISTERED LANDSCAPE ARCHITECT OR PROFESSIONAL ENGINEER AS APPLICABLE.

DRAWN & DESIGNED: URBAN DESIGN

STD. DWG. NO.

NOT TO SCALE DATE: 04 / 07 / 2016

ULA 110A

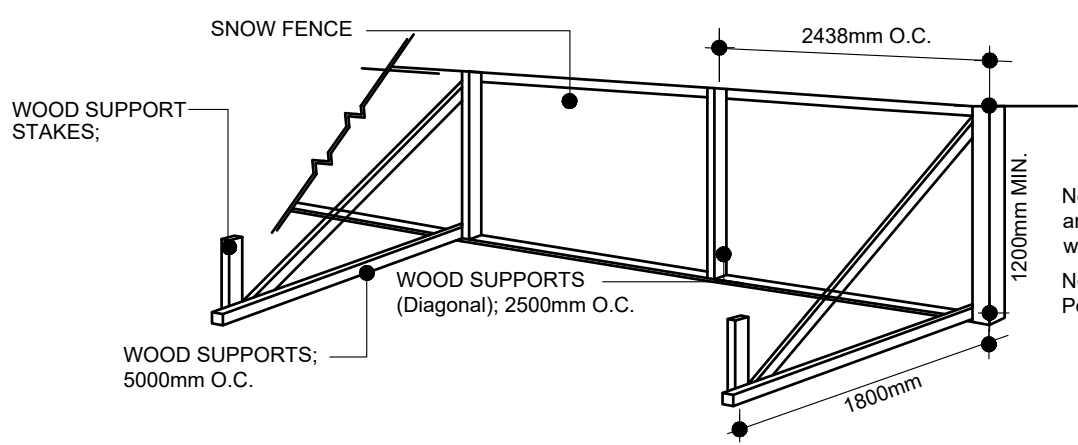
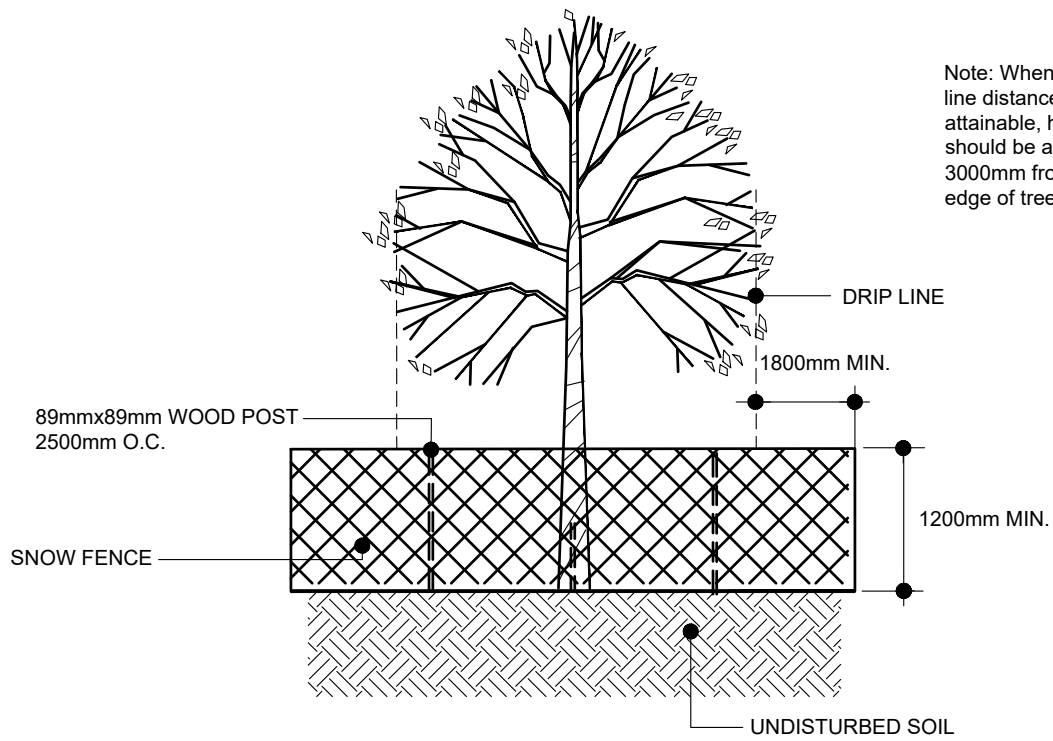

Note: All Support Stakes and Hoarding Posts to be wood 2" x 4" member.
Note: All Connection Points to be Rigid.

NOTES:

1. Attachment of fence to trees to be preserved is not allowed.
2. Ensure fence is continuous and is located beyond the drip line of trees to be preserved.
3. Fencing to be installed prior to start of construction.
4. All supports and bracing should be inside the Tree Protection Zone. All such supports should minimize damaging roots outside the Tree Protection Barrier.
5. No Construction activity, grade changes, surface treatment or excavations of any kind is permitted within the Tree Protection Zone.

VAUGHAN
DEVELOPMENT PLANNING DEPT.
URBAN DESIGN DIVISION

**LIGHT DUTY TREE HOARDING
PROTECTION DETAIL (SNOW FENCE)**

NOTE: THIS TYPICAL DETAIL IS INTENDED TO PROVIDE DESIGN DIRECTION AND IS FOR REFERENCE ONLY. IT MAY BE USED AS PART OF THE CONSTRUCTION PACKAGE OR SITE PLAN APPLICATION PROVIDED THE DETAIL IS CERTIFIED BY A REGISTERED LANDSCAPE ARCHITECT OR PROFESSIONAL ENGINEER AS APPLICABLE.

DRAWN & DESIGNED: URBAN DESIGN
NOT TO SCALE DATE: 04 / 07 / 2016

STD. DWG. NO.
ULA 110B

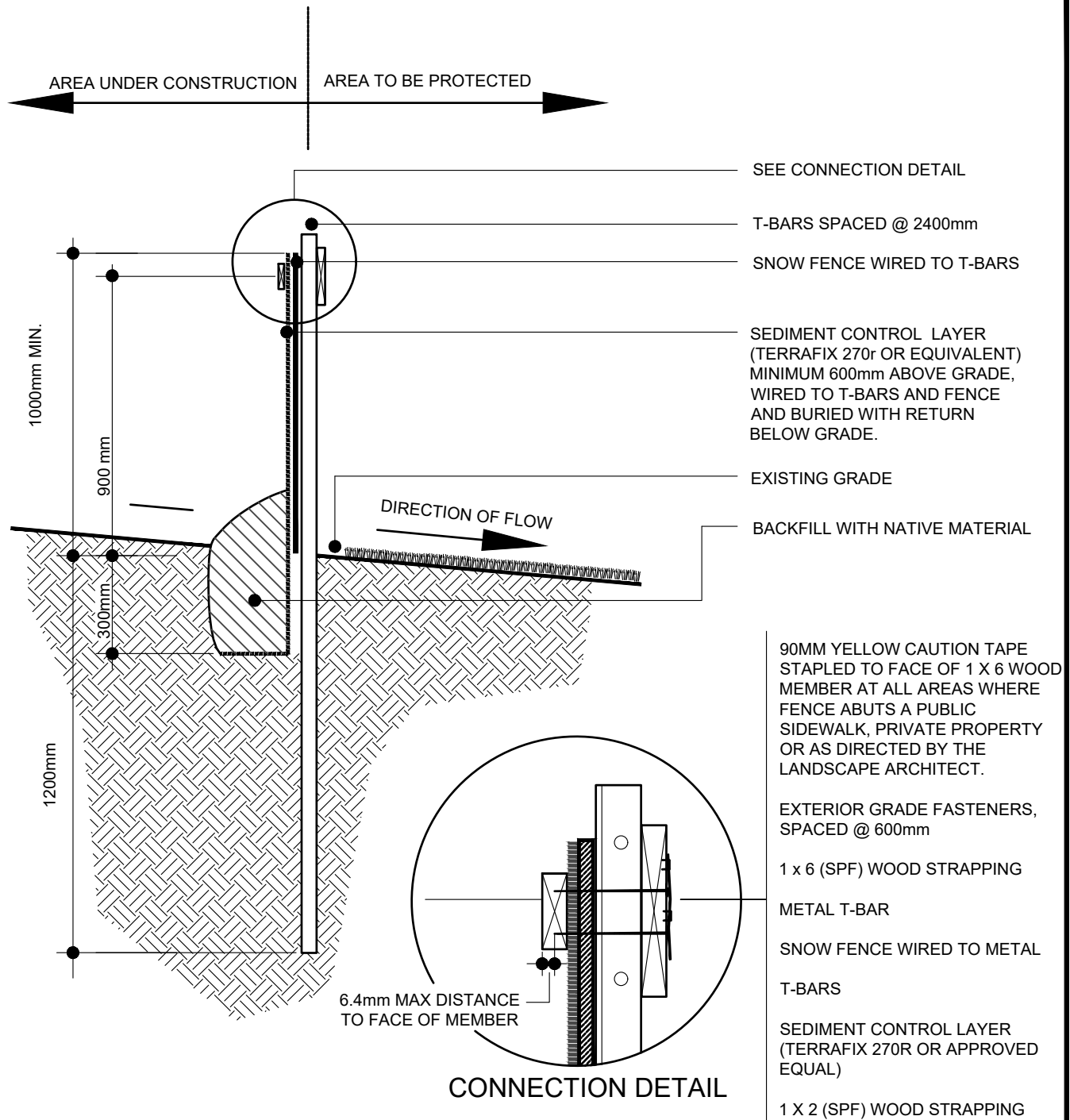

NOTES:

1. SEDIMENT CONTROL FABRIC TO HAVE HORIZONTAL OVERLAP OF 1000mm @ ALL JOINTS
2. THE GENERAL CONTRACTOR IS RESPONSIBLE FOR THE RESTORATION AND COST OF REPLACING ALL AREAS AND MATERIAL AFFECTED BY THE EXCAVATION FOR THE SEDIMENT CONTROL FENCE.
3. ALL FASTENERS ARE TO BE FLUSH WITH FACE OF MEMBERS. THE GENERAL CONTRACTOR IS RESPONSIBLE TO GRIND OR REMOVE ALL FASTENERS THAT PROJECT THROUGH FACE OF MEMBERS
4. ALL DIMENSIONS SHOWN IN MILLIMETERS



VAUGHAN
DEVELOPMENT PLANNING DEPT.
URBAN DESIGN DIVISION

**SEDIMENT CONTROL
CONSTRUCTION FENCING DETAIL**

NOTE: THIS TYPICAL DETAIL IS INTENDED TO PROVIDE DESIGN DIRECTION AND IS FOR REFERENCE ONLY. IT MAY BE USED AS PART OF THE CONSTRUCTION PACKAGE OR SITE PLAN APPLICATION PROVIDED THE DETAIL IS CERTIFIED BY A REGISTERED LANDSCAPE ARCHITECT OR PROFESSIONAL ENGINEER AS APPLICABLE.

DRAWN & DESIGNED: URBAN DESIGN

STD. DWG. NO.

NOT TO SCALE DATE: 03 / 01 / 2011

ULA 111

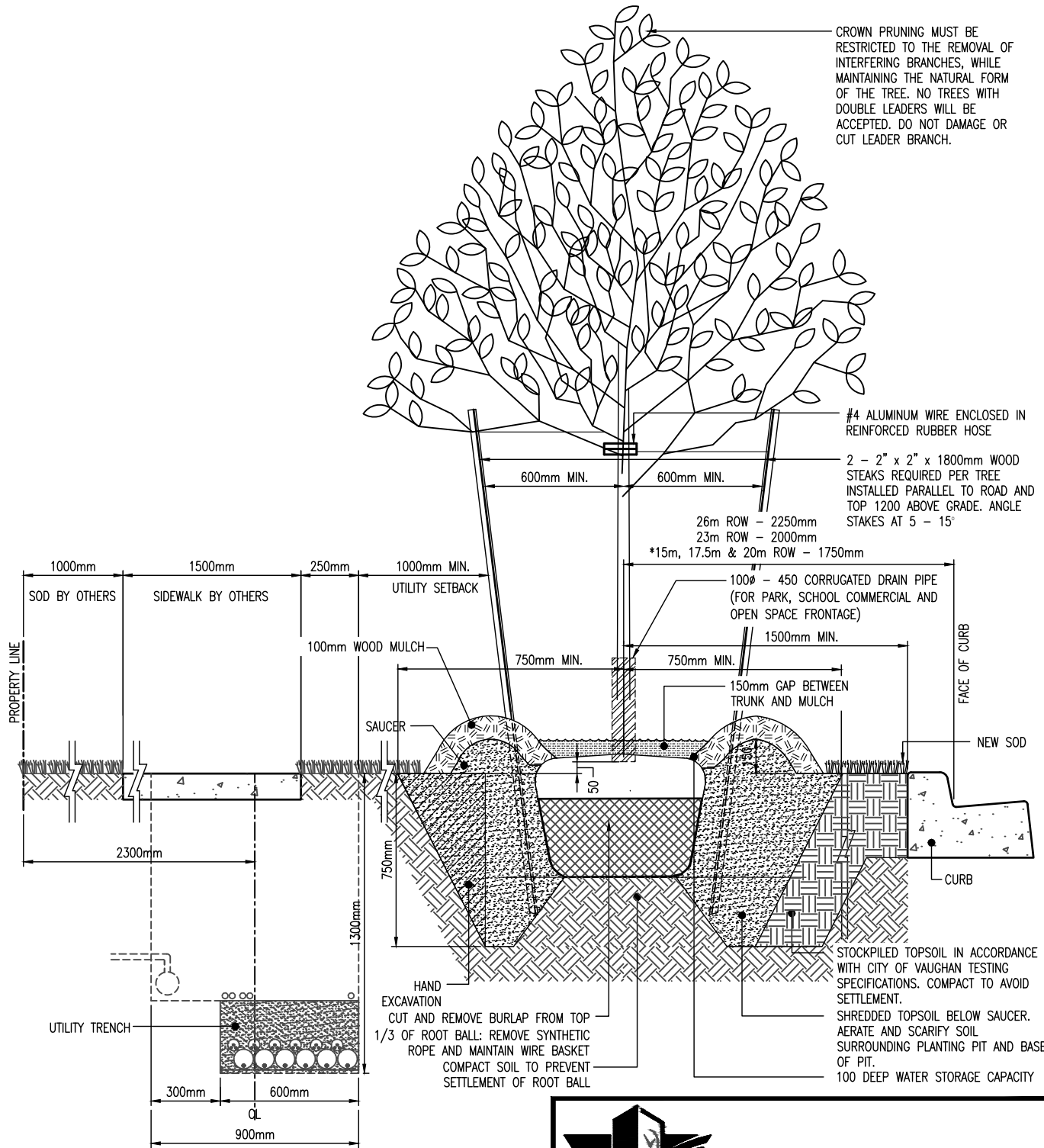

CROWN PRUNING MUST BE RESTRICTED TO THE REMOVAL OF INTERFERING BRANCHES, WHILE MAINTAINING THE NATURAL FORM OF THE TREE. NO TREES WITH DOUBLE LEADERS WILL BE ACCEPTED. DO NOT DAMAGE OR CUT LEADER BRANCH.

#4 ALUMINUM WIRE ENCLOSED IN REINFORCED RUBBER HOSE
 2 - 2" x 2" x 1800mm WOOD STEAKS REQUIRED PER TREE INSTALLED PARALLEL TO ROAD AND TOP 1200 ABOVE GRADE. ANGLE STAKES AT 5 - 15°

26m ROW - 2250mm
 23m ROW - 2000mm
 *15m, 17.5m & 20m ROW - 1750mm

1000mm SOD BY OTHERS
 1500mm SIDEWALK BY OTHERS
 250mm
 1000mm MIN. UTILITY SETBACK

PROPERTY LINE

FACE OF CURB

NEW SOD

CURB

STOCKPILED TOPSOIL IN ACCORDANCE WITH CITY OF VAUGHAN TESTING SPECIFICATIONS. COMPACT TO AVOID SETTLEMENT.
 SHREDDED TOPSOIL BELOW SAUCER. AERATE AND SCARIFY SOIL SURROUNDING PLANTING PIT AND BASE OF PIT.
 100 DEEP WATER STORAGE CAPACITY

HAND EXCAVATION
 CUT AND REMOVE BURLAP FROM TOP 1/3 OF ROOT BALL; REMOVE SYNTHETIC ROPE AND MAINTAIN WIRE BASKET
 COMPACT SOIL TO PREVENT SETTLEMENT OF ROOT BALL

SOURCE: CITY OF VAUGHAN
 STANDARD DRAWINGS B-8, B-10 TO B-13
 *DETAIL NOT APPLICABLE ON BUFFER SIDE OF STREET FOR 15M ROW.

NOTE:
 1. TREES SHALL HAVE ACCESS TO A MINIMUM OF 20 CUBIC METERS OF GROWING MEDIUM.

VAUGHAN
 DEVELOPMENT PLANNING DEPT.
 URBAN DESIGN DIVISION

BOULEVARD TREE DETAIL SECTION

NOTE: THIS TYPICAL DETAIL IS INTENDED TO PROVIDE DESIGN DIRECTION AND IS FOR REFERENCE ONLY. IT MAY BE USED AS PART OF THE CONSTRUCTION PACKAGE OR SITE PLAN APPLICATION PROVIDED THE DETAIL IS CERTIFIED BY A REGISTERED LANDSCAPE ARCHITECT OR PROFESSIONAL ENGINEER AS APPLICABLE.

DRAWN & DESIGNED: PCA
 NOT TO SCALE DATE: 03/01/2011

STD. DWG. NO. ULA 202

BOULEVARD PLANTING GENERAL NOTES

1. PRIOR TO THE INSTALLATION, A STAKEOUT OF BOULEVARD TREE LOCATIONS IS TO BE UNDERTAKEN BY THE OWNER, TO THE APPROVAL OF THE CITY. THE OWNER SHALL ENSURE ALL UNDERGROUND UTILITIES (EXISTING AND PROPOSED) ARE STAKED OUT PRIOR TO THE BOULEVARD TREE STAKEOUT. THE LANDSCAPE CONSULTANT AND THE CITY MAY, AT THEIR DISCRETION, REDISTRIBUTE TREE LOCATIONS, PRIOR TO PLANTING, IN ORDER TO MINIMIZE CONFLICTS WITH UTILITIES, DRIVEWAYS, AND INTERSECTION VISIBILITY. THE FOLLOWING DISTANCES ARE TO BE ENSURED IN THE LOCATION OF TREES WITHIN THE BOULEVARD:

- NOT LESS THAN 1.0 METRE FROM PEDESTRIAN SIDEWALKS, STREET CURBS, RESIDENTIAL / COMMERCIAL / INDUSTRIAL DRIVEWAYS, UNDERGROUND UTILITIES, UTILITY PEDESTALS, AND SANITARY / STORM / WATER CONNECTIONS. A 3.0 METRES SETBACK IS PREFERRED FROM ALL PAVING SURFACES WHENEVER POSSIBLE.
- NOT LESS THAN 3.0 METRES FROM HYDRO TRANSFORMERS, FIRE HYDRANTS, COMMUNITY MAILBOX PADS, AND WATER VALVES & CHAMBERS.
- NOT LESS THAN 5.0 METRES FROM LIGHT POLES (3.0 METRES FOR COLUMNAR TREE VARIETIES AND SMALLER ORNAMENTAL / FLOWERING TREE SPECIES).
- NOT LESS THAN 15.0 METRES FROM STOP SIGNS, SUBJECT TO THE APPROVAL OF THE CITY'S ENGINEERING DEPT.
- TREES ADJACENT TO INTERSECTIONS SHALL MAINTAIN AN APPROPRIATE SETBACK TO ENSURE THAT NO FUTURE CROWN GROWTH ENCROACHES WITHIN THE DAYLIGHT TRIANGLE.

2. PROVIDE SAMPLE OF SHREDDED BARK CHIP MULCH PRIOR TO CONSTRUCTION.

3. PROVIDE TOPSOIL TESTING RESULTS PRIOR TO CONSTRUCTION.

4. ORIENT TREES FOR BEST APPEARANCE.

5. NO TREE PITS SHALL BE LEFT OPEN OVERNIGHT.

6. ANY TREE REPLACED DURING THE MAINTENANCE PERIOD REQUIRE'S 2"X 2" WOODEN STAKES (6'-0") AS OPPOSED TO '1' BARS.

7. ALL TREES NOT MEETING CITY OF VAUGHAN REQUIREMENTS WILL BE REMOVED AND REPLACED AT NO EXPENSE TO THE CITY.

8. ALL STAKES AND ACCESSORIES SHALL BE REMOVED PRIOR TO THE INSPECTION FOR SUBDIVISION MAINTENANCE.

9. STRAIGHTEN ALL LEANING TREES PRIOR TO INSPECTION FOR SUBDIVISION MAINTENANCE.

10. CORRECTIVE PRUNING SHALL BE COMPLETED PRIOR TO INSPECTION FOR SUBDIVISION MAINTENANCE IN ACCORDANCE OF INDUSTRY STANDARDS, INCLUDING THE REMOVAL OF:

PRUNING TO INCLUDE THE REMOVAL OF:

- ONE WHORL OF BRANCHES FROM THE LOWER CROWN
- DEAD OR BROKEN BRANCHES
- TRUNK SUCKERS
- CO-DOMINANT LEADERS

11. TOP DRESS ANY SETTLEMENT AREA WITH TOPSOIL AND SOD PRIOR TO SUBDIVISION ASSUMPTION.

	<h2 style="margin: 0;">VAUGHAN</h2> <p style="margin: 0;">DEVELOPMENT PLANNING DEPT. URBAN DESIGN DIVISION</p>
<p>BOULEVARD TREE DETAIL GENERAL NOTES</p>	
<p>NOTE: THIS TYPICAL DETAIL IS INTENDED TO PROVIDE DESIGN DIRECTION AND IS FOR REFERENCE ONLY. IT MAY BE USED AS PART OF THE CONSTRUCTION PACKAGE OR SITE PLAN APPLICATION PROVIDED THE DETAIL IS CERTIFIED BY A REGISTERED LANDSCAPE ARCHITECT OR PROFESSIONAL ENGINEER AS APPLICABLE.</p>	
<p>DRAWN & DESIGNED: <u>PCA</u></p> <p>NOT TO SCALE DATE: <u>03 / 01 / 2011</u></p>	<p>STD. DWG. NO. <u>ULA 203</u></p>

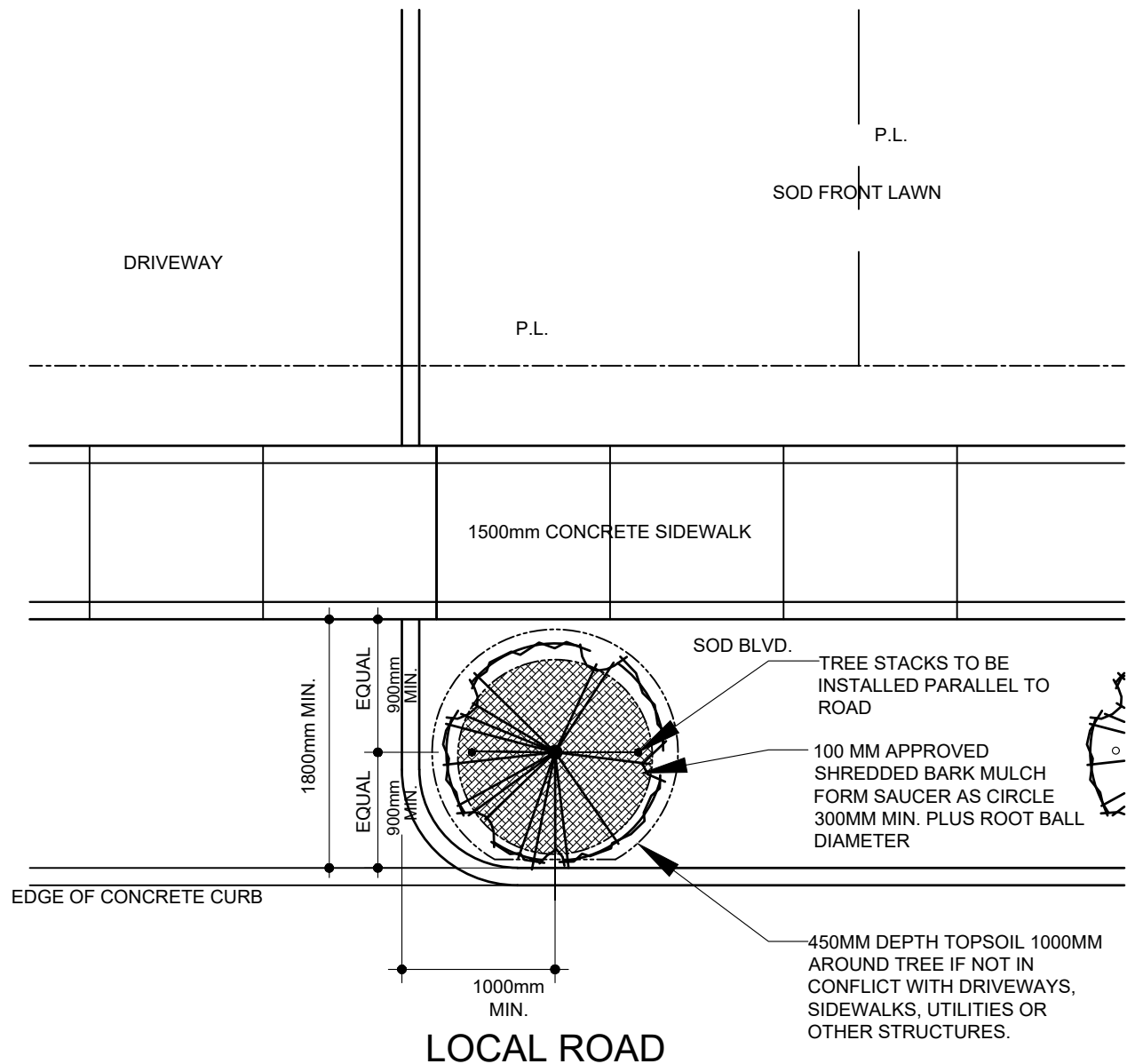

Stakeout of Boulevard Tree Locations

All operations regarding boulevard tree stake out and implementation are to be inspected and certified by the consulting Landscape Architect and City Forestry Representative. The Owner shall ensure all underground utilities (existing and proposed) are staked out prior to the boulevard tree stake out. Please note that Vaughan Hydro has identified specific requirements associated with the location of trees relative to their underground systems.

The following distances are to be ensured in the location of trees within the boulevard:

- * not less than 1.0 metre from underground utilities, sidewalks and driveways.
- * not less than 0.900 of a metre from underground gas utilities
- * not less than 3 metres from light poles, with trees to be located only on one side of the light pole (using Pyramidal or Columnar Tree Species)
- * cannot be planted in utility easements

VAUGHAN
DEVELOPMENT PLANNING DEPT.
URBAN DESIGN DIVISION

BOULEVARD TREE DETAIL DRIVEWAY LAYOUT

NOTE: THIS TYPICAL DETAIL IS INTENDED TO PROVIDE DESIGN DIRECTION AND IS FOR REFERENCE ONLY. IT MAY BE USED AS PART OF THE CONSTRUCTION PACKAGE OR SITE PLAN APPLICATION PROVIDED THE DETAIL IS CERTIFIED BY A REGISTERED LANDSCAPE ARCHITECT OR PROFESSIONAL ENGINEER AS APPLICABLE.

DRAWN & DESIGNED: URBAN DESIGN

STD. DWG. NO.

NOT TO SCALE DATE: 03/01/2011

ULA 204

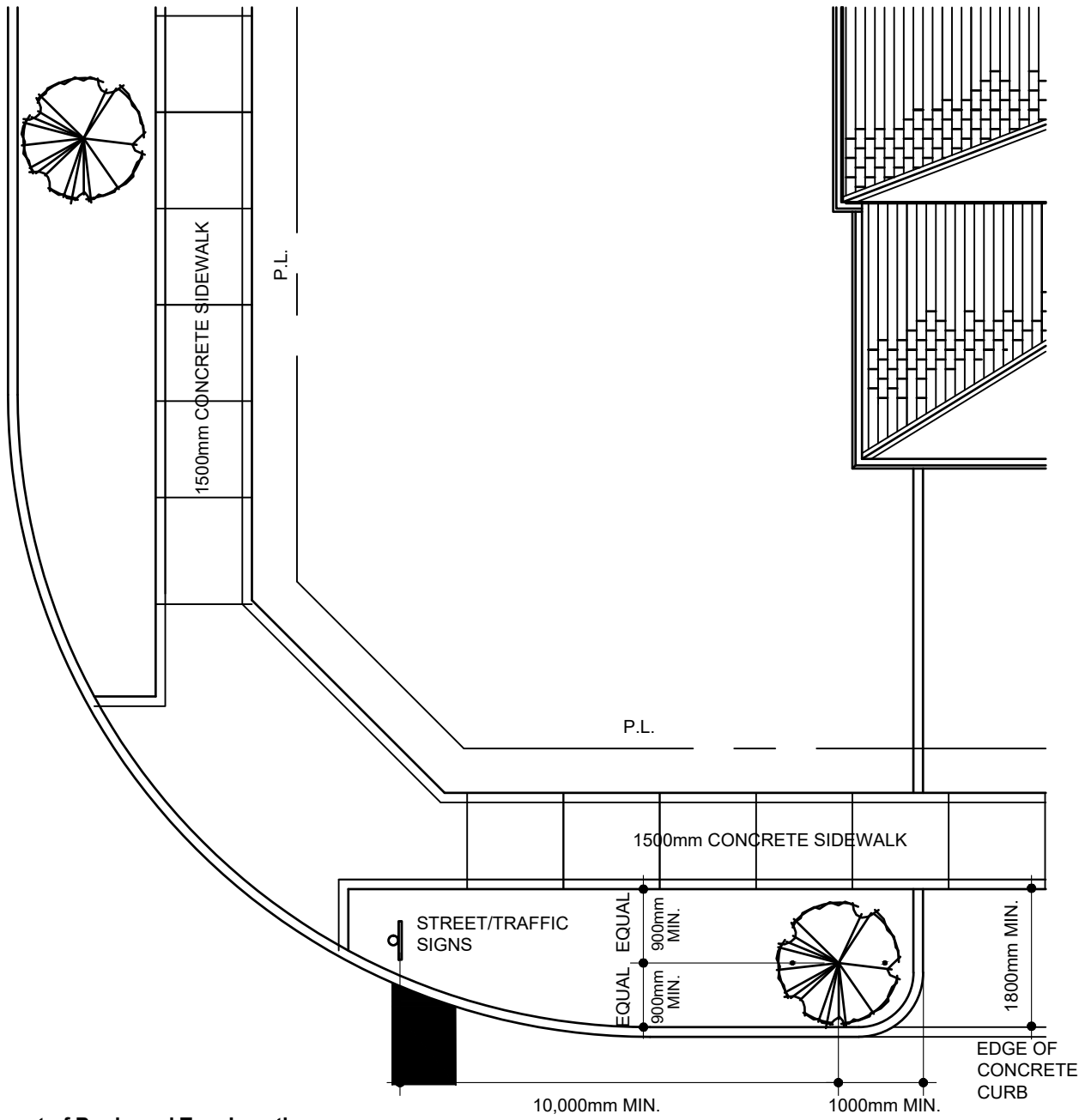

Stakeout of Boulevard Tree Locations

All operations regarding boulevard tree stake out and implementation are to be inspected and certified by the consulting Landscape Architect and City Forestry Representative. The Owner shall ensure all underground utilities (existing and proposed) are staked out prior to the boulevard tree stake out. Please note that Vaughan Hydro has identified specific requirements associated with the location of trees relative to their underground systems.

The following distances are to be ensured in the location of trees within the boulevard:

- * not less than 1.0 metre from underground utilities, sidewalks and driveways.
- * not less than 0.900 of a metre from underground gas utilities
- * not less than 15 metres from stop signs, subject to the approval of the Engineering Department
- * cannot be planted in utility easements

LOCAL ROAD

VAUGHAN
DEVELOPMENT PLANNING DEPT.
URBAN DESIGN DIVISION

**BOULEVARD TREE DETAIL
STREET/TRAFFIC SIGN LAYOUT**

NOTE: THIS TYPICAL DETAIL IS INTENDED TO PROVIDE DESIGN DIRECTION AND IS FOR REFERENCE ONLY. IT MAY BE USED AS PART OF THE CONSTRUCTION PACKAGE OR SITE PLAN APPLICATION PROVIDED THE DETAIL IS CERTIFIED BY A REGISTERED LANDSCAPE ARCHITECT OR PROFESSIONAL ENGINEER AS APPLICABLE.

DRAWN & DESIGNED: URBAN DESIGN
NOT TO SCALE DATE: 03 / 01 / 2011

STD. DWG. NO.
ULA 205

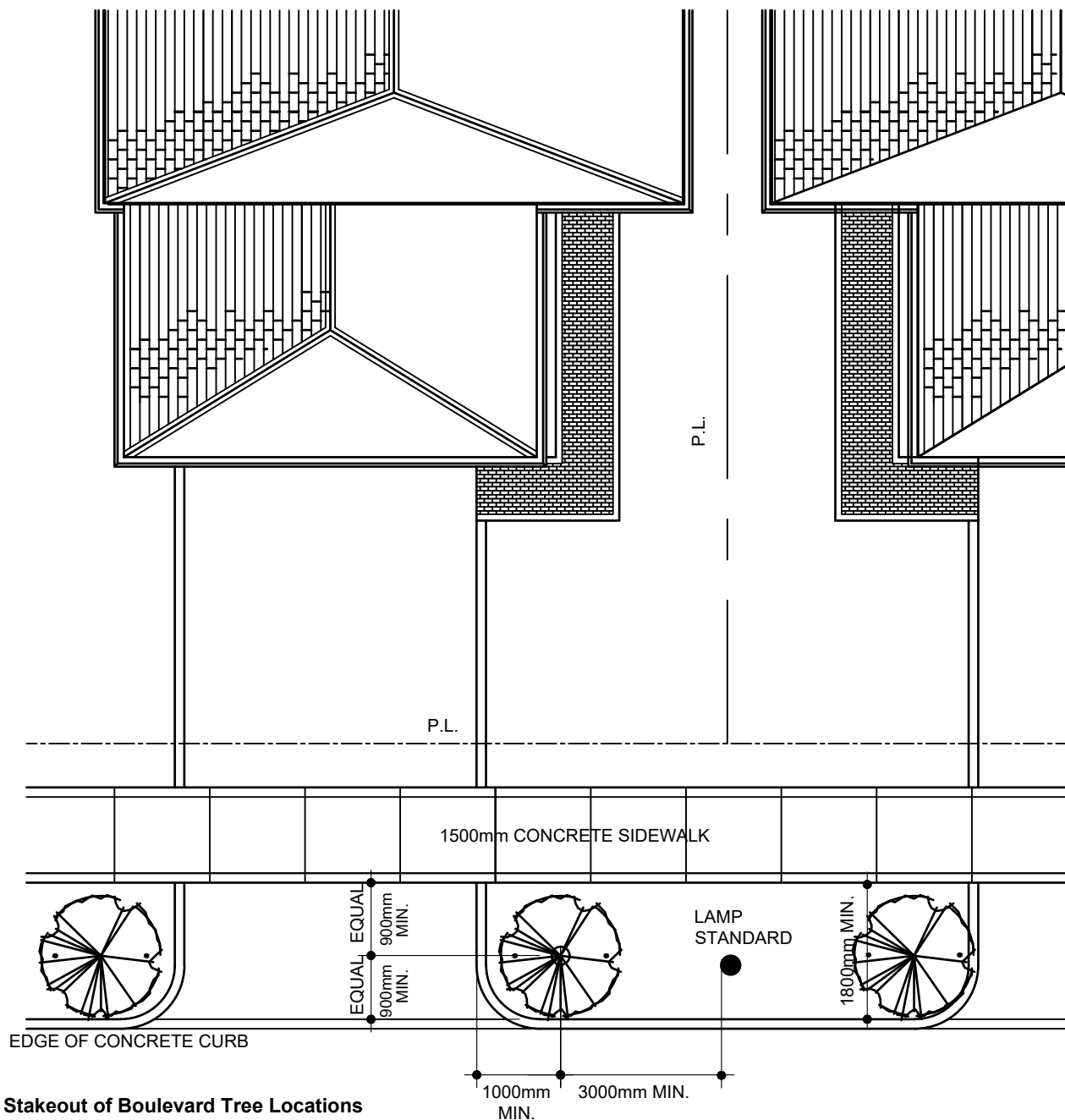

Stakeout of Boulevard Tree Locations

All operations regarding boulevard tree stake out and implementation are to be inspected and certified by the consulting Landscape Architect and City Forestry Representative. The Owner shall ensure all underground utilities (existing and proposed) are staked out prior to the boulevard tree stake out. Please note that Vaughan Hydro has identified specific requirements associated with the location of trees relative to their underground systems.

The following distances are to be ensured in the location of trees within the boulevard:

- * not less than 1.0 metre from underground utilities, sidewalks and driveways.
- * not less than 0.900 of a metre from underground gas utilities
- * not less than 3 metres from light poles, with trees to be located only on one side of the light pole (use Pyramidal or Columnar Tree Species)
- * cannot be planted in utility easements

LOCAL ROAD

VAUGHAN
DEVELOPMENT PLANNING DEPT.
URBAN DESIGN DIVISION

**BOULEVARD TREE DETAIL
STREET LIGHT POLE LAYOUT**

NOTE: THIS TYPICAL DETAIL IS INTENDED TO PROVIDE DESIGN DIRECTION AND IS FOR REFERENCE ONLY. IT MAY BE USED AS PART OF THE CONSTRUCTION PACKAGE OR SITE PLAN APPLICATION PROVIDED THE DETAIL IS CERTIFIED BY A REGISTERED LANDSCAPE ARCHITECT OR PROFESSIONAL ENGINEER AS APPLICABLE.

DRAWN & DESIGNED: URBAN DESIGN

STD. DWG. NO.

NOT TO SCALE DATE: 03/01/2011

ULA 206

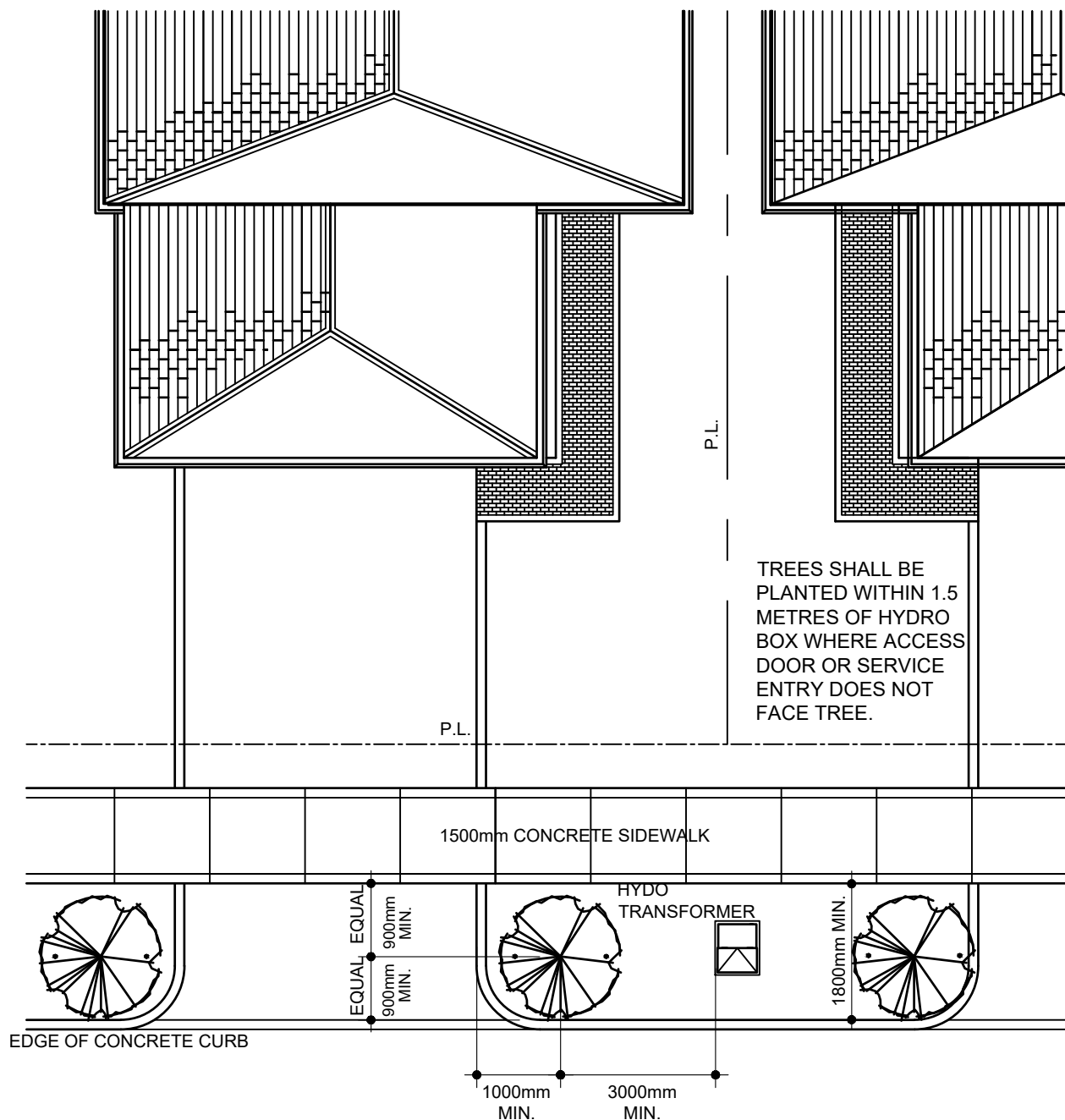

Stakeout of Boulevard Tree Locations

All operations regarding boulevard tree stake out and implementation are to be inspected and certified by the consulting Landscape Architect and City Forestry Representative. The Owner shall ensure all underground utilities (existing and proposed) are staked out prior to the boulevard tree stake out. Please note that Vaughan Hydro has identified specific requirements associated with the location of trees relative to their underground systems.

The following distances are to be ensured in the location of trees within the boulevard:

- * not less than 1.0 metre from underground utilities, sidewalks and driveways
- * not less than 3.0 metres from hydro transformers
- * not less than 0.900 of a metre from underground gas utilities
- * cannot be planted in utility easements

LOCAL ROAD



**BOULEVARD TREE DETAIL
HYDRO TRANSFORMER LAYOUT**

NOTE: THIS TYPICAL DETAIL IS INTENDED TO PROVIDE DESIGN DIRECTION AND IS FOR REFERENCE ONLY. IT MAY BE USED AS PART OF THE CONSTRUCTION PACKAGE OR SITE PLAN APPLICATION PROVIDED THE DETAIL IS CERTIFIED BY A REGISTERED LANDSCAPE ARCHITECT OR PROFESSIONAL ENGINEER AS APPLICABLE.

DRAWN & DESIGNED: URBAN DESIGN

STD. DWG. NO.

NOT TO SCALE DATE: 03/01/2011

ULA 207

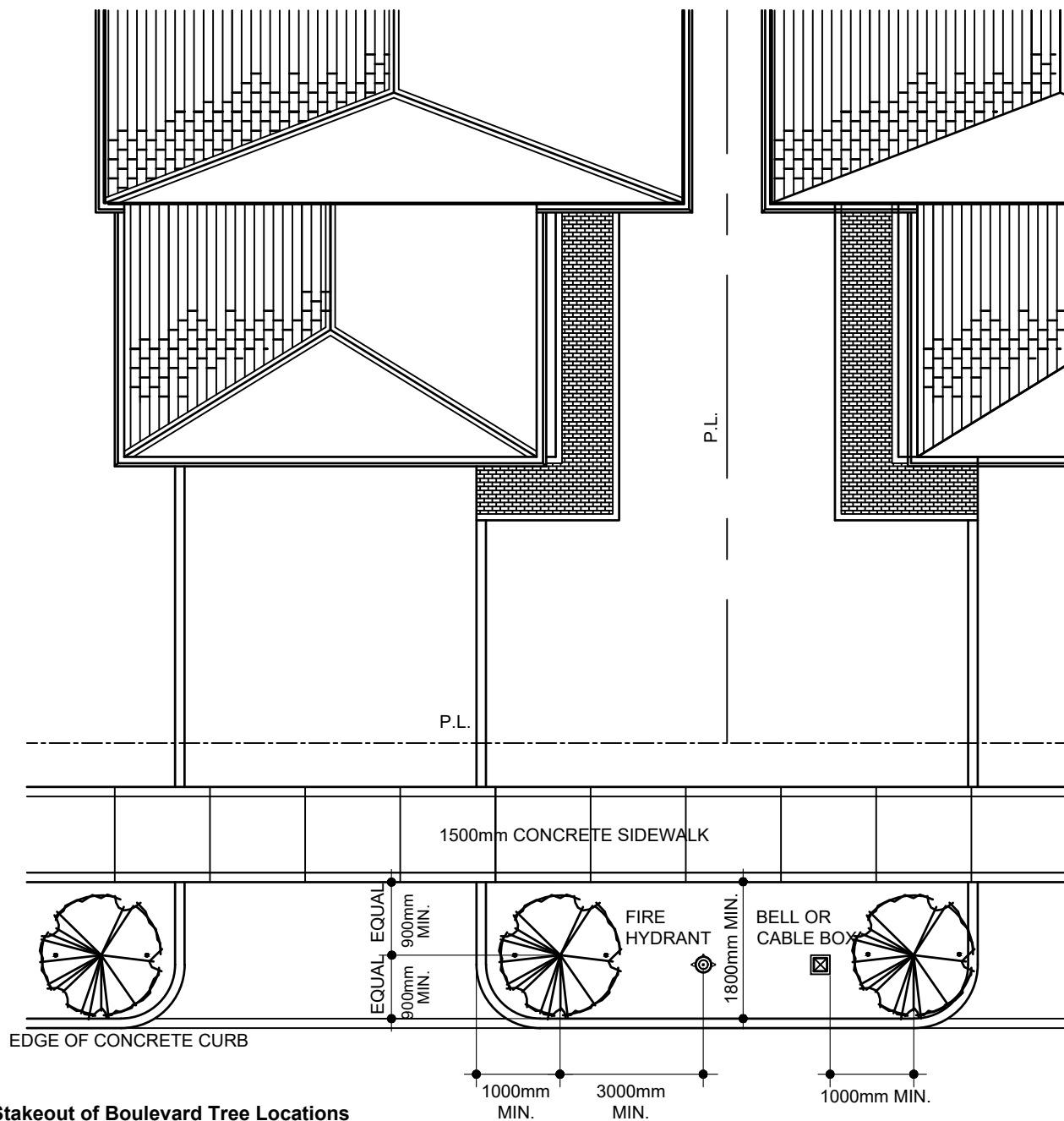

Stakeout of Boulevard Tree Locations

All operations regarding boulevard tree stake out and implementation are to be inspected and certified by the consulting Landscape Architect and City Forestry Representative. The Owner shall ensure all underground utilities (existing and proposed) are staked out prior to the boulevard tree stake out. Please note that Vaughan Hydro has identified specific requirements associated with the location of trees relative to their underground systems.

The following distances are to be ensured in the location of trees within the boulevard:

- * not less than 1.0 metre from underground utilities, surface mounted bell/cable boxes, sidewalks and driveways
- *not less than 3.0 metre from hydrants
- * not less than 0.900 of a metre from underground gas utilities
- * cannot be planted in utility easements

LOCAL ROAD



VAUGHAN

DEVELOPMENT PLANNING DEPT.
URBAN DESIGN DIVISION

BOULEVARD TREE DETAIL
FIRE HYDRANT & UTILITY PEDESTAL
LAYOUT

NOTE: THIS TYPICAL DETAIL IS INTENDED TO PROVIDE DESIGN DIRECTION AND IS FOR REFERENCE ONLY. IT MAY BE USED AS PART OF THE CONSTRUCTION PACKAGE OR SITE PLAN APPLICATION PROVIDED THE DETAIL IS CERTIFIED BY A REGISTERED LANDSCAPE ARCHITECT OR PROFESSIONAL ENGINEER AS APPLICABLE.

DRAWN & DESIGNED: <u>URBAN DESIGN</u>	STD. DWG. NO. <u>ULA 208</u>
NOT TO SCALE DATE: <u>03 / 01 / 2011</u>	

PART 1 - SCOPE

TerraSeeding is the process involving the use of composted topsoil that is injected with seed into a pneumatic blower truck then subsequently blown onto areas designated for the establishment of turf.

PART 2 - MATERIALS

2.1 Seed:

Seed is to be Canada No.1 seed or higher quality

2.2 Seed Mix:

2.2.1 Type 'A' - Custom Meadow Mix:

To be used in all stormpond and valley areas outside 5 year flood line.

Big Blue Stem (Andropogon Gerardii)	25%
Little Blue Stem (Schizachyrum Scoparius)	25%
Fox Sedge (Carex Vulpinoidea)	15%
Canadian Wild Rye (Elymus Canadensis)	25%
Poverty Oat Grass (Danthonia Spicata)	10%

Application seed rate:

200kg / ha

Supplied by:

Ontario Seed Company // tel: 519-886-0557
(or approved equal to be approved by Landscape Architect)

2.2.2 Type 'B' - Custom Wet Meadow Mix:

To be used in all stormpond and valley areas inside 5 year flood line.

Joe Pye Weed (Eupatorium Malculatum)	10%
Canada Bluejoint (Calamagrostis Canadensis)	15%
Fox Sedge (Carex Vulpinoidea)	25%
Soft Rush (Juncus Effusus)	15%
Jointed Rush (Juncus Articulatus)	10%
Porcupine Sedge (Carex Hystericina)	15%
Blue Vervain (Verbena Hastata)	10%

Application seed rate:

200kg / ha

Supplied by:

Ontario Seed Company // tel: 519-886-0557
(or approved equal to be approved by Landscape Architect)

2.3 Annual Nurse Crop Seed

Nurse crop seed shall be a cereal grain such as Fall Rye Grain or Winter Wheat Grain unless otherwise approved by the Contract Administrator.

2.4 Fertilizer

Fertilizer shall comply with the provisions of the Canada Fertilizers Act and Fertilizer Regulations. Fertilizer shall be supplied in original bags bearing the manufacturer's original label indicating mass and analysis. All fertilizer shall be in granular form, dry, free flowing and free from lumps and with an analysis as specified in Table 1 (Page 6).

2.5 Composted Topsoil

Composted topsoil shall be pre-mixed and shall consist of a minimum 60% compost material. The composted topsoil may be amended by the addition of concrete sand and peat loam. Concrete sand shall be added to improve aeration and soil structure. Peat loam shall be added to adjust the pH of the compost and to make the composted topsoil lighter and easier to blow. Both amendments shall be added at the discretion of the Contractor to ensure that the composted topsoil meets the material specification and is suited for distribution by a pneumatic blower.

Once mixed, composted topsoil material shall consist of particles where 100% of the material is able to pass through a 25 mm sieve.

2.6 Compost

Compost shall be derived from well-composted green organic waste matter. All compost material shall meet the Ontario Ministry of the Environment's Interim Guidelines for the Production and Use of Aerobic Compost in Ontario definition for Type A compost and shall be supplied from composting sites certified to meet the Ontario Ministry of the Environment's Compost Regulation 101.

2.7 Concrete Sand

Concrete sand shall have a pH range from 7.7 to 8.0 with a mid-range of 7.8 and shall meet gradation requirements for concrete sand as described in OPSS.

2.8 Peat Loam

Peat loam shall consist of a minimum 50% organic matter and equal parts sand, silt and clay. Peat loam shall be suitable for horticultural purposes. Shredded particles shall not exceed 16 mm in size.

2.9 Water

Water shall be free of any contaminants or impurities that would adversely affect the germination and growth of vegetation.

PART 3 - EQUIPMENT

3.1 Pneumatic Blower Truck

The pneumatic blower truck shall be a custom manufactured, fully integrated, truck-mounted unit. The blower truck shall be equipped with a computer-calibrated seed injection system and shall be capable of uniformly applying composted topsoil and seed at a rate greater than 0.25 cubic meters of material per minute. The blower truck shall also be equipped with an application hose capable of extended 90 meters from the blower truck unit.



VAUGHAN

**DEVELOPMENT PLANNING DEPT.
URBAN DESIGN DIVISION**

TERRASEEDING DETAIL
GENERAL NOTES (1 of 2)

NOTE: THIS TYPICAL DETAIL IS INTENDED TO PROVIDE DESIGN DIRECTION AND IS FOR REFERENCE ONLY. IT MAY BE USED AS PART OF THE CONSTRUCTION PACKAGE OR SITE PLAN APPLICATION PROVIDED THE DETAIL IS CERTIFIED BY A REGISTERED LANDSCAPE ARCHITECT OR PROFESSIONAL ENGINEER AS APPLICABLE.

DRAWN & DESIGNED: <u>URBAN DESIGN</u>	STD. DWG. NO. <u>ULA 211</u>
NOT TO SCALE	DATE: <u>03 / 01 / 2011</u>

PART 4 - CONSTRUCTION

4.1 Operational Constraints

The composted topsoil and seeding operation shall not commence until a legible, valid Seed Analysis Certificate and a legible, valid signed declaration from the compost supplier have been provided to the Contract Administrator.

The composted topsoil and seeding operation shall not commence until the Contract Administrator has approved the surface preparation and the layout of permanent seed mixes.

The composted topsoil and seeding application and/or re-application shall not be carried out under adverse field conditions such as high wind, frozen soil or soil covered with snow, ice or in areas of standing water or a concentrated flow of water.

The Contractor shall maintain the site and control erosion until conditions permit application or re-application of seed and composted topsoil.

The surface to be seeded shall be prepared not more than 7 calendar days before the seeding operation.

No seeding or composted topsoil application shall come in contact with the foliage of any trees, shrubs, or other vegetation.. No seed or composted topsoil application shall come in contact with waterbodies.

4.2 Surface Preparation for Composted Topsoil and Seeding

At the time of seeding, all surface areas designated for seeding shall be free of erosion and shall have a fine graded uniform surface. The surface shall be uniformly cultivated with agricultural implements to a minimum depth of 50 mm and shall not have surface stones greater than 50 mm in diameter, weeds or other unwanted vegetation.

Soil to be loose, friable and suitable as a seed bed to germinate seed.

4.3 Layout

The location of the seed mix and composted topsoil shall be staked out on the ground surface in accordance with the contract drawings. Stakes shall be used to indicate the limits of the seed mix.

4.4 Composted Topsoil and Seeding

4.4.1 Application Rates for Composted Topsoil

Depending on slope gradation, depth of composted soil, seed shall be as follows:

- 0-5% slope: 10-15 mm. depth
- 5-10% slope: 15-20 mm. Depth
- 10-25% slope: (4:1) 20-25 mm. depth
- 25-35% slope: (3:1) 25-40 mm. depth
- 35-45% slope: 40-50 mm. depth

4.4.2 Composted Topsoil and Seed Application

Prior to the application of the composted topsoil and seeding, the Contractor shall ensure that the pneumatic blower has been properly calibrated to provide the specified amounts of seed and that the blower can adequately uniformly apply composted topsoil and seed at a rate greater than 0.25 cubic meters of material per minute.

Once the blower has been calibrated, the Contractor shall apply composted topsoil and seeding uniformly at specified depths to all areas identified for cover in the contract drawings or as directed by the Contract Administrator.

Composted topsoil and seed shall overlap the adjoining ground cover by 300 mm.

4.4.3 Clean-up

At the completion of the seeding and cover operation, materials applied to areas or objects other than those designated to grow grass shall be removed. Clean water shall be used to immediately wash seed or cover materials that have been applied to the foliage of trees, shrubs or other susceptible plant growth.

PART 5 - QUALITY ASSURANCE

5.1 Performance Measure

All composted topsoil and seeded areas will be inspected by the Contract Administrator to ensure compliance with this specification at thirty, sixty and ninety day periods following the composted topsoil and seeding operation.

At the thirty day inspection within the seeded earth area;

- the composted topsoil shall be visually intact and shall form a uniform cohesive mat;
- germination of the nurse crop shall be visually evident.

At the sixty day inspection within the seeded earth area;

- the nurse crop shall be evident at mature height in an evenly dispersed, uniform cover;
- germination of the specified, permanent seed species shall be visually evident in an evenly dispersed uniform cover;
- there shall not be any significant bare areas, both in terms of quantity and size;
- non-seeded, non-specified vegetation shall not exceed 20% of the seeded earth area.

At the ninety day inspection within the seeded earth area;

- the permanent seed species shall be at an average height of 50mm in an evenly dispersed, uniform cover; representative of the specified, permanent seed mixes;
- there shall not be any significant bare areas, both in terms of quantity and size;
- non-seeded, non-specified vegetation shall not exceed 20% of the seeded earth area.

No inspections will be held during the winter dormant period or when site conditions prohibit a visual field inspection. The timing intervals between inspections will be suspended during the winter dormant period.

5.2 Failure to Meet Performance Measure

If the completed work does not meet the Performance Measure after the thirty-day inspection, the Contract Administrator shall document the failure areas, notify the Contractor of those areas, and re-inspect at the sixty day inspection.

If the completed work does not meet the Performance Measure after the sixty or ninety day inspection, the Contract Administrator shall notify the Contractor in writing and the Contractor shall re-apply the specified materials in accordance with this specification within 14 calendar days of receiving the notification.

The Contractor shall maintain the site and control erosion until conditions permit application or re-application of and composted topsoil seed.

All replaced composted topsoil and seed shall be subject to the Quality Assurance section of this specification.

5.3 Measurement and Payment Procedures

Measurement: Measurement shall be based on a lump sum basis.

Payment: Payment shall be based on the lump sum price in the tender.

The tendered price shall constitute full compensation for furnishing and preparation of all materials and equipment as required to complete the work as specified in the Contract Drawings. In addition, the price is to include the cost of all labour as required to complete the above-noted work.

 <div style="margin-left: 10px;"> <h1 style="margin: 0;">VAUGHAN</h1> <p style="margin: 0;">DEVELOPMENT PLANNING DEPT. URBAN DESIGN DIVISION</p> </div>				
<p>TERRASEEDING DETAIL GENERAL NOTES (2 of 2)</p> <p><small>NOTE: THIS TYPICAL DETAIL IS INTENDED TO PROVIDE DESIGN DIRECTION AND IS FOR REFERENCE ONLY. IT MAY BE USED AS PART OF THE CONSTRUCTION PACKAGE OR SITE PLAN APPLICATION PROVIDED THE DETAIL IS CERTIFIED BY A REGISTERED LANDSCAPE ARCHITECT OR PROFESSIONAL ENGINEER AS APPLICABLE.</small></p>				
<table style="width: 100%; border: none;"> <tr> <td style="border: none;">DRAWN & DESIGNED: <u>URBAN DESIGN</u></td> <td style="border: none;">STD. DWG. NO. <u>ULA 212</u></td> </tr> <tr> <td style="border: none;">NOT TO SCALE</td> <td style="border: none;">DATE: <u>03 / 01 / 2011</u></td> </tr> </table>	DRAWN & DESIGNED: <u>URBAN DESIGN</u>	STD. DWG. NO. <u>ULA 212</u>	NOT TO SCALE	DATE: <u>03 / 01 / 2011</u>
DRAWN & DESIGNED: <u>URBAN DESIGN</u>	STD. DWG. NO. <u>ULA 212</u>			
NOT TO SCALE	DATE: <u>03 / 01 / 2011</u>			

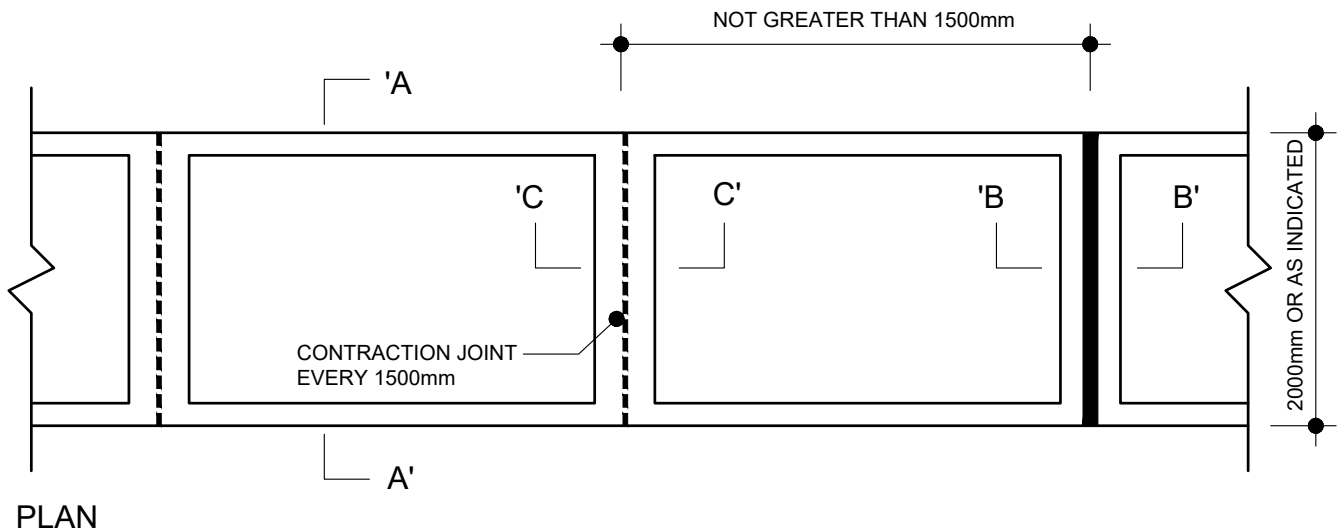

PLAN

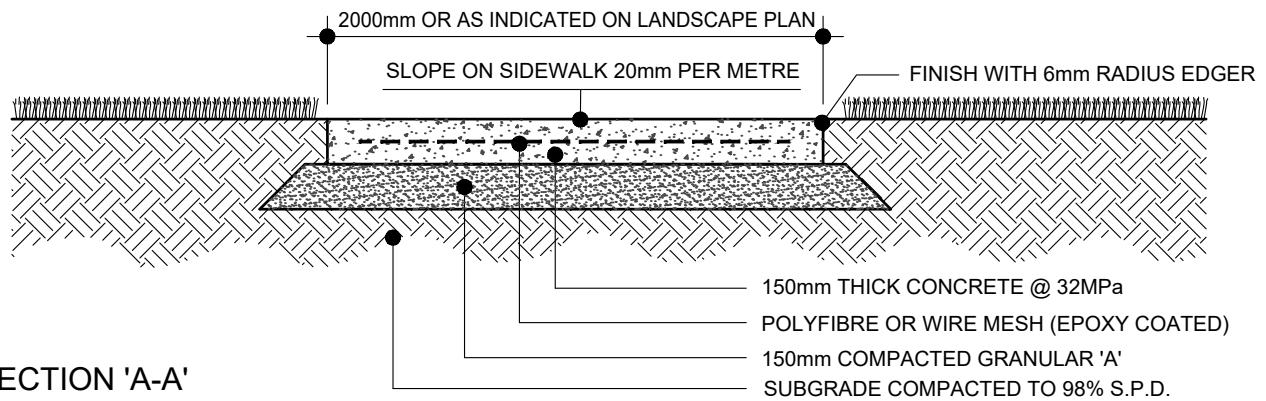

SECTION 'A-A'

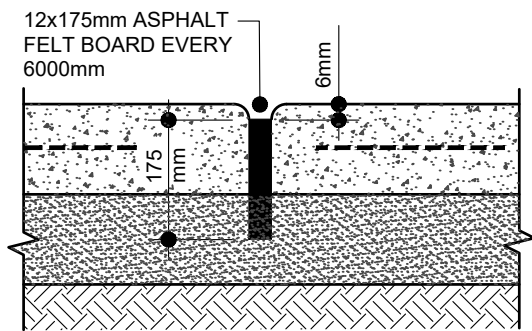

SECTION 'B-B'
EXPANSION JOINT DETAIL

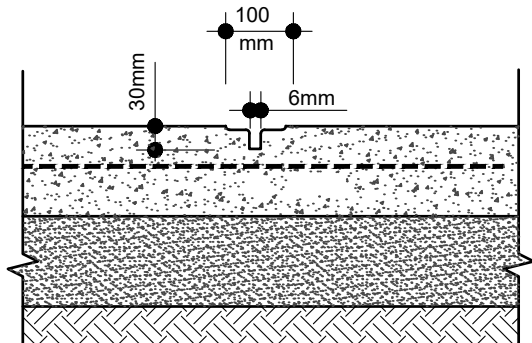

SECTION 'C-C'
CONTRACTION JOINT DETAIL

NOTES:

1. 32MPa Class 'A' concrete max. cement/water ratio 0.5 @ 28 days with 6% air entrainment.
2. Concrete to have broom finish.
3. Expansion joints to be located every 6m and where concrete paving abuts other structures or buildings.
4. Contraction joints to be located at minimum intervals of 1.5m. To be formed with a double edger in fresh concrete, then saw cut to a depth of 30mm.
5. Concrete to be sprayed with white pigment curing compound immediately after finishing.
6. All dimensions are in millimetres.

VAUGHAN
DEVELOPMENT PLANNING DEPT.
URBAN DESIGN DIVISION

**POURED-IN-PLACE CONCRETE
PAVING IN URBAN AREAS DETAIL**

NOTE: THIS TYPICAL DETAIL IS INTENDED TO PROVIDE DESIGN DIRECTION AND IS FOR REFERENCE ONLY. IT MAY BE USED AS PART OF THE CONSTRUCTION PACKAGE OR SITE PLAN APPLICATION PROVIDED THE DETAIL IS CERTIFIED BY A REGISTERED LANDSCAPE ARCHITECT OR PROFESSIONAL ENGINEER AS APPLICABLE.

DRAWN & DESIGNED: URBAN DESIGN

STD. DWG. NO.

NOT TO SCALE DATE: 03 / 01 / 2011

ULA 301

REFER TO LAYOUT PLAN

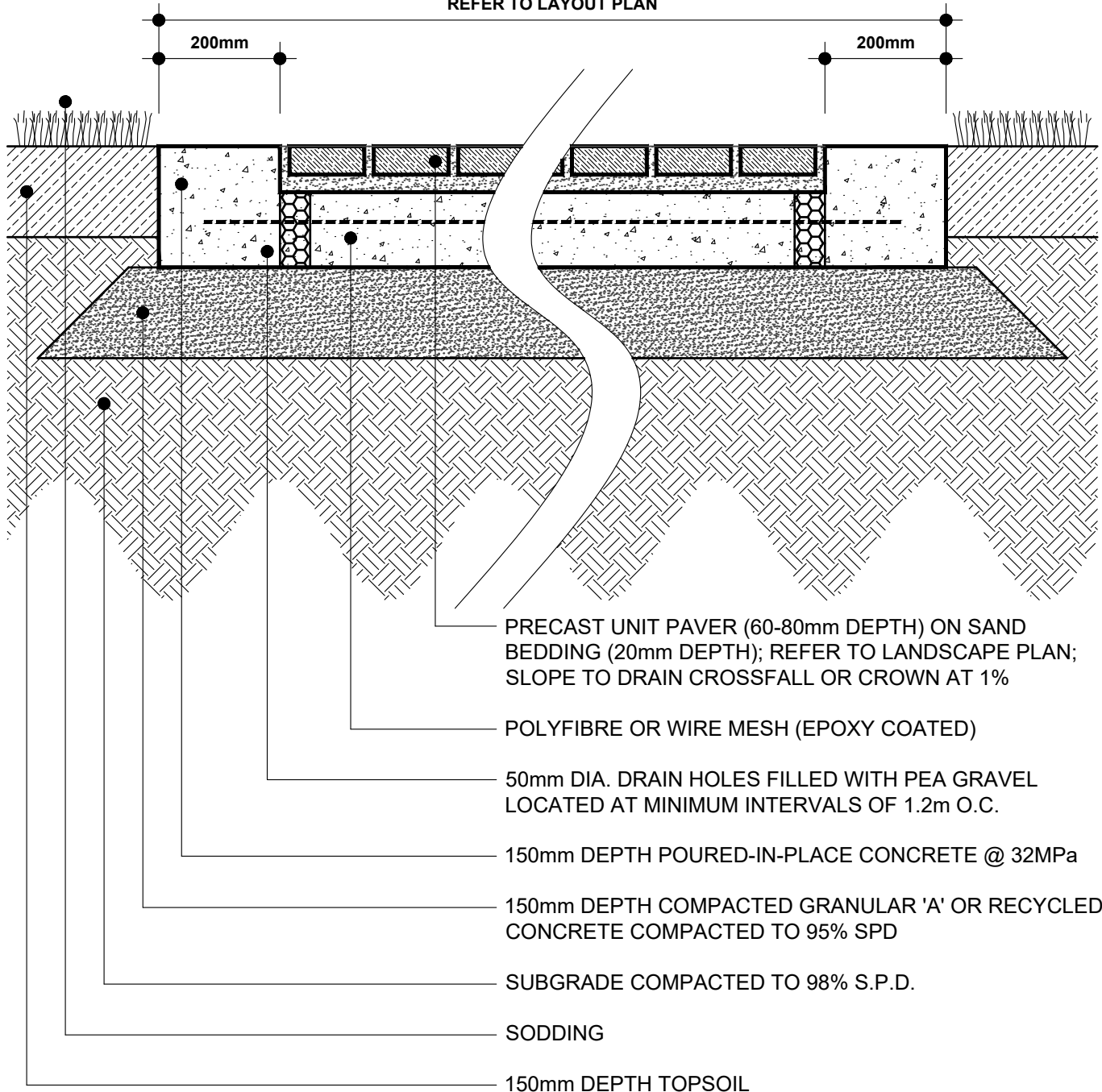

PRECAST UNIT PAVER (60-80mm DEPTH) ON SAND BEDDING (20mm DEPTH); REFER TO LANDSCAPE PLAN; SLOPE TO DRAIN CROSSFALL OR CROWN AT 1%

POLYFIBRE OR WIRE MESH (EPOXY COATED)

50mm DIA. DRAIN HOLES FILLED WITH PEA GRAVEL LOCATED AT MINIMUM INTERVALS OF 1.2m O.C.

150mm DEPTH POURED-IN-PLACE CONCRETE @ 32MPa

150mm DEPTH COMPACTED GRANULAR 'A' OR RECYCLED CONCRETE COMPACTED TO 95% SPD

SUBGRADE COMPACTED TO 98% S.P.D.

SODDING

150mm DEPTH TOPSOIL

NOTES:

1. All dimensions are in millimetres.
2. 32MPa Class 'A' concrete max. cement/water ratio 0.5 @ 28 days with 6% air entrainment.
3. Concrete to have broom finish.
4. Expansion joints to be located every 6.0m O.C. & where concrete paving abuts other structures or buildings.
5. Contraction joints to be located at minimum intervals of 3.0m O.C. To be formed with a double edger in fresh concrete, then saw cut to a depth of 30mm.
6. Concrete to be sprayed with white pigment curing compound immediately after finishing.
7. Granular base dimensions shown are minimum after compaction.
8. Slope subgrade parallel to finished grade (min 2% slope).



VAUGHAN
DEVELOPMENT PLANNING DEPT.
URBAN DESIGN DIVISION

**PRECAST CONCRETE UNIT PAVING
ON POURED-IN-PLACE CONCRETE
BASE DETAIL**

NOTE: THIS TYPICAL DETAIL IS INTENDED TO PROVIDE DESIGN DIRECTION AND IS FOR REFERENCE ONLY. IT MAY BE USED AS PART OF THE CONSTRUCTION PACKAGE OR SITE PLAN APPLICATION PROVIDED THE DETAIL IS CERTIFIED BY A REGISTERED LANDSCAPE ARCHITECT OR PROFESSIONAL ENGINEER AS APPLICABLE.

DRAWN & DESIGNED: URBAN DESIGN
NOT TO SCALE DATE: 03 / 01 / 2011

STD. DWG. NO.
ULA 302

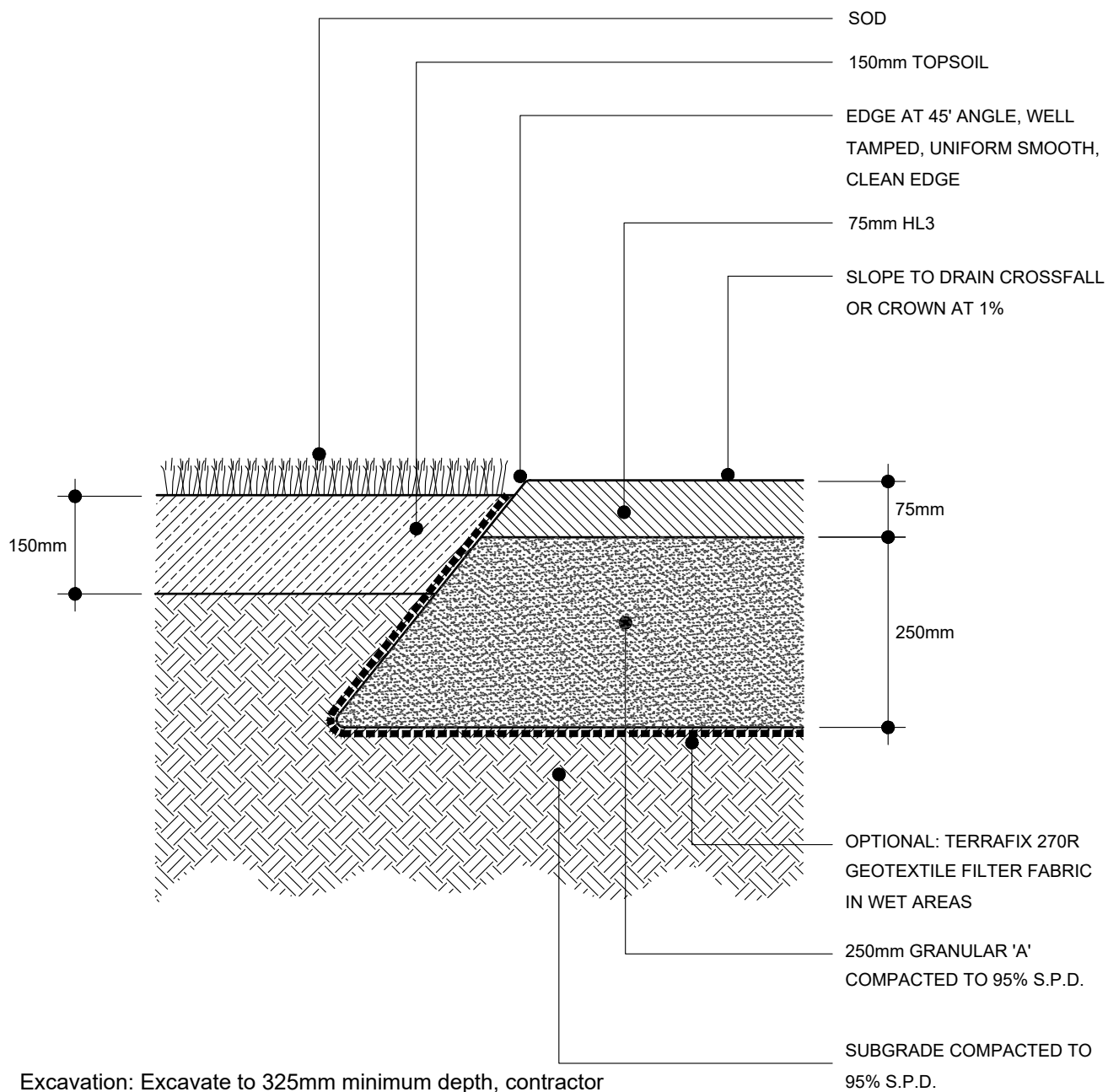

Excavation: Excavate to 325mm minimum depth, contractor shall be responsible for the removal and replacement of any unsuitable subgrade material such as topsoil. Remove all excavated material and dispose of off site.

NOTES:

1. All dimensions in millimetres.
2. Asphalt and granular base dimensions shown are minimum after compaction.
3. Slope subgrade parallel to finished grade (min. 2% slope).
4. Width of path to be identified on landscape plans.



VAUGHAN

DEVELOPMENT PLANNING DEPT.
URBAN DESIGN DIVISION

ASPHALT PAVING (HEAVY-DUTY)
DETAIL

NOTE: THIS TYPICAL DETAIL IS INTENDED TO PROVIDE DESIGN DIRECTION AND IS FOR REFERENCE ONLY. IT MAY BE USED AS PART OF THE CONSTRUCTION PACKAGE OR SITE PLAN APPLICATION PROVIDED THE DETAIL IS CERTIFIED BY A REGISTERED LANDSCAPE ARCHITECT OR PROFESSIONAL ENGINEER AS APPLICABLE.

DRAWN & DESIGNED: <u>URBAN DESIGN</u>	STD. DWG. NO. <u>ULA 303</u>
NOT TO SCALE DATE: <u>03 / 01 / 2011</u>	

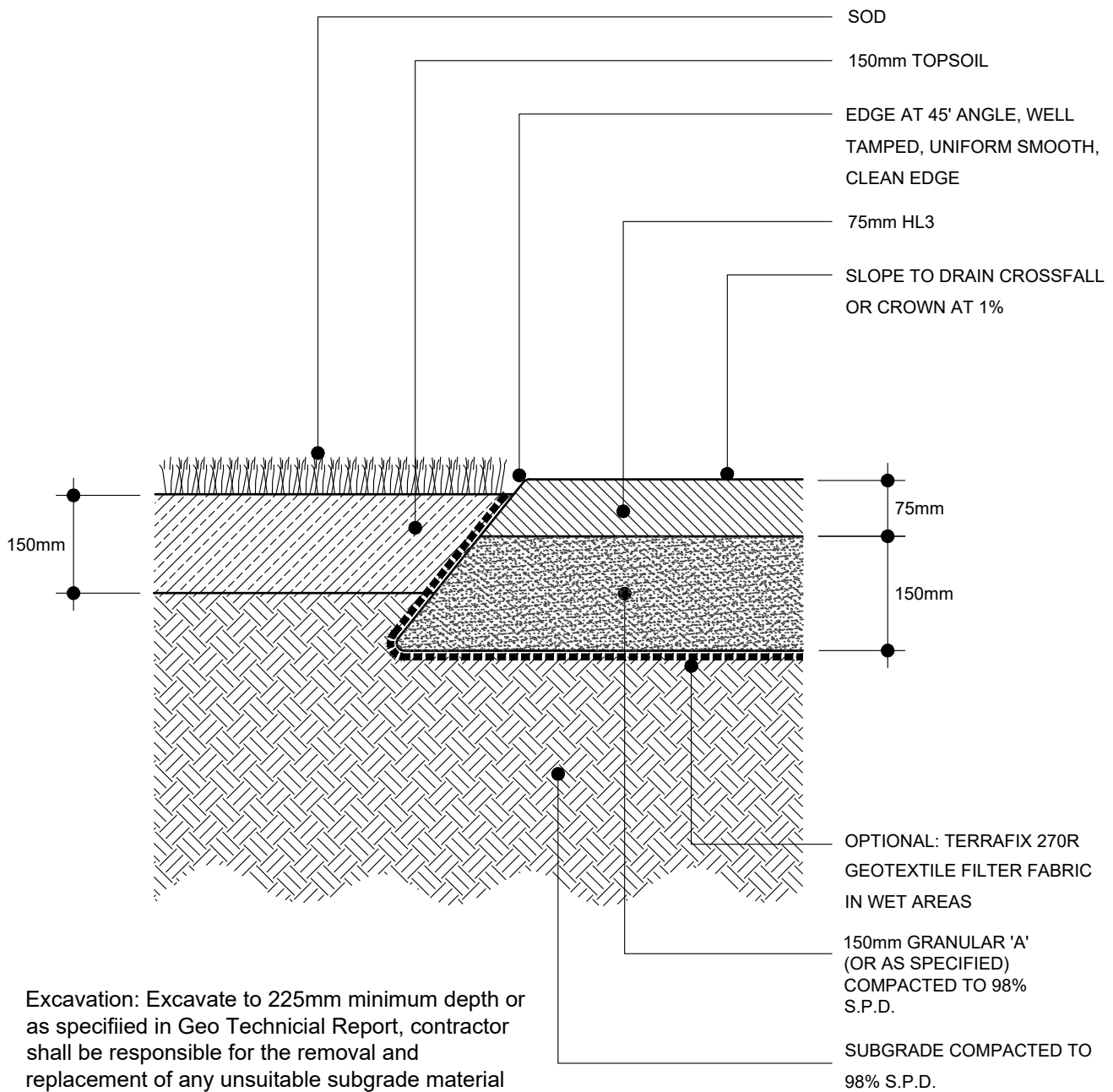

Excavation: Excavate to 225mm minimum depth or as specified in Geo Technical Report, contractor shall be responsible for the removal and replacement of any unsuitable subgrade material such as topsoil. Remove all excavated material and dispose of off site.

NOTES:

1. All dimensions in millimetres.
2. Asphalt and granular base dimensions shown are minimum after compaction.
3. Slope subgrade parallel to finished grade (min. 2% slope).
4. Width of path to be identified on landscape plans.



VAUGHAN

DEVELOPMENT PLANNING DEPT.
URBAN DESIGN DIVISION

ASPHALT PAVING (LIGHT-DUTY)
DETAIL

NOTE: THIS TYPICAL DETAIL IS INTENDED TO PROVIDE DESIGN DIRECTION AND IS FOR REFERENCE ONLY. IT MAY BE USED AS PART OF THE CONSTRUCTION PACKAGE OR SITE PLAN APPLICATION PROVIDED THE DETAIL IS CERTIFIED BY A REGISTERED LANDSCAPE ARCHITECT OR PROFESSIONAL ENGINEER AS APPLICABLE.

DRAWN & DESIGNED: <u>URBAN DESIGN</u>	STD. DWG. NO. <u>ULA 304</u>
NOT TO SCALE	DATE: <u>03 / 01 / 2011</u>

LIMESTONE SCREENINGS TO BE COMBINED WITH AN ENVIRONMENTALLY FRIENDLY ORGANIC BINDER COMPOUND/AGENT; I.E. PERMEABLE & STABILIZED SURFACE THAT RESISTS EROSION WHILE INCREASING THE PAVING SURFACE'S STABILITY AND RESILIENCY.

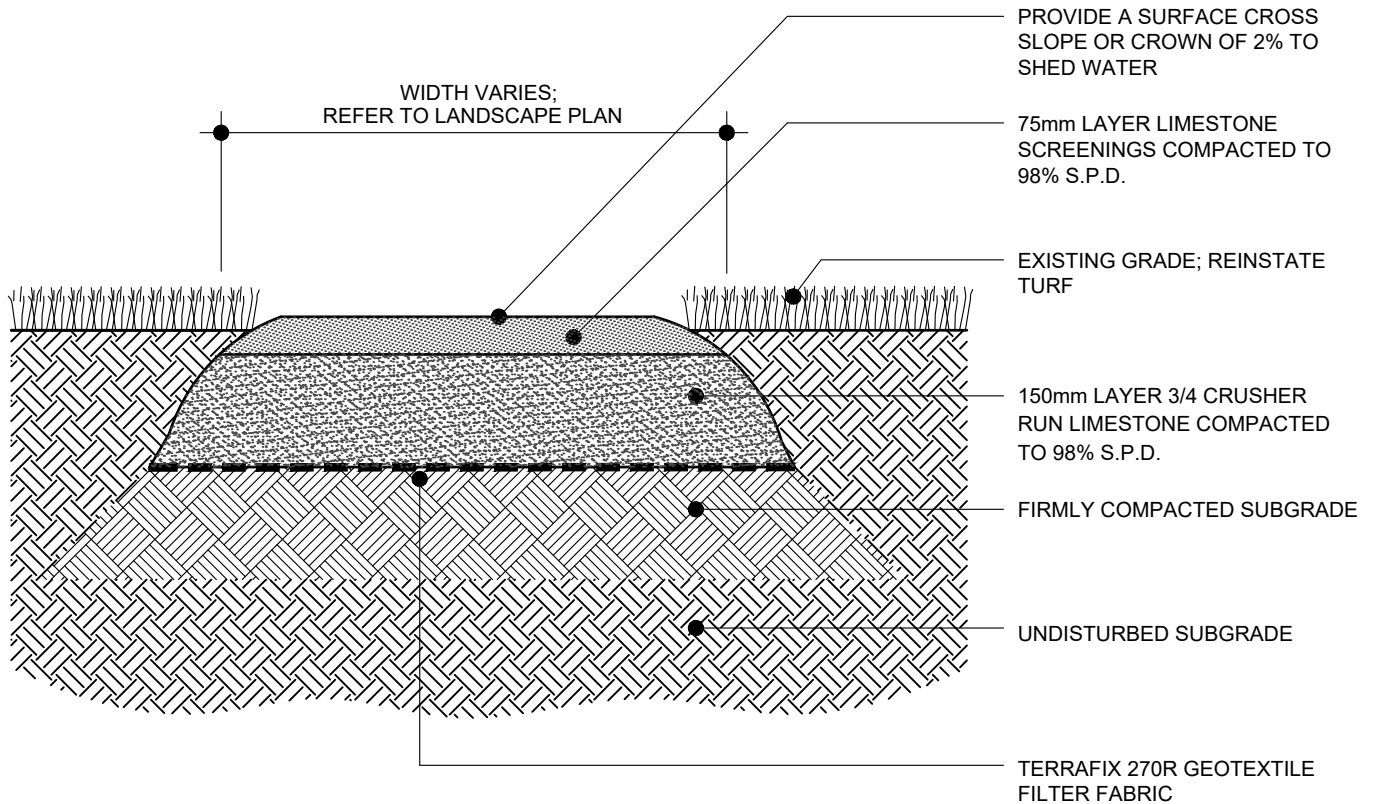

NOTES:

1. Restore all damage to existing sod. Sod laid at trail edge to be placed 25mm below the tread on level ground or on the downhill side of a cross slope. Sod laid on the uphill side of a cross slope to be level with the tread of the walkway to ensure positive drainage.
2. All dimensions in millimetres.
3. Refer to landscape plans for path width.



VAUGHAN
DEVELOPMENT PLANNING DEPT.
URBAN DESIGN DIVISION

LIMESTONE SCREENING PAVING
DETAIL

NOTE: THIS TYPICAL DETAIL IS INTENDED TO PROVIDE DESIGN DIRECTION AND IS FOR REFERENCE ONLY. IT MAY BE USED AS PART OF THE CONSTRUCTION PACKAGE OR SITE PLAN APPLICATION PROVIDED THE DETAIL IS CERTIFIED BY A REGISTERED LANDSCAPE ARCHITECT OR PROFESSIONAL ENGINEER AS APPLICABLE.

DRAWN & DESIGNED: URBAN DESIGN

STD. DWG. NO.

NOT TO SCALE DATE: 03 / 01 / 2011

ULA 305

FLUSH CURB

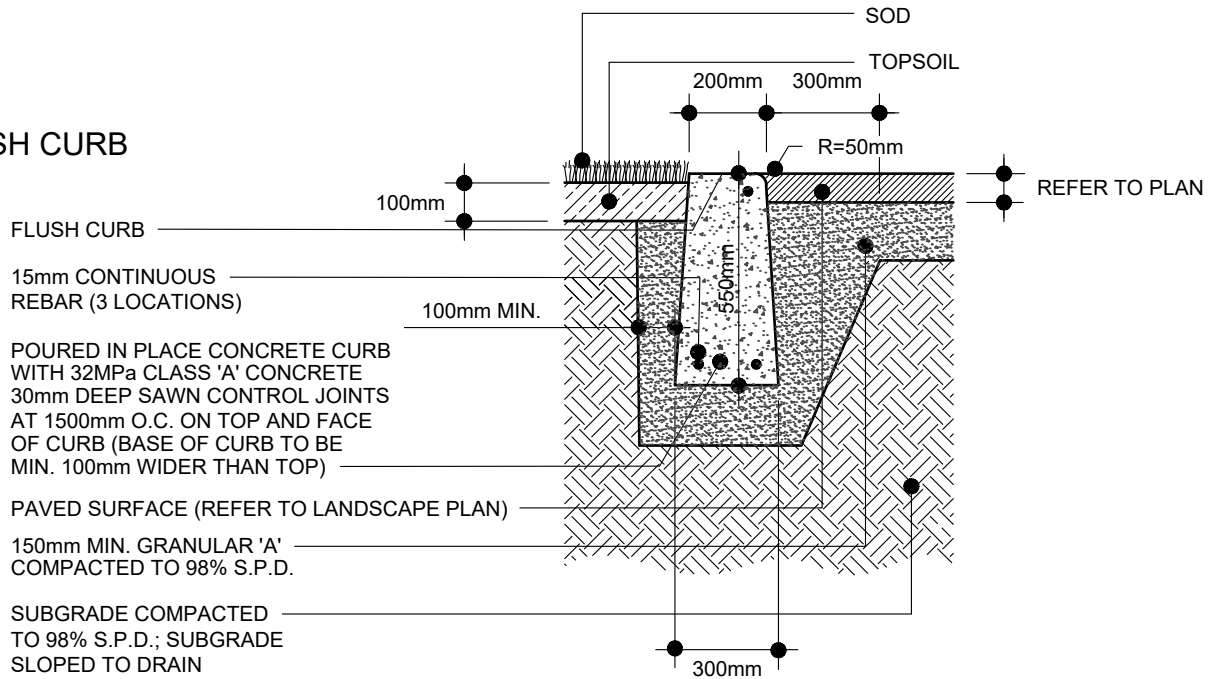

RAISED CURB

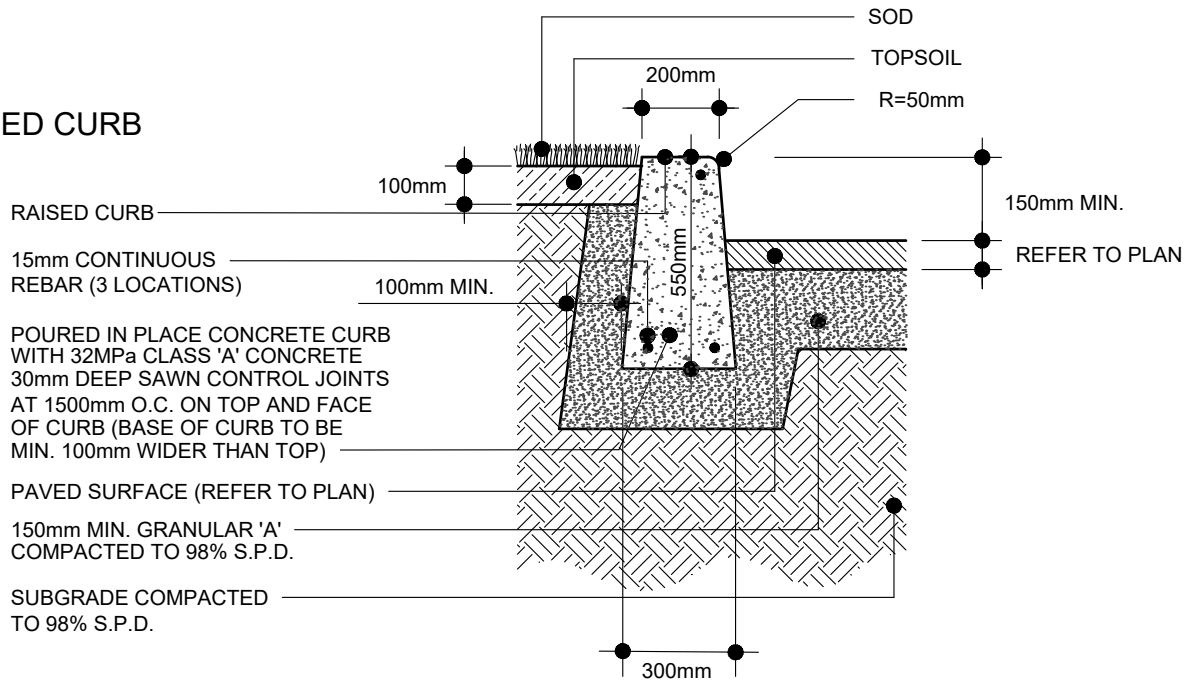

NOTES:

1. All dimensions in millimetres.
2. Asphalt and granular base dimensions shown are minimum after compaction.
3. Slope subgrade parallel to finished grade.
4. Raised curb; drainage of paved surface to be accommodated (ie. area drain or swale).



VAUGHAN

DEVELOPMENT PLANNING DEPT.
URBAN DESIGN DIVISION

POURED-IN-PLACE CONCRETE CURB (RAISED AND FLUSH) DETAIL

NOTE: THIS TYPICAL DETAIL IS INTENDED TO PROVIDE DESIGN DIRECTION AND IS FOR REFERENCE ONLY. IT MAY BE USED AS PART OF THE CONSTRUCTION PACKAGE OR SITE PLAN APPLICATION PROVIDED THE DETAIL IS CERTIFIED BY A REGISTERED LANDSCAPE ARCHITECT OR PROFESSIONAL ENGINEER AS APPLICABLE.

DRAWN & DESIGNED: URBAN DESIGN

STD. DWG. NO.

NOT TO SCALE DATE: 03 / 01 / 2011

ULA 306

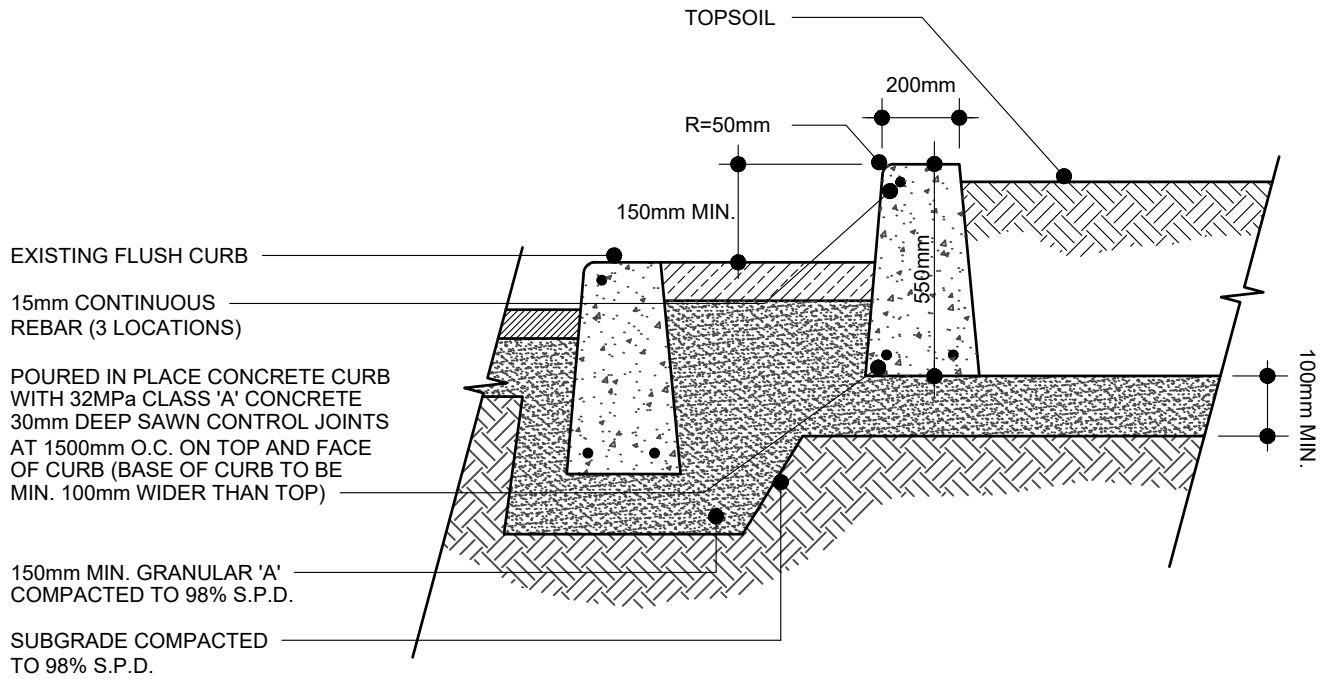

VAUGHAN
DEVELOPMENT PLANNING DEPT.
URBAN DESIGN DIVISION

**POURED-IN-PLACE CONCRETE CURB
(TRAFFIC MEDIAN PLANTING BED)
DETAIL**

NOTE: THIS TYPICAL DETAIL IS INTENDED TO PROVIDE DESIGN DIRECTION AND IS FOR REFERENCE ONLY. IT MAY BE USED AS PART OF THE CONSTRUCTION PACKAGE OR SITE PLAN APPLICATION PROVIDED THE DETAIL IS CERTIFIED BY A REGISTERED LANDSCAPE ARCHITECT OR PROFESSIONAL ENGINEER AS APPLICABLE.

DRAWN & DESIGNED: URBAN DESIGN

STD. DWG. NO.

NOT TO SCALE DATE: 03 / 01 / 2011

ULA 307

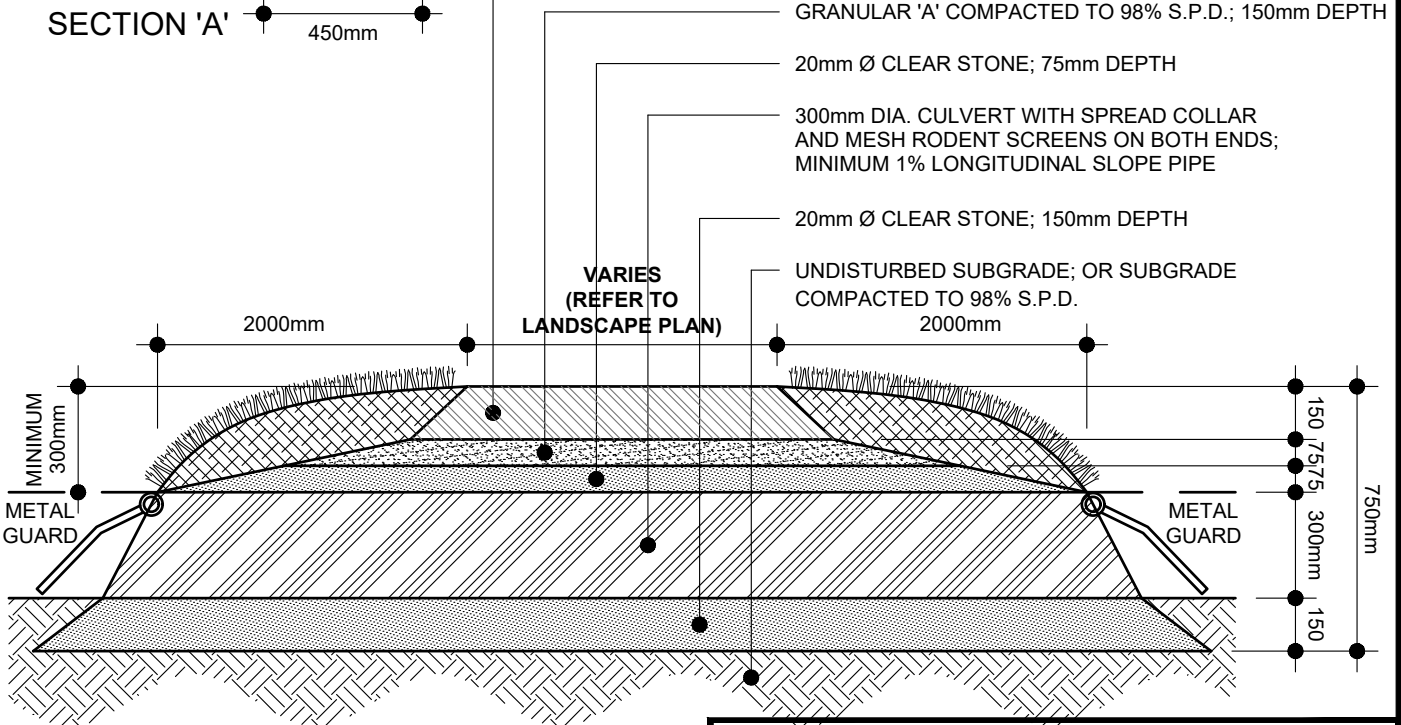
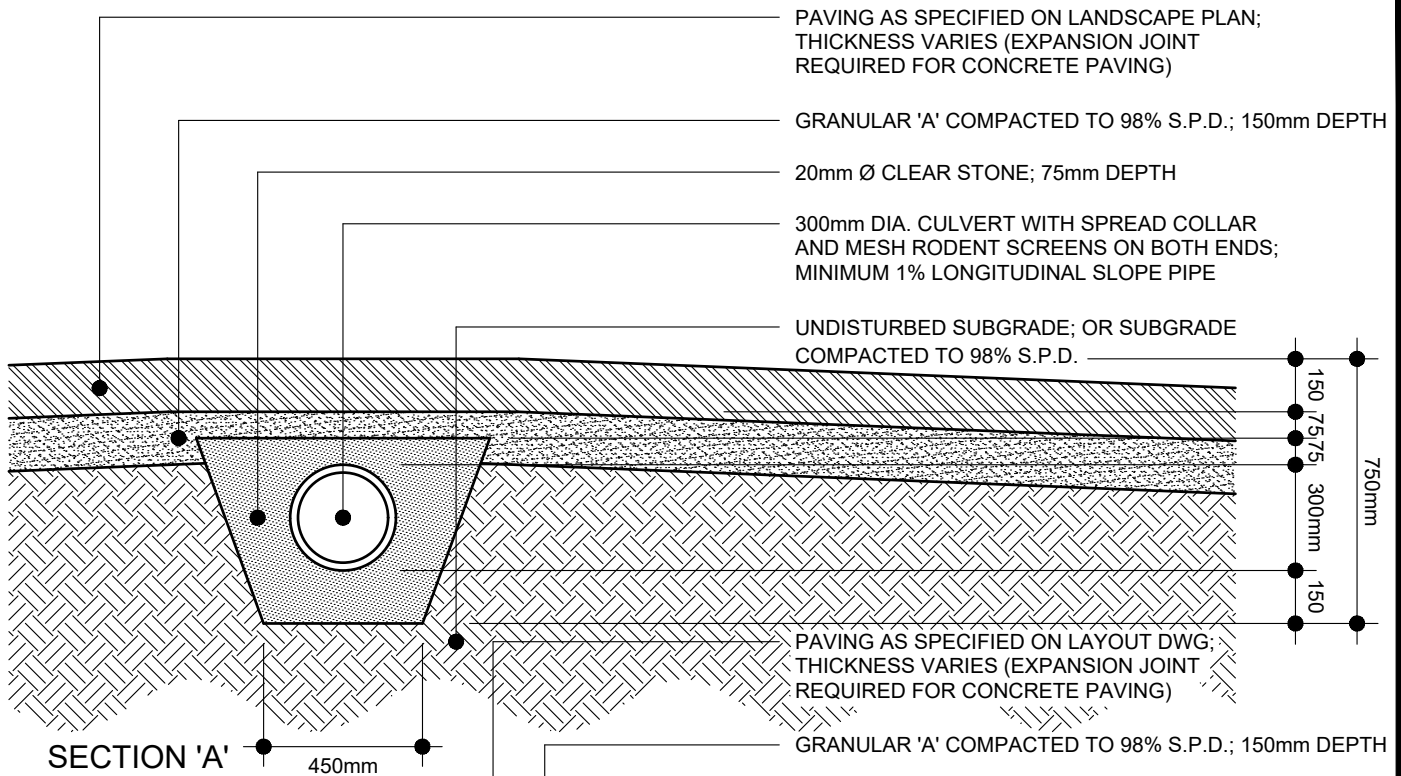

SECTION 'B'

NOTES:

1. Contractor to provide 2 metal culvert guards for both culvert ends.
2. All dimensions in millimetres.



VAUGHAN
DEVELOPMENT PLANNING DEPT.
URBAN DESIGN DIVISION

CULVERT
DETAIL

NOTE: THIS TYPICAL DETAIL IS INTENDED TO PROVIDE DESIGN DIRECTION AND IS FOR REFERENCE ONLY. IT MAY BE USED AS PART OF THE CONSTRUCTION PACKAGE OR SITE PLAN APPLICATION PROVIDED THE DETAIL IS CERTIFIED BY A REGISTERED LANDSCAPE ARCHITECT OR PROFESSIONAL ENGINEER AS APPLICABLE.

DRAWN & DESIGNED: URBAN DESIGN
NOT TO SCALE DATE: 03 / 01 / 2011

STD. DWG. NO.
ULA 308

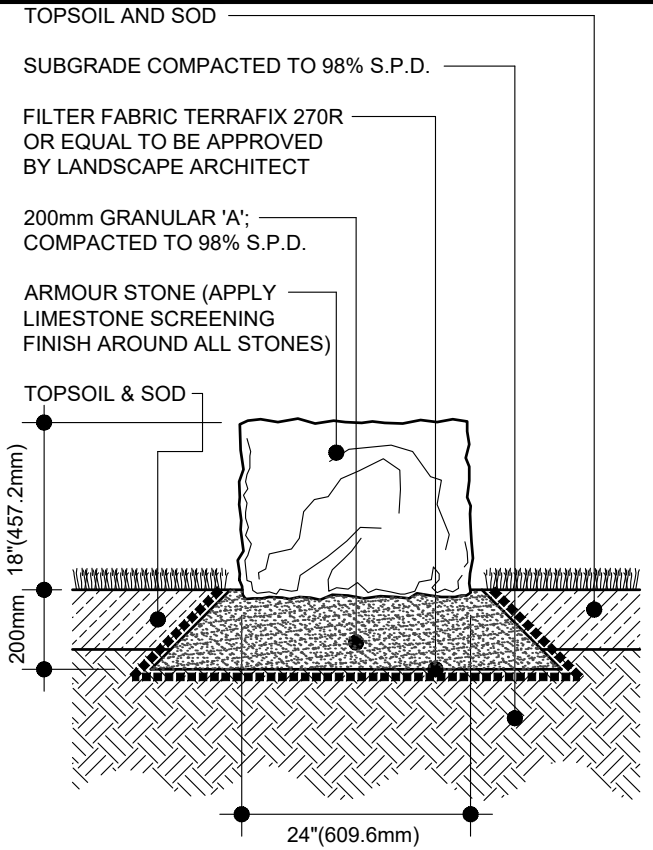

SECTION 'A' - ARMOUR STONE WITH SOD

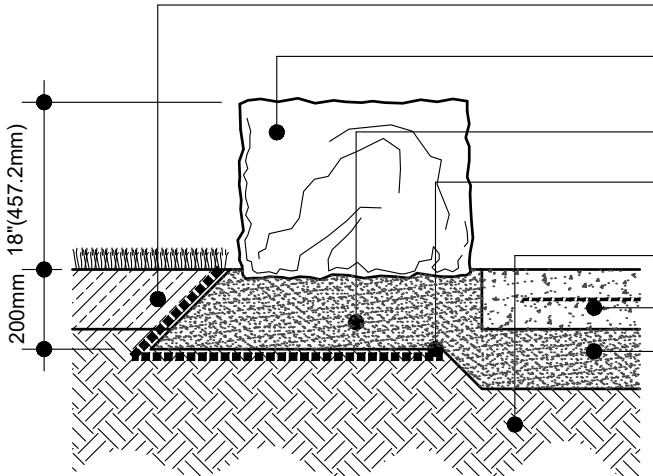

SECTION 'B' - ARMOUR STONE WITH P-I-P CONCRETE SIDEWALK

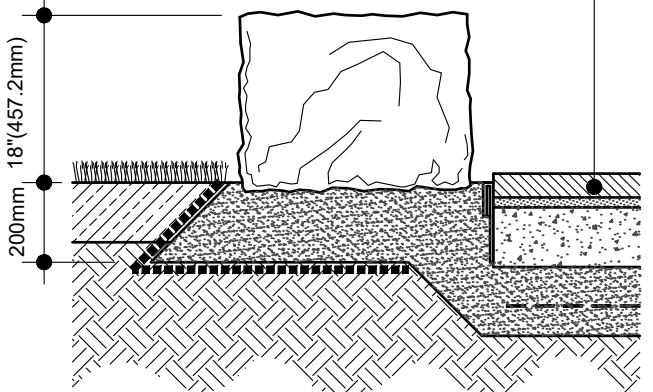

SECTION 'C' - ARMOUR STONE WITH PRECAST CONCRETE UNIT PAVING

NOTES:

1. All stones to be approved by Landscape Architect prior to installation.
2. All quarry stone to have split or naturally weathered faces; no exposed drill markings.

PLAN VIEW

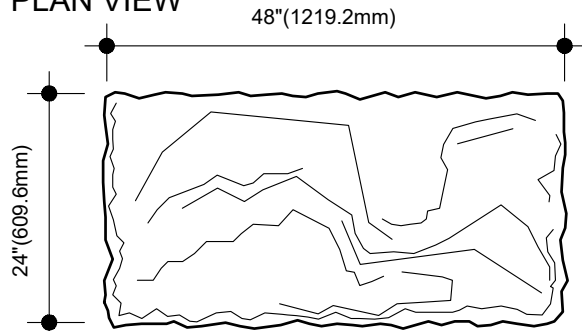

ELEVATION

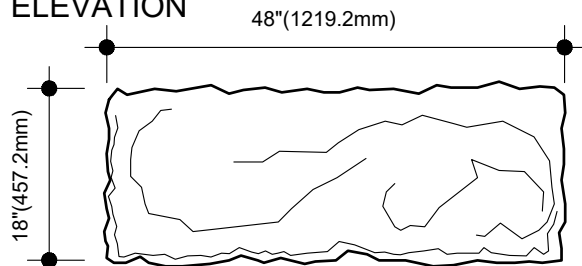

- TOPSOIL AND SOD
- ARMOUR STONE (APPLY LIMESTONE SCREENING FINISH AROUND ALL STONES)
- 200mm GRANULAR 'A'; COMPACTED TO 98% S.P.D.
- FILTER FABRIC TERRAFIX 270R OR EQUAL TO BE APPROVED BY LANDSCAPE ARCHITECT
- SUBGRADE COMPACTED TO 98% S.P.D.
- 150mm THICK CONCRETE SIDEWALK @32MPa WITH POLYFIBRE; ON 150mm GRANULAR 'A' BASE, COMPACTED TO 95% S.P.D. (REFER TO MLA 202)
- 60mm PRECAST CONCRETE PAVER (SINGLE SOLDIER COURSE OR OTHER, AS PER LAYOUT PLAN); ON 20mm (OR 25mm) MORTAR SETTING BED & EDGER; ON 150mm THICK CONCRETE @32MPa (OPTIONAL USE; AS PER LAYOUT PLAN & MLA 201); ON 150mm GRANULAR 'A' BASE COMPACTED TO 98% S.P.D.; WITH ALUMINUM EDGE RESTRAINT (REFER TO MLA 201)

VAUGHAN

DEVELOPMENT PLANNING DEPT.
URBAN DESIGN DIVISION

ARMOUR STONE
DETAIL

NOTE: THIS TYPICAL DETAIL IS INTENDED TO PROVIDE DESIGN DIRECTION AND IS FOR REFERENCE ONLY. IT MAY BE USED AS PART OF THE CONSTRUCTION PACKAGE OR SITE PLAN APPLICATION PROVIDED THE DETAIL IS CERTIFIED BY A REGISTERED LANDSCAPE ARCHITECT OR PROFESSIONAL ENGINEER AS APPLICABLE.

DRAWN & DESIGNED: URBAN DESIGN

NOT TO SCALE DATE: 03 / 01 / 2011

STD. DWG. NO. ULA 309

PLAN VIEW

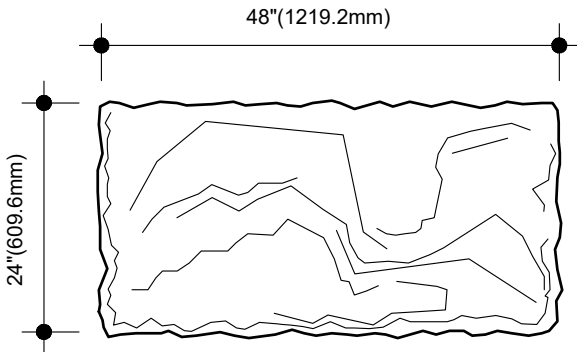

ELEVATION

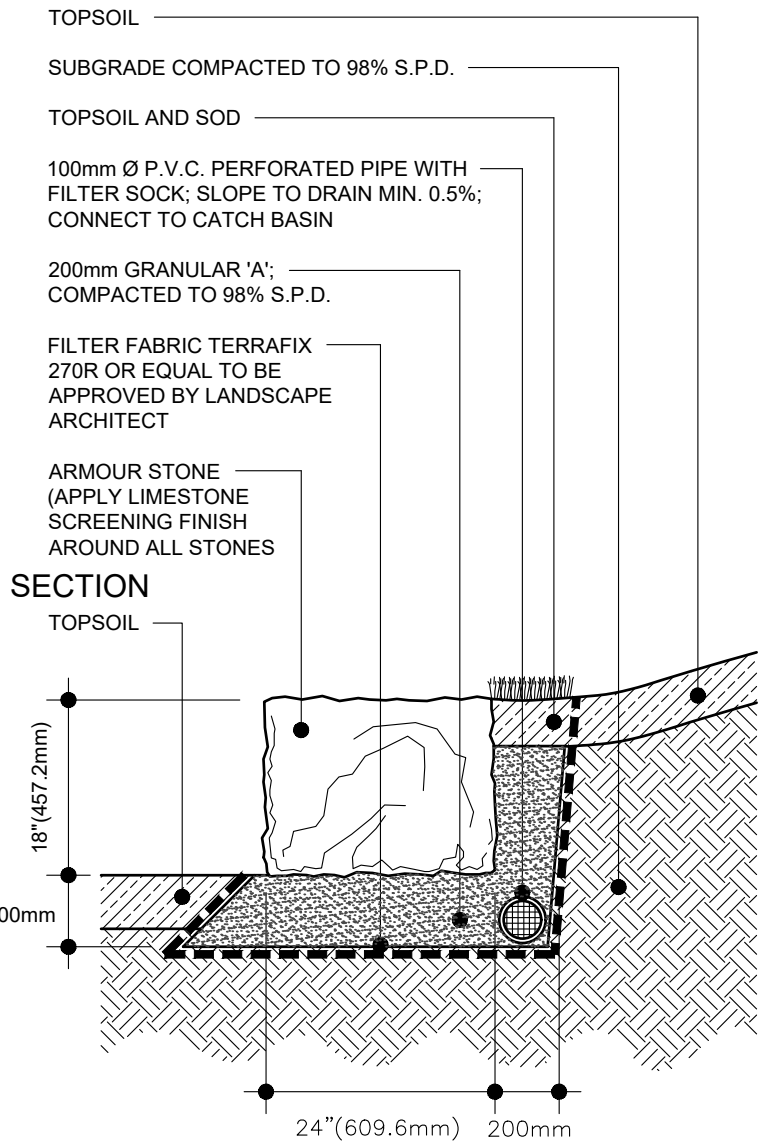
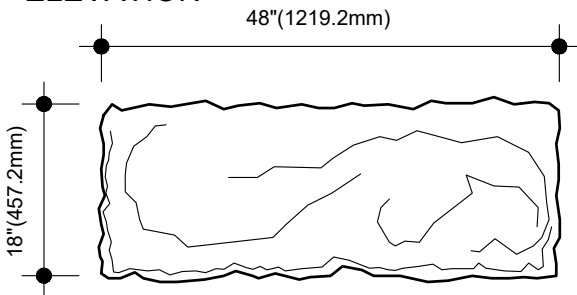

NOTES:

1. All stones to be approved by Landscape Architect prior to installation.
2. All quarry stone to have split or naturally weathered faces; no exposed drill markings.

**ARMOUR STONE
RETAINING WALL DETAIL**

NOTE: THIS TYPICAL DETAIL IS INTENDED TO PROVIDE DESIGN DIRECTION AND IS FOR REFERENCE ONLY. IT MAY BE USED AS PART OF THE CONSTRUCTION PACKAGE OR SITE PLAN APPLICATION PROVIDED THE DETAIL IS CERTIFIED BY A REGISTERED LANDSCAPE ARCHITECT OR PROFESSIONAL ENGINEER AS APPLICABLE.

DRAWN & DESIGNED: URBAN DESIGN

STD. DWG. NO.

NOT TO SCALE DATE: 03 / 01 / 2011

ULA 310

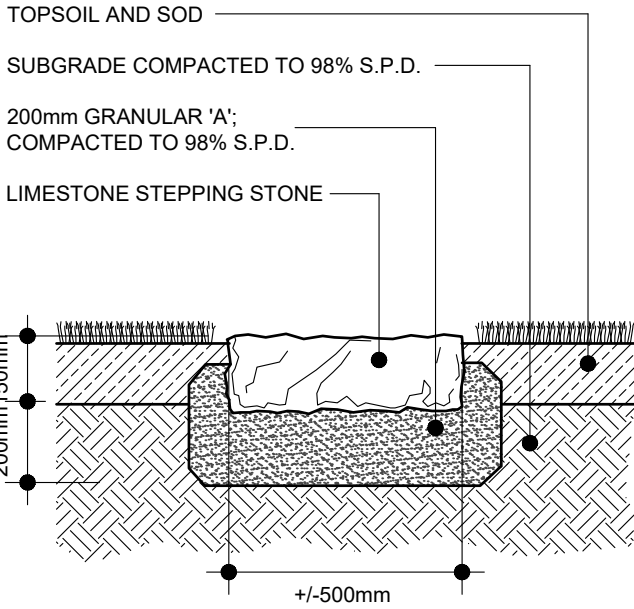

SECTION 'A' - STEPPING STONE IN SOD

NOTES:

1. All stones to be approved by Landscape Architect prior to installation.
2. Tread surface of stones to have natural or bush hammer finish

PLAN VIEW

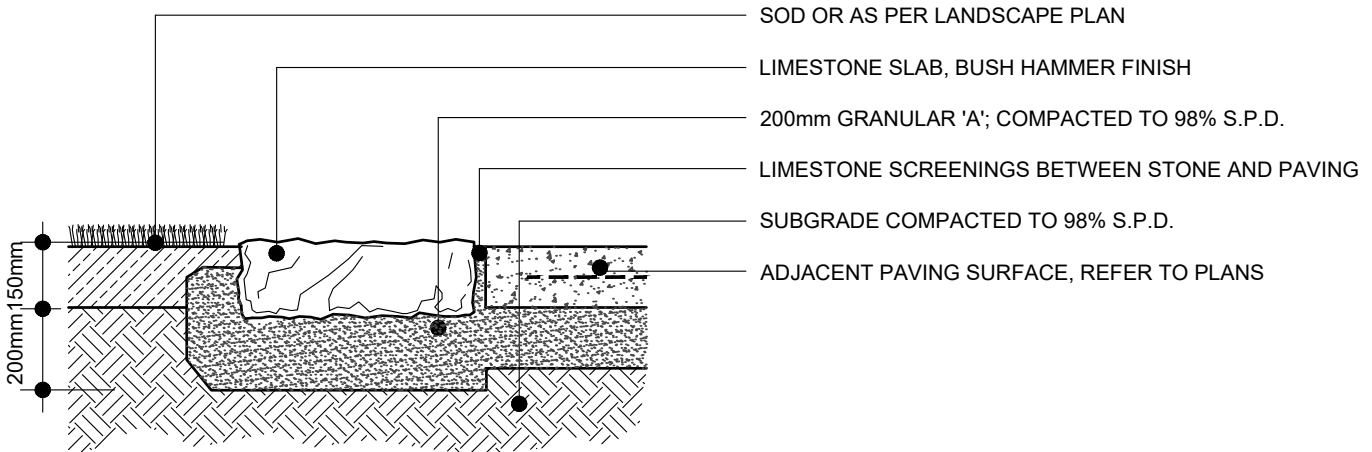
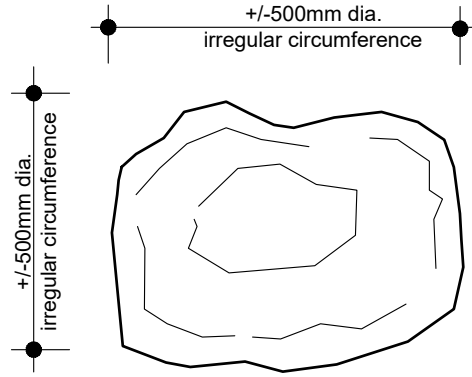

SECTION 'B' - STEPPING STONE
ADJACENT WALKWAY

VAUGHAN
DEVELOPMENT PLANNING DEPT.
URBAN DESIGN DIVISION

ARMOUR STONE
EDGER DETAIL

NOTE: THIS TYPICAL DETAIL IS INTENDED TO PROVIDE DESIGN DIRECTION AND IS FOR REFERENCE ONLY. IT MAY BE USED AS PART OF THE CONSTRUCTION PACKAGE OR SITE PLAN APPLICATION PROVIDED THE DETAIL IS CERTIFIED BY A REGISTERED LANDSCAPE ARCHITECT OR PROFESSIONAL ENGINEER AS APPLICABLE.

DRAWN & DESIGNED: URBAN DESIGN
NOT TO SCALE DATE: 03 / 01 / 2011

STD. DWG. NO.
ULA 311

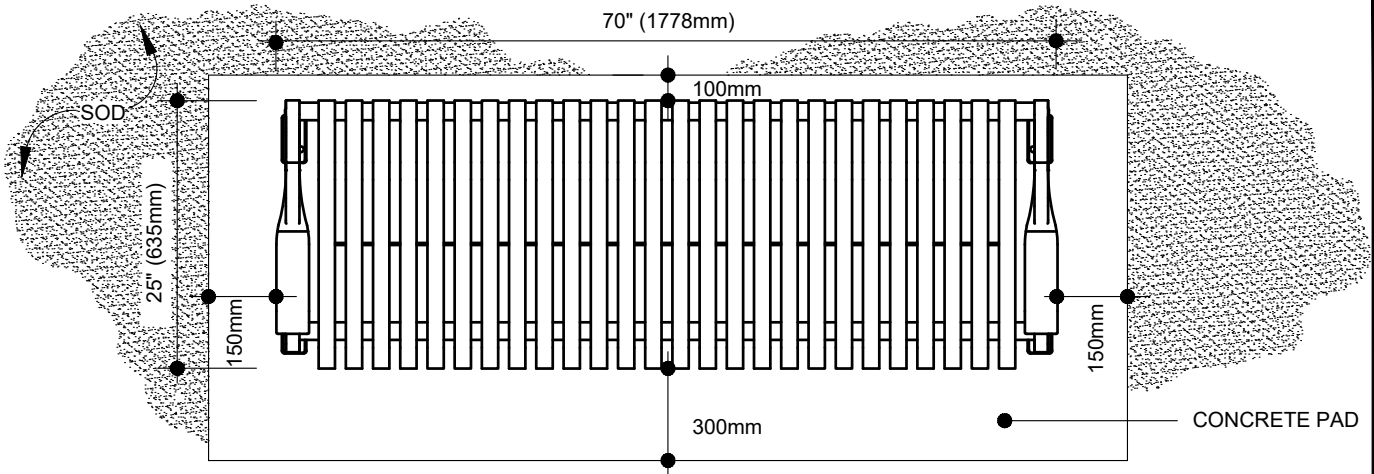

PLAN VIEW

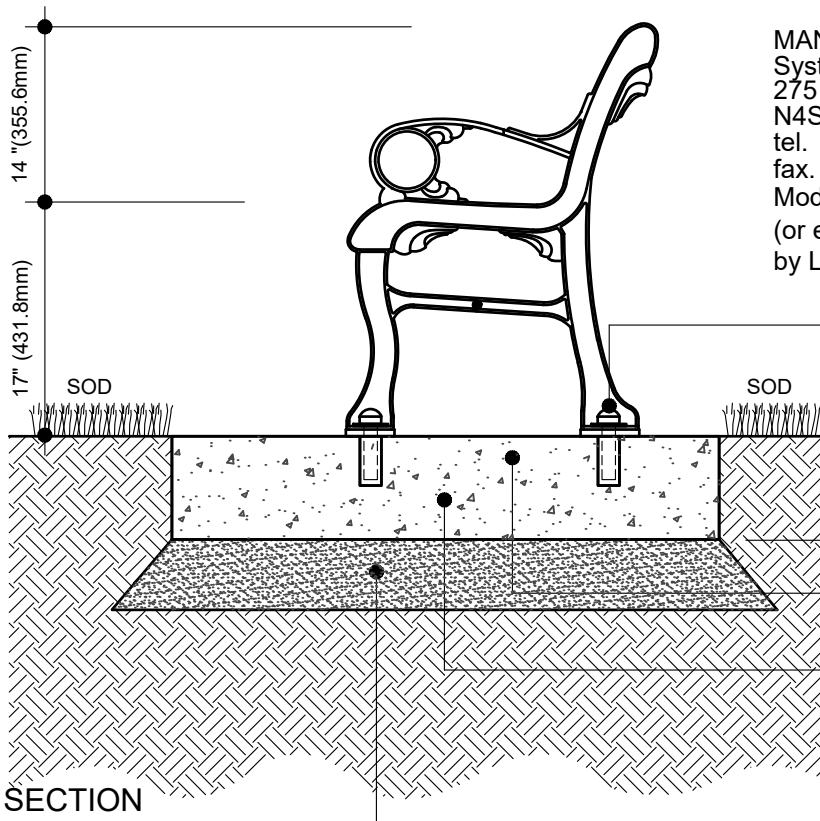

SECTION

MANUFACTURER: Maglin Furniture Systems Ltd
 275 Tecumseh St., Woodstock, On.
 N4S 7W1
 tel. 1 800 716 5506
 fax. 1 877 260 9393
 Model type: MLB315M (6'-0")
 (or equal to be approved by Landscape Architect)

BENCH TO BE SECURED WITH TAMPER PROOF BOLTS (QUANTITY 4)

10mm (3/8") DIA. HILTI HIT EPOXY ANCHORS (QUANTITY 4)

150mm THICK CONCRETE @ 32MPa; MAX. CEMENT / WATER RATIO 0.5% AT 28 DAYS; 6% AIR ENTRAINMENT; CONCRETE PAD OR INTEGRAL POUR WITH CONCRETE PAVING; REFER TO MLA 202

150mm GRANULAR 'A' COMPACTED TO 98% S.P.D.

NOTES:

1. All dimensions in millimetres.
2. All furniture locations to be staked out and/or approved by the Landscape Architect.
3. All sod repairs are the responsibility of the contractor.
4. Colour to be black or as specified by the Landscape Architect.

VAUGHAN
 DEVELOPMENT PLANNING DEPT.
 URBAN DESIGN DIVISION

METAL BENCH (DECORATIVE)
 DETAIL

NOTE: THIS TYPICAL DETAIL IS INTENDED TO PROVIDE DESIGN DIRECTION AND IS FOR REFERENCE ONLY. IT MAY BE USED AS PART OF THE CONSTRUCTION PACKAGE OR SITE PLAN APPLICATION PROVIDED THE DETAIL IS CERTIFIED BY A REGISTERED LANDSCAPE ARCHITECT OR PROFESSIONAL ENGINEER AS APPLICABLE.

DRAWN & DESIGNED: URBAN DESIGN

STD. DWG. NO.

NOT TO SCALE DATE: 03 / 01 / 2011

ULA 401

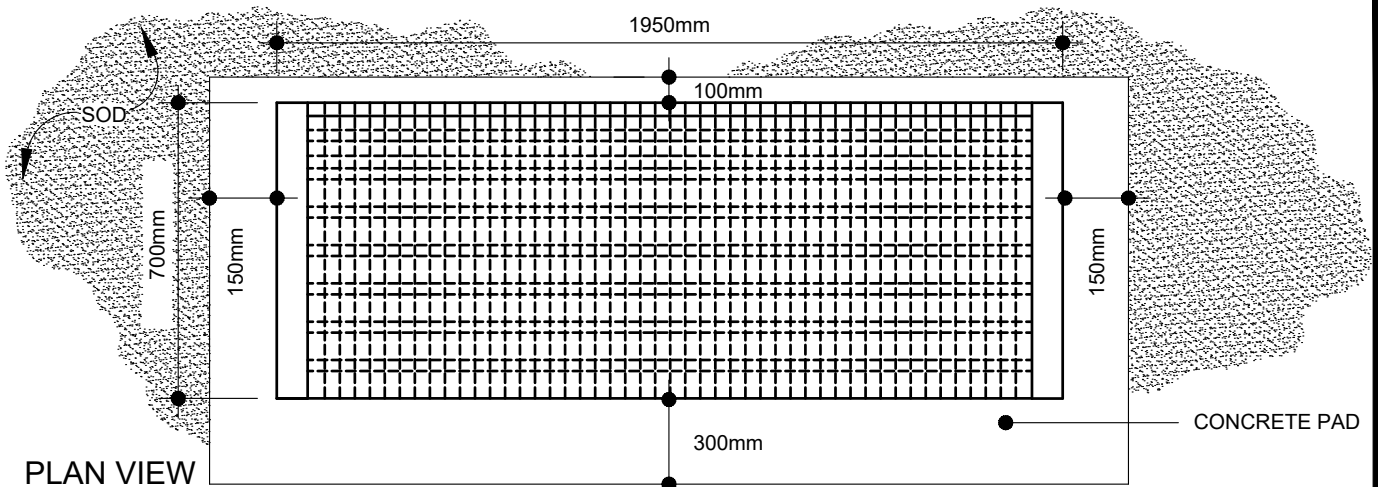

PLAN VIEW

MANUFACTURER: Trystan
 68 Swan St., Ayr, Ont.
 NOB 1E0
 tel. 1-519-632-7427
 fax. 1-519-632-8271
 Model type: TTM-7
 (or equal to be approved
 by Landscape Architect)

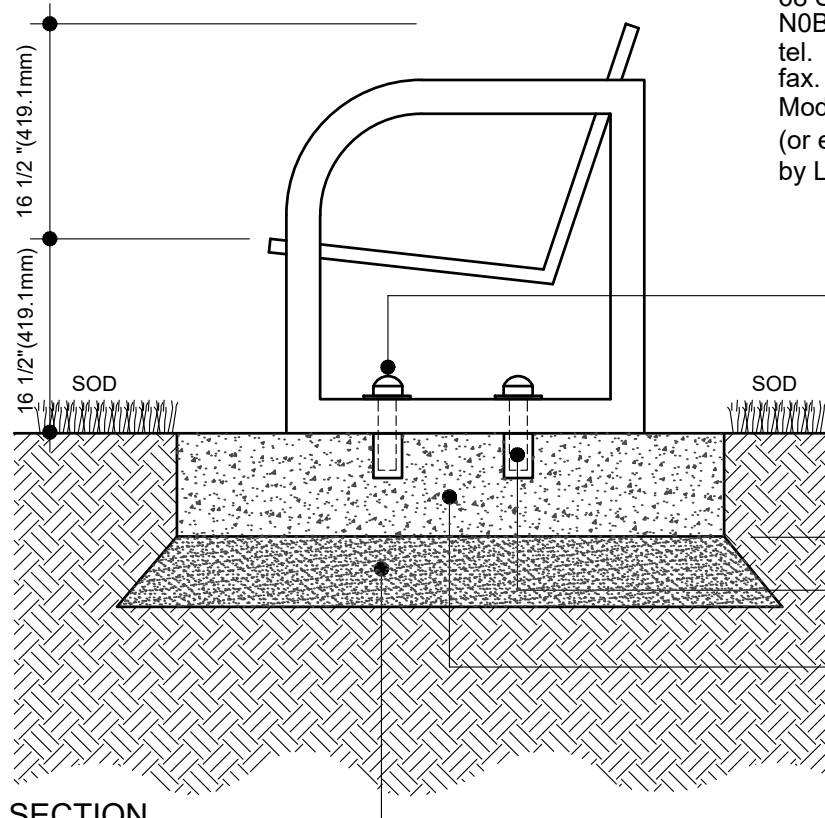

SECTION

BENCH TO BE SECURED WITH
 TAMPER PROOF BOLTS (QUANTITY 4)

10mm (3/8") DIA. HILTI HIT
 EPOXY ANCHORS (QUANTITY 4)

150mm THICK CONCRETE @ 28MPa;
 MAX. CEMENT / WATER RATIO 0.5% AT
 28 DAYS; 6% AIR ENTRAINMENT;
 CONCRETE PAD OR INTEGRAL POUR WITH
 CONCRETE PAVING; REFER TO MLA 202

150mm GRANULAR 'A' COMPACTED TO
 98% S.P.D.

NOTES:

1. All dimensions in millimetres.
2. All furniture locations to be staked out and/or approved by the Landscape Architect.
3. All sod repairs are the responsibility of the contractor.

VAUGHAN
 DEVELOPMENT PLANNING DEPT.
 URBAN DESIGN DIVISION

METAL BENCH
 DETAIL

NOTE: THIS TYPICAL DETAIL IS INTENDED TO PROVIDE DESIGN DIRECTION AND IS FOR REFERENCE ONLY. IT MAY BE USED AS PART OF THE CONSTRUCTION PACKAGE OR SITE PLAN APPLICATION PROVIDED THE DETAIL IS CERTIFIED BY A REGISTERED LANDSCAPE ARCHITECT OR PROFESSIONAL ENGINEER AS APPLICABLE.

DRAWN & DESIGNED: URBAN DESIGN

STD. DWG. NO.

NOT TO SCALE DATE: 03 / 01 / 2011

ULA 402

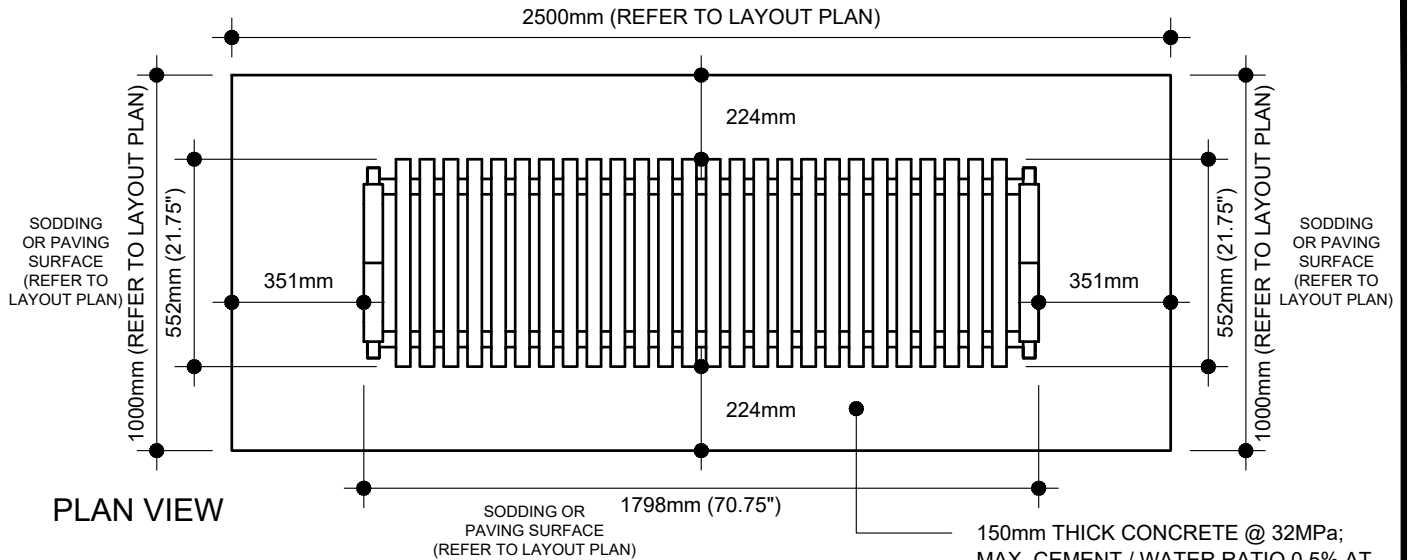

PLAN VIEW

SODDING OR PAVING SURFACE (REFER TO LAYOUT PLAN)

150mm THICK CONCRETE @ 32MPa; MAX. CEMENT / WATER RATIO 0.5% AT 28 DAYS; 6% AIR ENTRAINMENT; CONCRETE PAD.

MANUFACTURER:
 Maglin Furniture Systems Ltd
 27 Bysham Park Dr., Woodstock, On. N4T 1P1
 tel. 1 800 716 5506
 fax. 1 877 260 9393
 Model type: MLB305BM (6'-0")
 (or equal to be approved by Landscape Architect)

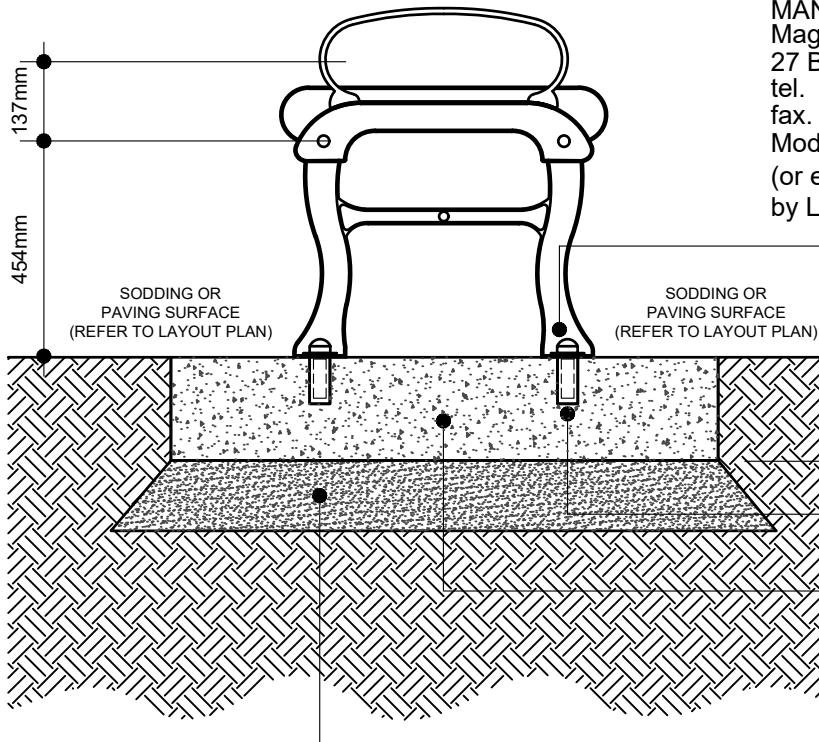

SECTION ELEVATION

BENCH TO BE SECURED WITH TAMPER PROOF BOLTS (QUANTITY 4)

150mm
 10mm (3/8") DIA. HILTI HIT EPOXY ANCHORS (QUANTITY 4)

150mm THICK CONCRETE @ 32MPa; MAX. CEMENT / WATER RATIO 0.5% AT 28 DAYS; 6% AIR ENTRAINMENT; CONCRETE PAD OR INTEGRAL POUR WITH CONCRETE PAVING (REFER TO MLA 202)

150mm GRANULAR 'A' BASE COMPACTED TO 98% S.P.D.

NOTES:

1. All dimensions in millimetres.
2. All furniture locations to be staked out and/or approved by the Landscape Architect.
3. All sod repairs are the responsibility of the contractor.
4. Colour to be black or as specified by Landscape Architect.

VAUGHAN
 DEVELOPMENT PLANNING DEPT.
 URBAN DESIGN DIVISION

METAL BENCH
 (DECORATIVE BACKLESS)
 DETAIL

NOTE: THIS TYPICAL DETAIL IS INTENDED TO PROVIDE DESIGN DIRECTION AND IS FOR REFERENCE ONLY. IT MAY BE USED AS PART OF THE CONSTRUCTION PACKAGE OR SITE PLAN APPLICATION PROVIDED THE DETAIL IS CERTIFIED BY A REGISTERED LANDSCAPE ARCHITECT OR PROFESSIONAL ENGINEER AS APPLICABLE.

DRAWN & DESIGNED: URBAN DESIGN

STD. DWG. NO.

NOT TO SCALE DATE: 03 / 01 / 2011

ULA 403

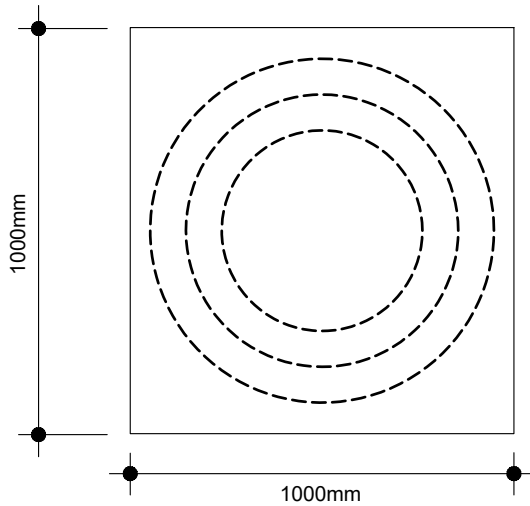

PLAN VIEW

TRASH RECEPTACLE
 AS MANUFACTURE BY:
 Maglin Furnishing Systems Ltd
 275 Techumseh St., Woodstock, Ont.
 Canada, N4S 7W1
 tel. 1-800-716-5506.
 faxl. 1-877-260 9393.
 Model Type: MLWR 200-32SO
 Black, With Side Opening
 (or equal to be approved
 by Landscape Architect)

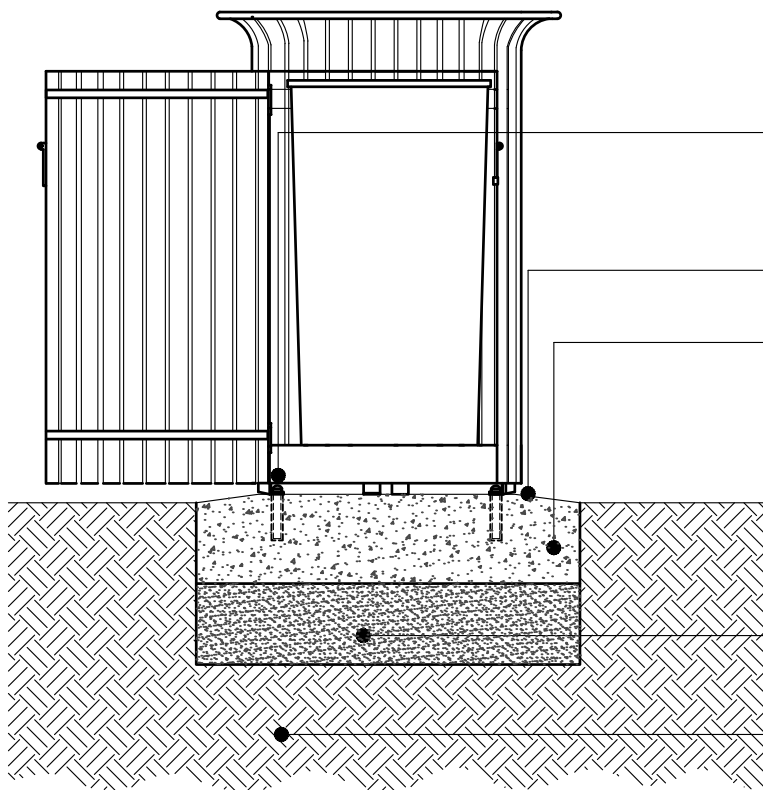

ANCHOR BASE OF WASTE RECEPTACLE USING
 100mm LONG x 67mm DIA. TAMPER PROOF
 BOLTS AND LAG SHIELDS TO CONCRETE AS PER
 MANUFACTURER'S INSTALLATION SPECIFICATIONS

SLOPE TO DRAIN

150mm THICK CONCRETE SLAB OR
 INTEGRAL POUR WITH CONCRETE PAVING;
 CONCRETE TO BE 32MPa CLASS 'A' CONCRETE;
 MAX. CEMENT / WATER RATIO 0.5% AT 28 DAYS;
 6% AIR ENTRAINMENT;
 EXPANSION JOINTS TO BE LOCATED EVERY
 6000mm AND WHERE CONCRETE PAVING
 ABUTS OTHER STRUCTURES OR BUILDINGS

150mm GRANULAR 'A' COMPACTED TO
 98% S.P.D.

UNDISTURBED OR SUBGRADE COMPACTED
 TO 98% S.P.D.

ELEVATION

NOTES:

1. All dimensions in millimetres.
2. All furniture locations to be staked out and/or approved by the Landscape Architect.
3. No lid, heavy-duty metal liner with weep holes at base for drainage.
4. Set waste receptacle in centre of concrete pad.

VAUGHAN
 DEVELOPMENT PLANNING DEPT.
 URBAN DESIGN DIVISION

METAL LITTER RECEPTACLE
 (LARGE SIZE)
 DETAIL

NOTE: THIS TYPICAL DETAIL IS INTENDED TO PROVIDE DESIGN DIRECTION AND IS FOR REFERENCE ONLY. IT MAY BE USED AS PART OF THE CONSTRUCTION PACKAGE OR SITE PLAN APPLICATION PROVIDED THE DETAIL IS CERTIFIED BY A REGISTERED LANDSCAPE ARCHITECT OR PROFESSIONAL ENGINEER AS APPLICABLE.

DRAWN & DESIGNED: URBAN DESIGN

STD. DWG. NO.

NOT TO SCALE DATE: 03 / 01 / 2011

ULA 404

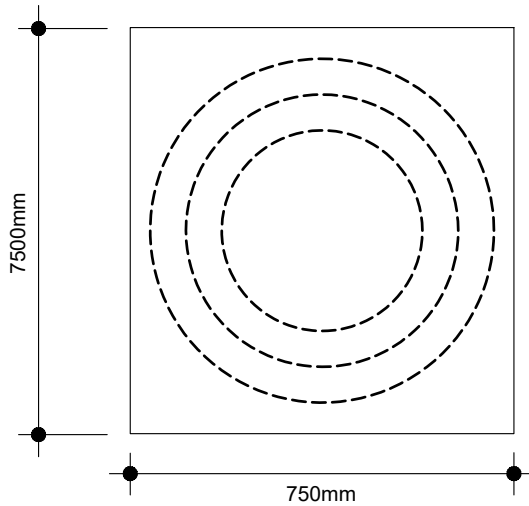

PLAN VIEW

TRASH RECEPTACLE
 AS MANUFACTURE BY:
 Maglin Furnishing Systems Ltd
 275 Techumseh St., Woodstock, Ont.
 Canada, N4S 7W1
 tel. 1-800-716-5506.
 faxl. 1-877-260 9393.
 Model Type: MLWR 200-20SO
 Black, With Side Opening
 (or equal to be approved
 by Landscape Architect)

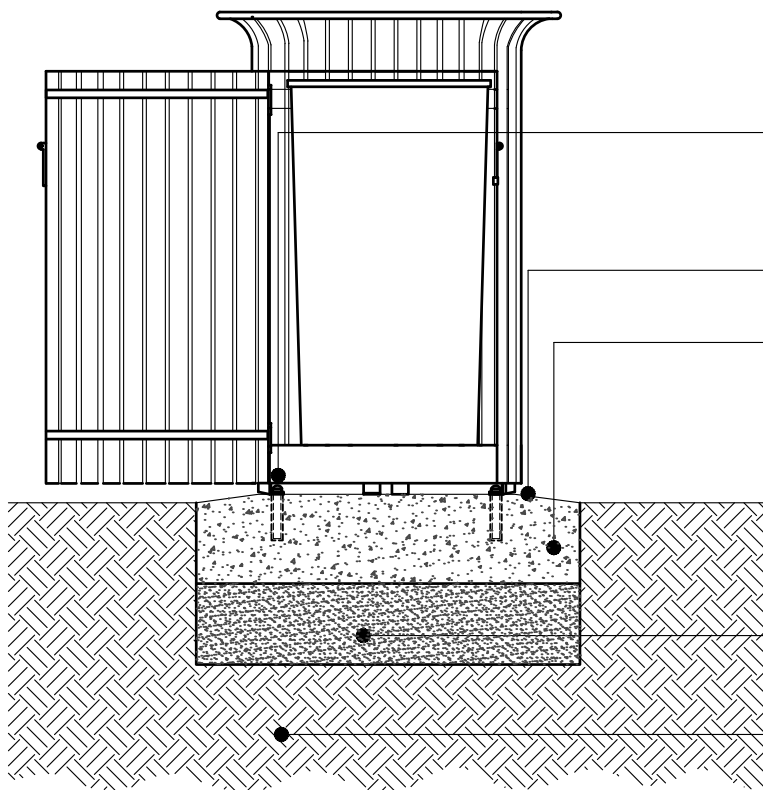

ELEVATION

ANCHOR BASE OF WASTE RECEPTACLE USING
 100mm LONG x 67mm DIA. TAMPER PROOF
 BOLTS AND LAG SHIELDS TO CONCRETE AS PER
 MANUFACTURER'S INSTALLATION SPECIFICATIONS

SLOPE TO DRAIN

150mm THICK CONCRETE SLAB OR
 INTEGRAL POUR WITH CONCRETE PAVING;
 CONCRETE TO BE 32MPa CLASS 'A' CONCRETE;
 MAX. CEMENT / WATER RATIO 0.5% AT 28 DAYS;
 6% AIR ENTRAINMENT;
 EXPANSION JOINTS TO BE LOCATED EVERY
 6000mm AND WHERE CONCRETE PAVING
 ABUTS OTHER STRUCTURES OR BUILDINGS

150mm GRANULAR 'A' COMPACTED TO
 98% S.P.D.

UNDISTURBED OR SUBGRADE COMPACTED
 TO 98% S.P.D.

NOTES:

1. All dimensions in millimetres.
2. All furniture locations to be staked out and/or approved by the Landscape Architect.
3. No lid, heavy-duty metal liner with weep holes at base for drainage.
4. Set waste receptacle in centre of concrete pad.

METAL LITTER RECEPTACLE
 (SMALL SIZE)
 DETAIL

NOTE: THIS TYPICAL DETAIL IS INTENDED TO PROVIDE DESIGN DIRECTION AND IS FOR REFERENCE ONLY. IT MAY BE USED AS PART OF THE CONSTRUCTION PACKAGE OR SITE PLAN APPLICATION PROVIDED THE DETAIL IS CERTIFIED BY A REGISTERED LANDSCAPE ARCHITECT OR PROFESSIONAL ENGINEER AS APPLICABLE.

DRAWN & DESIGNED: URBAN DESIGN

STD. DWG. NO.

NOT TO SCALE DATE: 03 / 01 / 2011

ULA 405

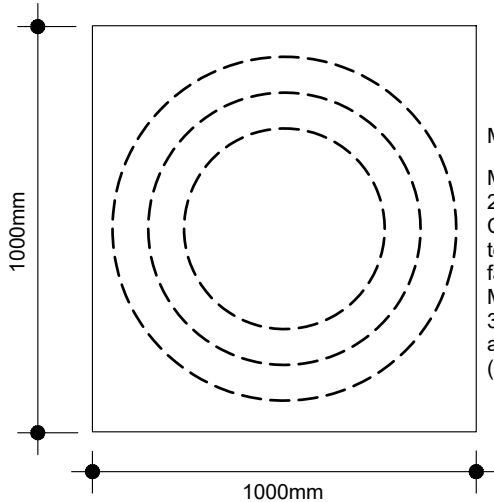

PLAN VIEW - OPTION 'A'

MANUFACTURE BY:

Maglin Site Furnishings Inc
 27 Bysham Park Dr., Woodstock, Ont.
 Canada, N4T 1P1
 tel. 1-800-716-5506.
 fax. 1-877-260 9393.
 Model Type: MLWR200SGL-32 Black
 32 gal with side opening, with secured lid
 and painted gal. liner with drainage holes
 (or approved equal)



TRASH RECEPTACLE NOTES:

Model Type: MLWR200SGL-32 Black
 (with side opening and latch system)
 32 gal with side opening, with secured lid
 and painted gal. liner with drainage holes
 (or equal to be approved
 by Landscape Architect)



RECYCLING BIN NOTES:

Model : MRC200SGL-32 Recycling Blue
 (with side opening and latch system)
 Spun Metal Lid with
 Recycling Graphics: Bottles and Cans Only
 (or equal to be approved
 by Landscape Architect)

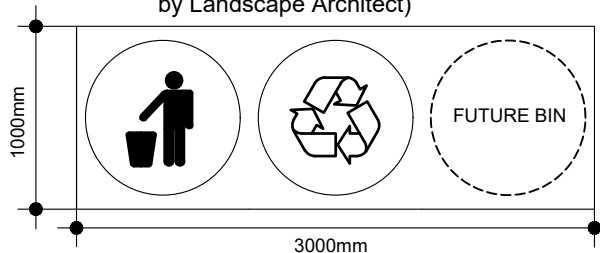

PLAN VIEW - OPTION 'B'

DOME LID REQUIRED FOR TRASH RECEPTACLE
 MODEL: MDL-32 (32 GALLON WASTE RECEPTACLE)
 COLOR TO MATCH TRASH RECEPTACLE

ANCHOR BASE OF WASTE RECEPTACLE USING
 100mm LONG x 67mm DIA. TAMPER PROOF
 BOLTS AND LAG SHIELDS TO CONCRETE AS PER
 MANUFACTURER'S INSTALLATION SPECIFICATIONS

SLOPE TO DRAIN

150mm THICK CONCRETE SLAB OR
 INTEGRAL POUR WITH CONCRETE PAVING;
 CONCRETE TO BE 32MPa CLASS 'A' CONCRETE;
 MAX. CEMENT / WATER RATIO 0.5% AT 28 DAYS;
 6% AIR ENTRAINMENT;
 EXPANSION JOINTS TO BE LOCATED EVERY
 6000mm AND WHERE CONCRETE PAVING
 ABUTS OTHER STRUCTURES OR BUILDINGS

150mm GRANULAR 'A' COMPACTED TO
 98% S.P.D.

UNDISTURBED OR SUBGRADE COMPACTED
 TO 98% S.P.D.

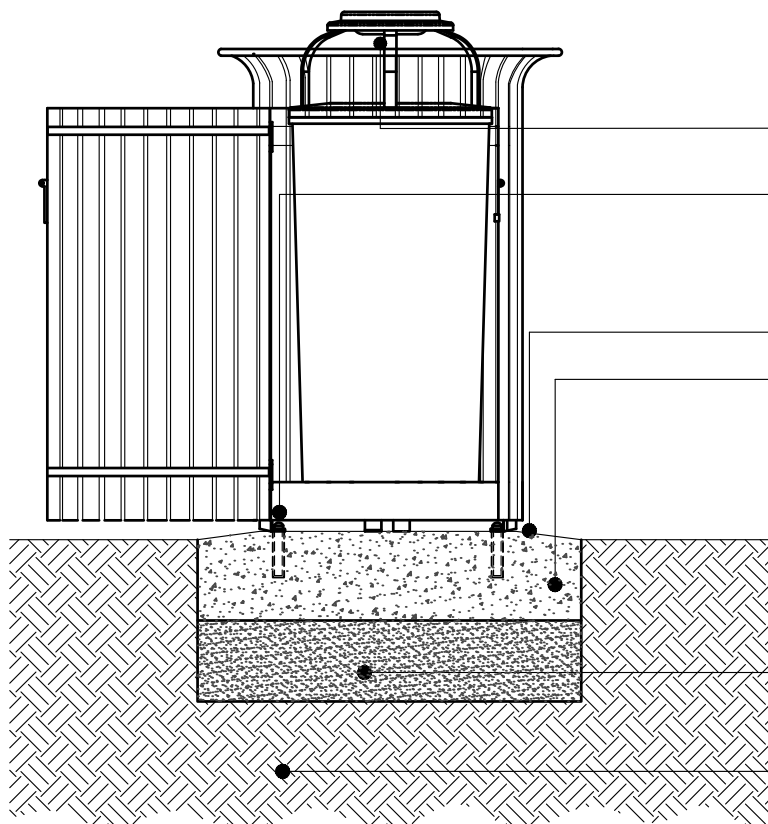

ELEVATION

NOTES:

1. All dimensions in millimetres.
2. All furniture locations to be staked out and/or approved by the Landscape Architect.
3. With secured lid, galvanized steel liner with weep holes at base for drainage.
4. Set waste receptacle in centre of concrete pad.

VAUGHAN
 DEVELOPMENT PLANNING DEPT.
 URBAN DESIGN DIVISION

**METAL LITTER RECEPTACLE
 (WITH LID & RECYCLING OPTIONS)
 DETAIL**

NOTE: THIS TYPICAL DETAIL IS INTENDED TO PROVIDE DESIGN DIRECTION AND IS FOR REFERENCE ONLY. IT MAY BE USED AS PART OF THE CONSTRUCTION PACKAGE OR SITE PLAN APPLICATION PROVIDED THE DETAIL IS CERTIFIED BY A REGISTERED LANDSCAPE ARCHITECT OR PROFESSIONAL ENGINEER AS APPLICABLE.

DRAWN & DESIGNED: URBAN DESIGN

STD. DWG. NO.

NOT TO SCALE DATE: 03 / 01 / 2011

ULA 406

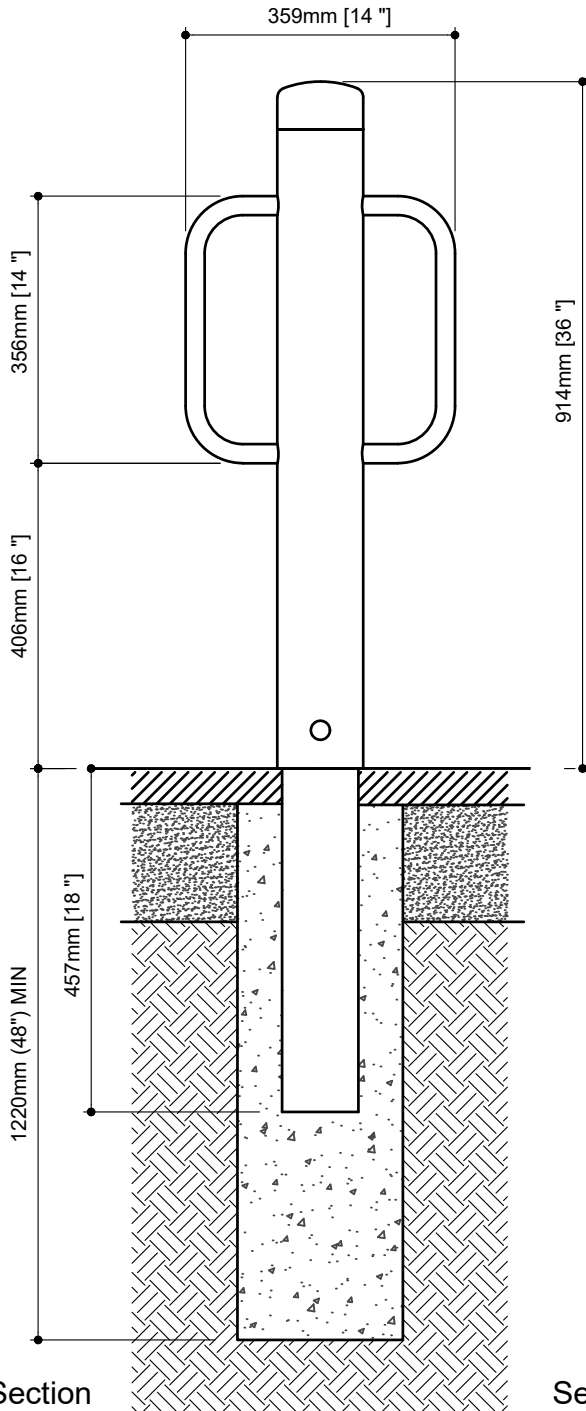

Section AA

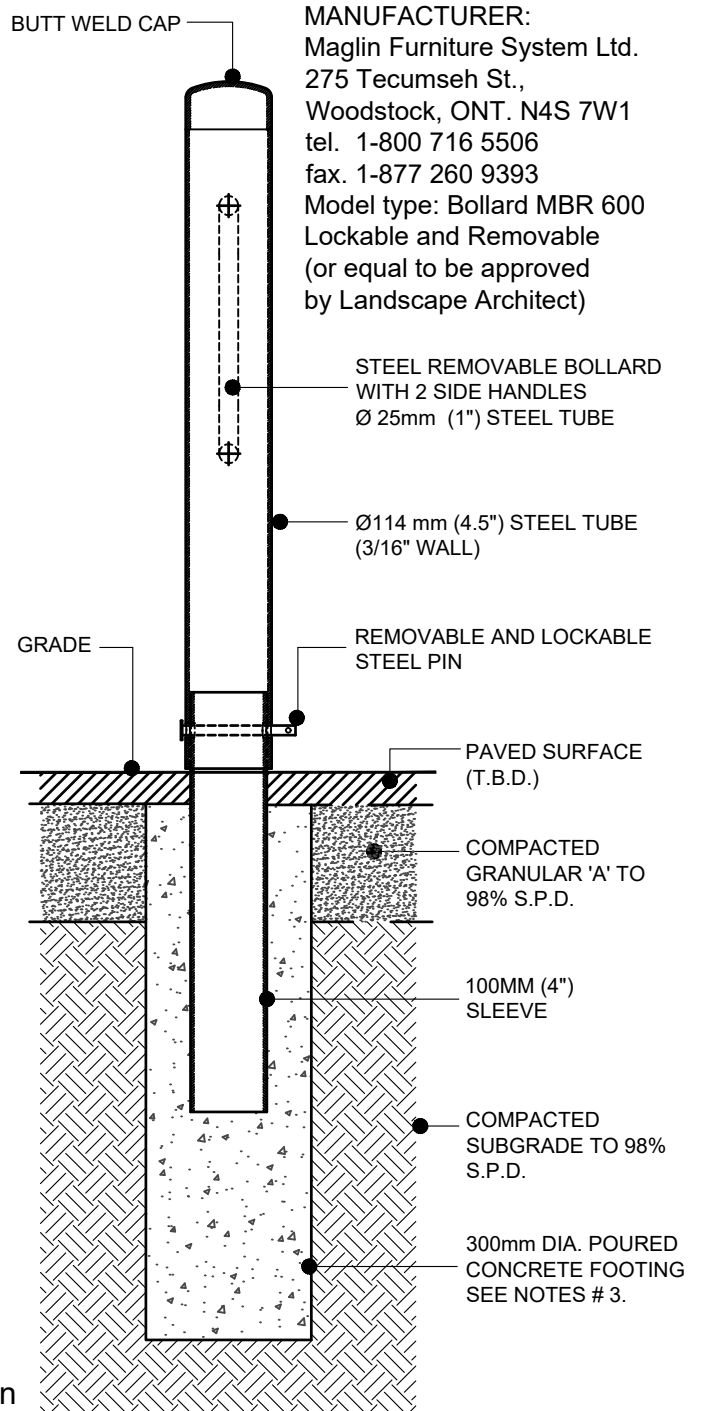

Section BB

MANUFACTURER:
Maglin Furniture System Ltd.
275 Tecumseh St.,
Woodstock, ONT. N4S 7W1
tel. 1-800 716 5506
fax. 1-877 260 9393
Model type: Bollard MBR 600
Lockable and Removable
(or equal to be approved
by Landscape Architect)

NOTES:

1. All steel elements and fasteners shall be galvanized.
2. Elements to be finished with primer and two coats of semi-gloss black enamel paint.
3. Concrete to be 28 MPa class 'A' concrete max. cement / water ratio 0.5% at 28 days 6% air entrainment.



LOCKABLE AND REMOVABLE
BOLLARD DETAIL

NOTE: THIS TYPICAL DETAIL IS INTENDED TO PROVIDE DESIGN DIRECTION AND IS FOR REFERENCE ONLY. IT MAY BE USED AS PART OF THE CONSTRUCTION PACKAGE OR SITE PLAN APPLICATION PROVIDED THE DETAIL IS CERTIFIED BY A REGISTERED LANDSCAPE ARCHITECT OR PROFESSIONAL ENGINEER AS APPLICABLE.

DRAWN & DESIGNED: URBAN DESIGN

STD. DWG. NO.

NOT TO SCALE DATE: 03 / 01 / 2011

ULA 407

MANUFACTURER: Trystan
 68 Swan St., Ayr, Ont.
 N0B 1E0

tel. 1-519-632-7427
 fax. 1-519-632-8271

Model type: Victorian Bollard
 Lockable and Removable
 (or equal to be approved
 by Landscape Architect)

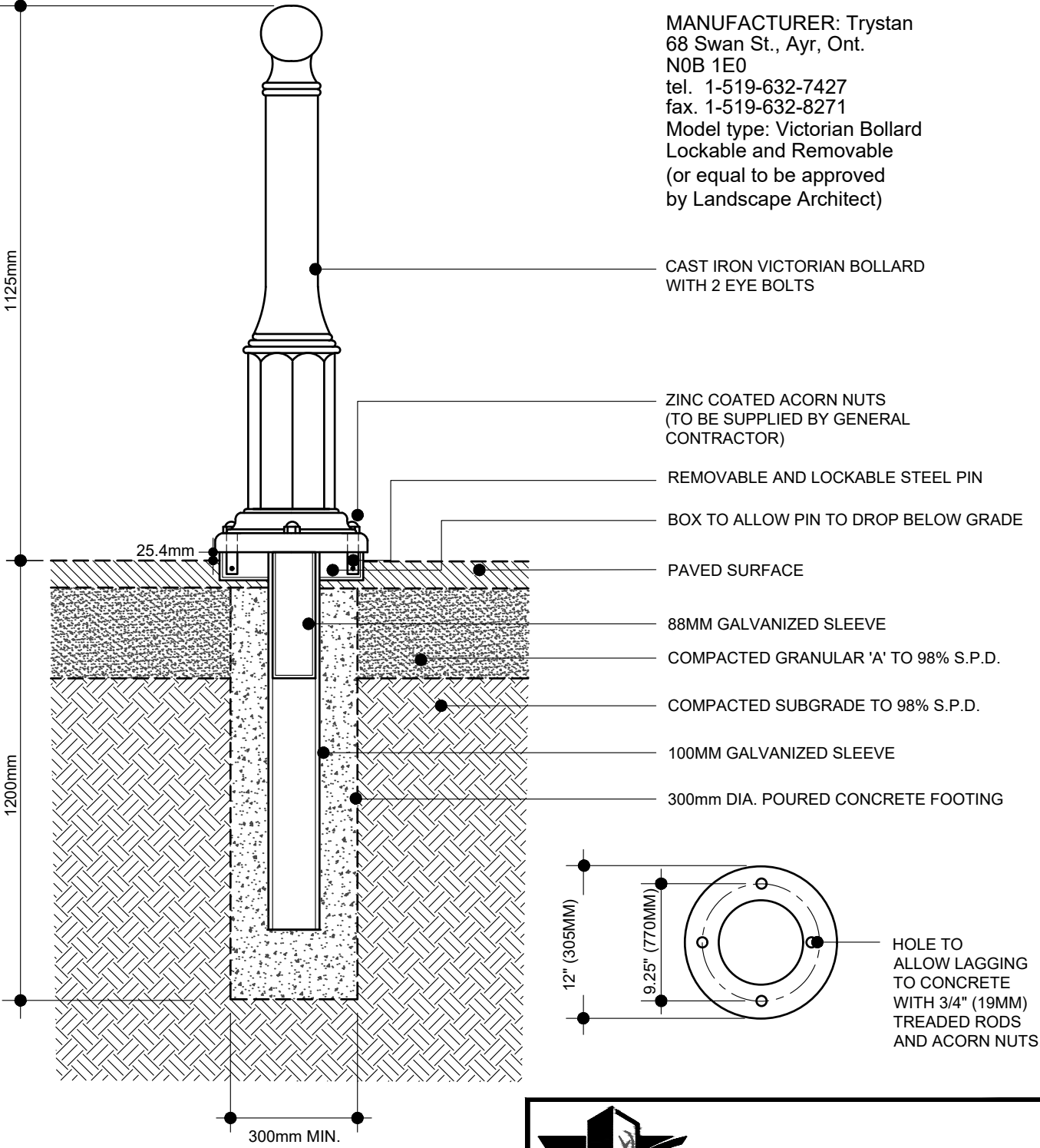

NOTES:

1. All steel elements and fasteners shall be galvanized.
2. Elements to be finished with primer and two coats of semi-gloss black enamel paint.
3. Concrete to be 28 MPa class 'A' concrete max. cement / water ratio 0.5% at 28 days 6% air entainment.



VAUGHAN
 DEVELOPMENT PLANNING DEPT.
 URBAN DESIGN DIVISION

**LOCKABLE AND REMOVABLE
 BOLLARD (DECORATIVE) DETAIL**

NOTE: THIS TYPICAL DETAIL IS INTENDED TO PROVIDE DESIGN DIRECTION AND IS FOR REFERENCE ONLY. IT MAY BE USED AS PART OF THE CONSTRUCTION PACKAGE OR SITE PLAN APPLICATION PROVIDED THE DETAIL IS CERTIFIED BY A REGISTERED LANDSCAPE ARCHITECT OR PROFESSIONAL ENGINEER AS APPLICABLE.

DRAWN & DESIGNED: URBAN DESIGN
 NOT TO SCALE DATE: 03 / 01 / 2011

STD. DWG. NO.
ULA 408

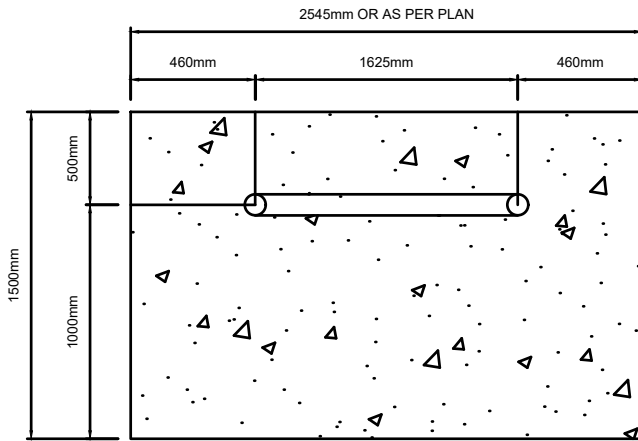

PLAN VIEW

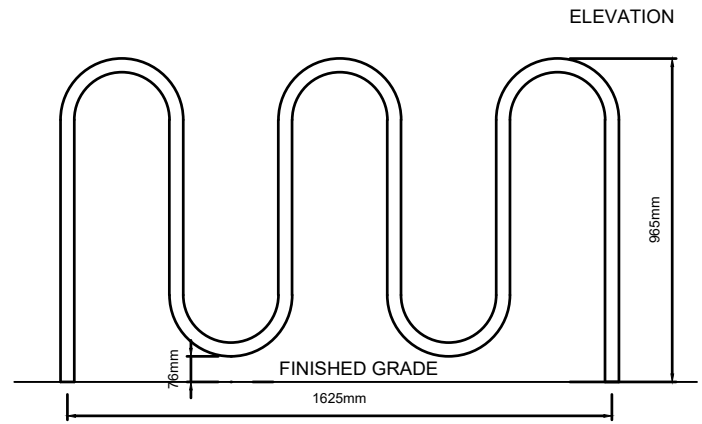

ELEVATION

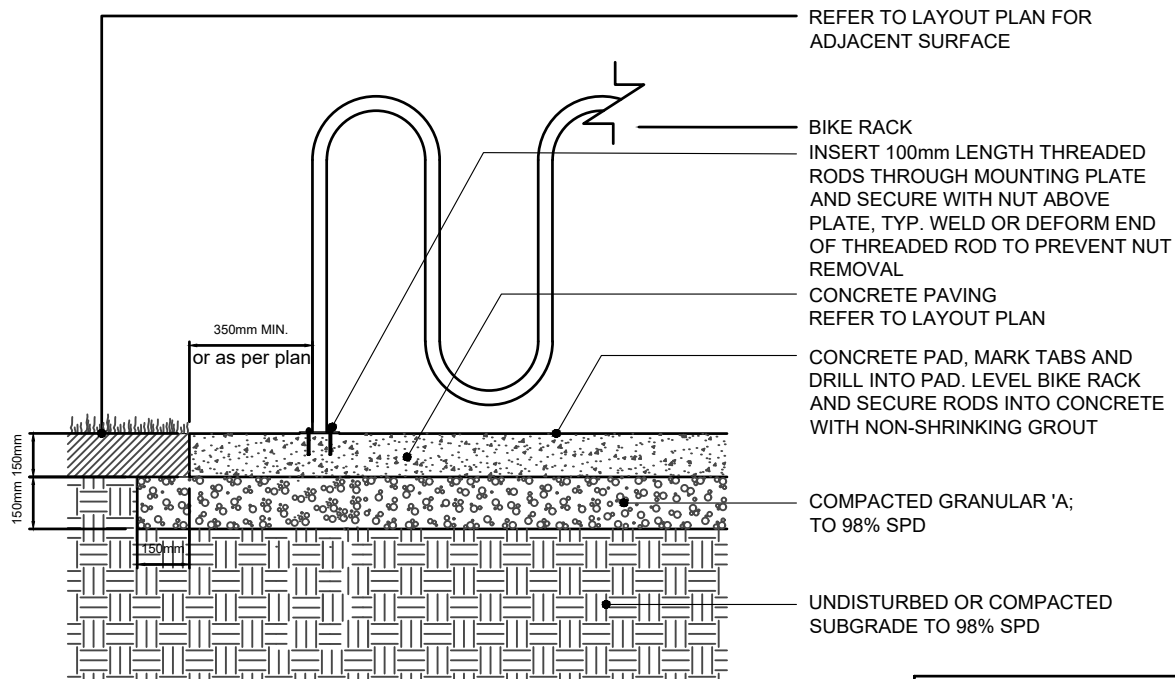

ELEVATION

BIKE RACK MODEL: MBR402
 BY MAGLIN 1-800-716-5506
 SURFACE MOUNT
 REFER TO SPECIFICATIONS

NOTES:

1. ALL DIMENSIONS SHOWN IN MILLIMETRES
2. ALL FASTENING HARDWARE TO BE GALVANIZED, PRIMED PAINTED WITH EXTERIOR GRADE PAINT. PAINT TO MATCH BIKE RACK FINISH.
3. REFER TO LAYOUT PLAN FOR PLACEMENT/LOCATION OF BIKE RACK.

VAUGHAN
 DEVELOPMENT PLANNING DEPT.
 URBAN DESIGN DIVISION

BIKE RACK DETAIL

NOTE: THIS TYPICAL DETAIL IS INTENDED TO PROVIDE DESIGN DIRECTION AND IS FOR REFERENCE ONLY. IT MAY BE USED AS PART OF THE CONSTRUCTION PACKAGE OR SITE PLAN APPLICATION PROVIDED THE DETAIL IS CERTIFIED BY A REGISTERED LANDSCAPE ARCHITECT OR PROFESSIONAL ENGINEER AS APPLICABLE.

DRAWN & DESIGNED: PD_PG
 NOT TO SCALE DATE: 03/04/2011

STD. DWG. NO.
ULA 409

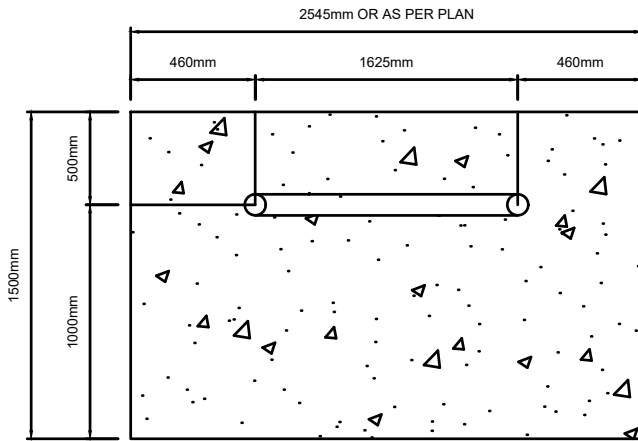

PLAN VIEW

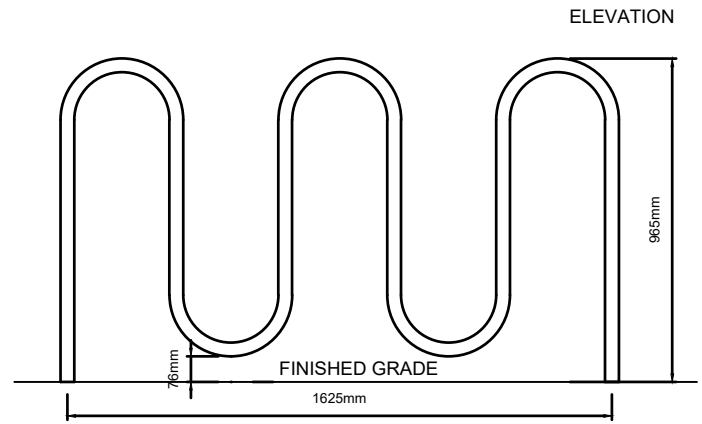

ELEVATION

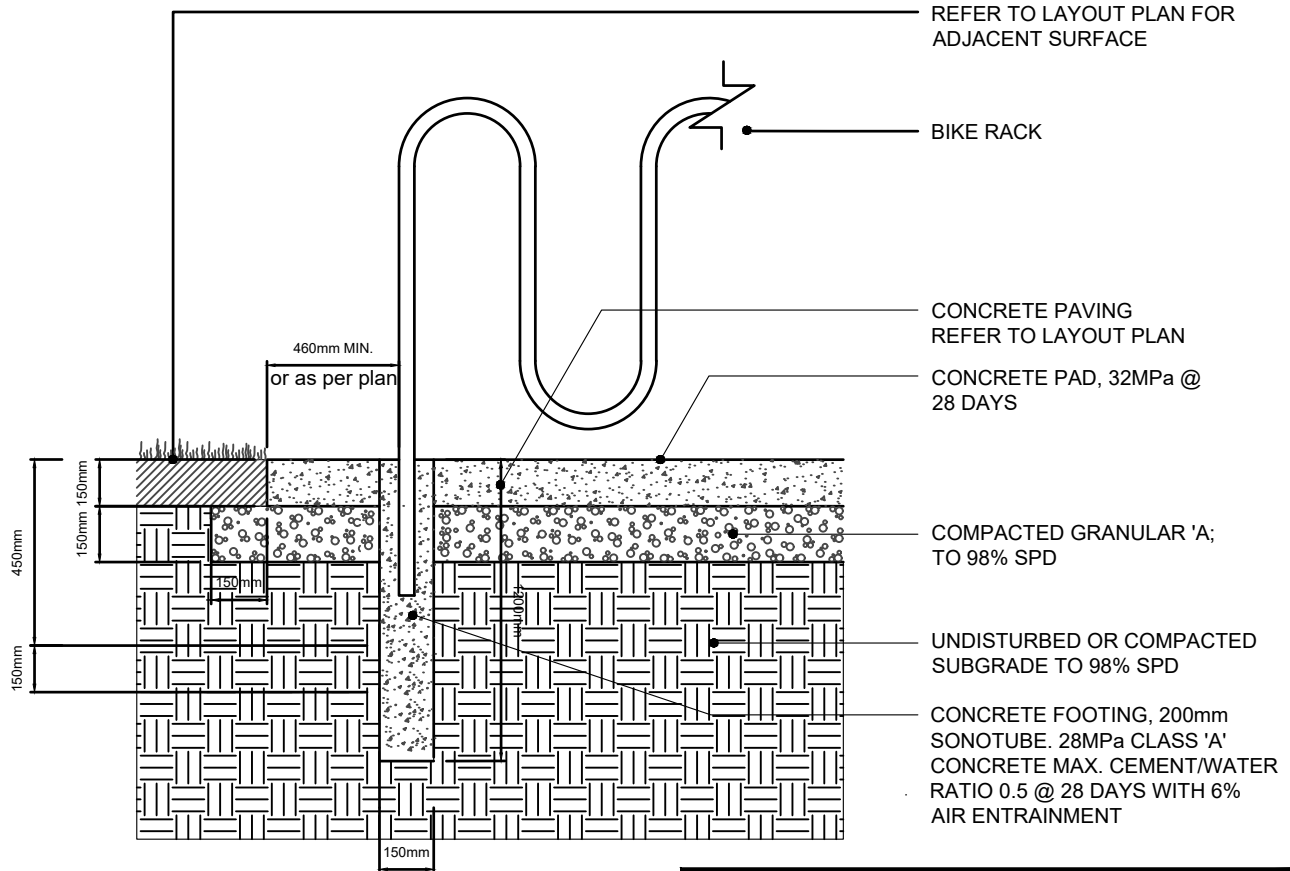

ELEVATION

BIKE RACK MODEL: MBR401
 BY MAGLIN 1-800-716-5506
 DIRECT BURIAL
 REFER TO SPECIFICATIONS

NOTES:

1. ALL DIMENSIONS SHOWN IN MILLIMETRES
2. ALL FASTENING HARDWARE TO BE STAINLESS STEEL.
3. REFER TO LAYOUT PLAN FOR PLACEMENT/LOCATION OF BIKE RACK



VAUGHAN
 DEVELOPMENT PLANNING DEPT.
 URBAN DESIGN DIVISION

BIKE RACK DETAIL WITH FOOTING

NOTE: THIS TYPICAL DETAIL IS INTENDED TO PROVIDE DESIGN DIRECTION AND IS FOR REFERENCE ONLY. IT MAY BE USED AS PART OF THE CONSTRUCTION PACKAGE OR SITE PLAN APPLICATION PROVIDED THE DETAIL IS CERTIFIED BY A REGISTERED LANDSCAPE ARCHITECT OR PROFESSIONAL ENGINEER AS APPLICABLE.

DRAWN & DESIGNED: _____ PD
 NOT TO SCALE DATE: 03 / 04 / 2011

STD. DWG. NO.
ULA 409A

ELEVATION

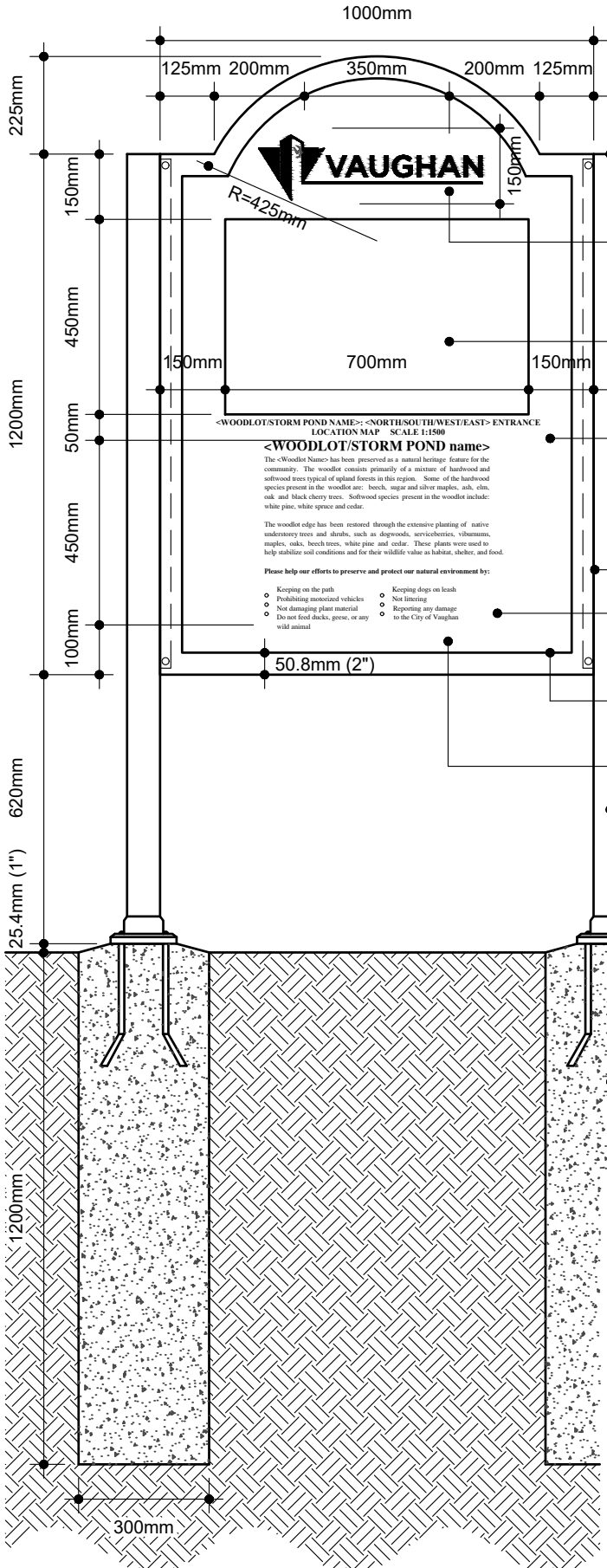

MANUFACTURER:
FOLIA INDUSTRIES INC.
58 YORK STREET
HUNTINGDON, QUEBEC
CANADA J0S 1H0
www.folia.ca
Tel: 888-264-6122 / Fax: 450-264-6066
(or equal to be approved by Landscape Architect)

- WELDED ALUMINUM CAPPING PLATE
76.2mm x 76.2mm x 3.175mm
(3" x 3" x 1/8")
- CITY OF VAUGHAN LOGO;
150mm HEIGHT; FULL COLOUR:
BLUE - PANTONE 294
GREEN - PANTONE 376
- FULL COLOUR MAP OF WOODLOT / STORM POND
AND ADJACENT PARK(S), SCHOOL(S), COMMERCIAL
BLOCK(S), RESIDENTIAL ZONE(S) WITH PATHWAY
HIGHLIGHTED AND 'YOU ARE HERE' NOTE
- 1000mm x 1425mm FOLIA EMBEDDED GRAPHIC
PANEL MATERIAL : 1/2" (12.7mm) THICK CUT TO
SHAPE PROFILE AND 8 STAINLESS STEEL INSERTS &
VANDAL PROOF STAINLESS FASTENERS; BACK OF
SIGN & EDGES TO BE POWDER-COATED WHITE
- METAL ANGLE IRON 1" x 1" x 1/8" WITH 5/16" HOLES
- SIGN TEXT (VARIES);
NEW TIMES ROMAN FONT; COLOUR: BLACK;
TEXT SUPPLIED BY LANDSCAPE ARCHITECT
- 2" (50.8mm) BORDER
COLOUR: GREEN - PANTONE 376
- WHITE BACKGROUND
- ALUMINUM POST / SUPPORTING TUBE
76.2mm x 76.2mm x 3.175mm (3" x 3" x 1/8");
COLOUR: GREEN - PANTONE 376
- ALUMINUM BASE/ANCHOR PLATE
203.2mm x 203.2mm x 12.7mm (8" x 8" x 1/2"); BOLT
TEMPLATE TO BE SUPPLIED BY MANUFACTURER

- GALVANIZED ANCHOR BOLT 1/2" X 8" (4 PER POST)
COMPLETE WITH GALVANIZED NUTS AND WASHERS
- CONCRETE FOOTING IN 300mm
DIAMETER SONO TUBE;
CONCRETE TO BE 32MPa CLASS 'A';
MAXIMUM CEMENT / WATER RATIO 0.5%
@ 28 DAYS; 6% AIR ENTRAINMENT



VAUGHAN
DEVELOPMENT PLANNING DEPT.
URBAN DESIGN DIVISION

**IDENTITY SIGNAGE
 FOR WOODLOTS AND STORM PONDS
 ELEVATION DETAIL**

NOTE: THIS TYPICAL DETAIL IS INTENDED TO PROVIDE DESIGN DIRECTION AND IS FOR REFERENCE ONLY. IT MAY BE USED AS PART OF THE CONSTRUCTION PACKAGE OR SITE PLAN APPLICATION PROVIDED THE DETAIL IS CERTIFIED BY A REGISTERED LANDSCAPE ARCHITECT OR PROFESSIONAL ENGINEER AS APPLICABLE.

DRAWN & DESIGNED: URBAN DESIGN
 NOT TO SCALE DATE: 03 / 01 / 2011

STD. DWG. NO.
ULA 410

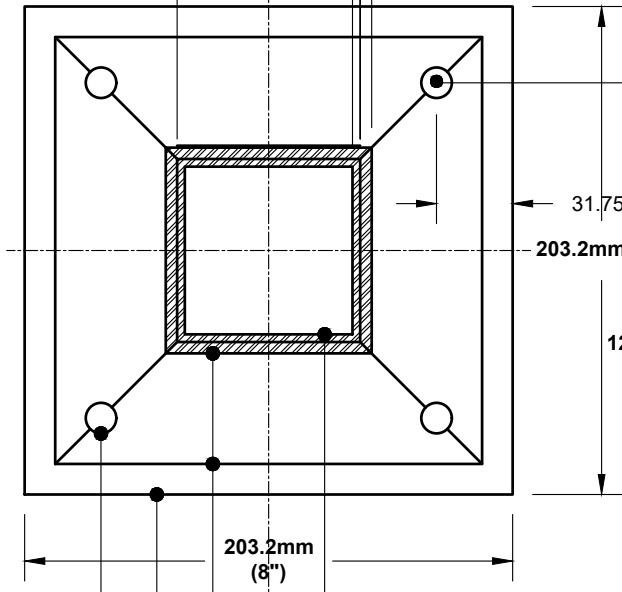
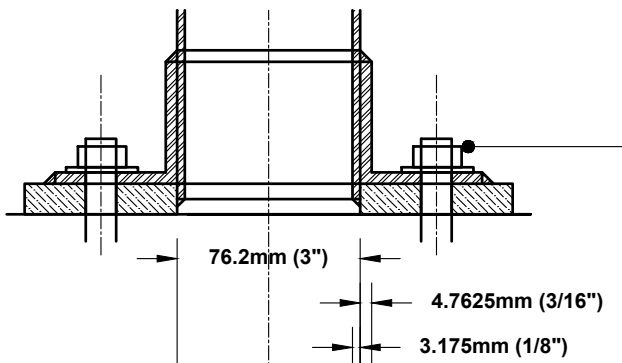

LAYOUT OF METAL ANCHOR PLATE

ALUMINUM POST / SUPPORTING TUBE
POWDER-COATED WHITE
76.2mm x 76.2mm x 3.175mm
(3" x 3" x 1/8")

ALUMINUM ANGLE WELDED
TO BASE PLATE AND POST
50.8mm x 76.2mm x 4.7625mm
(2" x 3" x 3/16")

ALUMINUM BASE PLATE
203.2mm x 203.2mm x 12.7mm
(8" x 8" x 1/2")

HOLE TYPE 17.5mm (11/16")

STAINLESS STEEL ANCHOR BOLT
1/2" x 8" (4 PER POST) COMPLETE WITH
STAINLESS STEEL NUTS & WASHERS
(THREAD MUST NOT PROJECT
MORE THAN 3/8" BEYOND NUT)

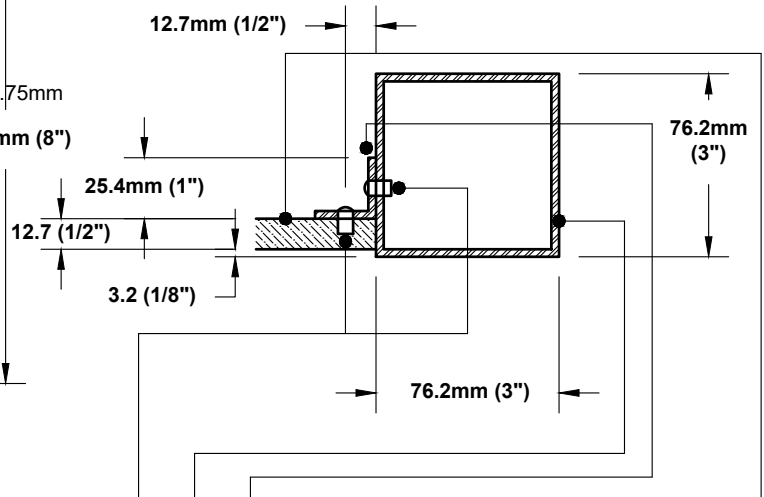

CROSS SECTION OF METAL POST

SIGNAGE PANEL
12.7mm (1/2")

ALUMINUM ANGLE IRON
38.1mm x 38.1mm x 3.175mm
(1.5" x 1.5" x 1/8")

ALUMINUM POST / SUPPORTING TUBE
POWDER-COATED WHITE
76.2mm x 76.2mm x 3.175mm
(3" x 3" x 1/8")

STAINLESS STEEL INSERTS / FASTENERS
(1/4") WITH ANTI-VANDAL MACHINE SCREWS
HOLD THE PANEL TO THE POSTS & PANEL

MANUFACTURER:
FOLIA INDUSTRIES INC.
58 YORK STREET
HUNTINGDON, QUEBEC
CANADA J0S 1H0
www.folia.ca
Tel: 888-264-6122
Fax: 450-264-6066
(or equal to be approved
by Landscape Architect)

VAUGHAN
DEVELOPMENT PLANNING DEPT.
URBAN DESIGN DIVISION

IDENTITY SIGNAGE
FOR WOODLOTS AND STORM PONDS
LAYOUT AND SECTION DETAILS

NOTE: THIS TYPICAL DETAIL IS INTENDED TO PROVIDE DESIGN DIRECTION AND IS FOR REFERENCE ONLY. IT MAY BE USED AS PART OF THE CONSTRUCTION PACKAGE OR SITE PLAN APPLICATION PROVIDED THE DETAIL IS CERTIFIED BY A REGISTERED LANDSCAPE ARCHITECT OR PROFESSIONAL ENGINEER AS APPLICABLE.

DRAWN & DESIGNED: URBAN DESIGN
NOT TO SCALE DATE: 03 / 01 / 2011

STD. DWG. NO.
ULA 411

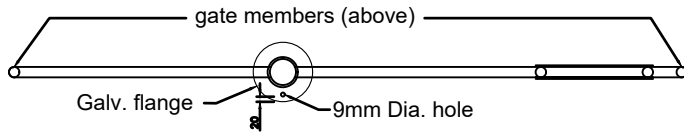

Gate/Post - Upper Galv. Flange

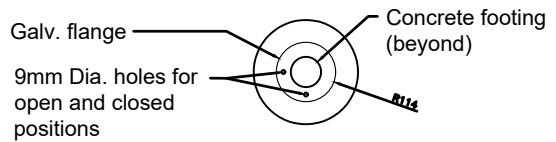

Sleeve Post - Lower Galv. Flange

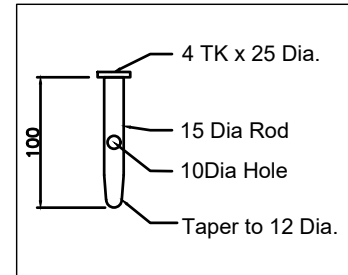
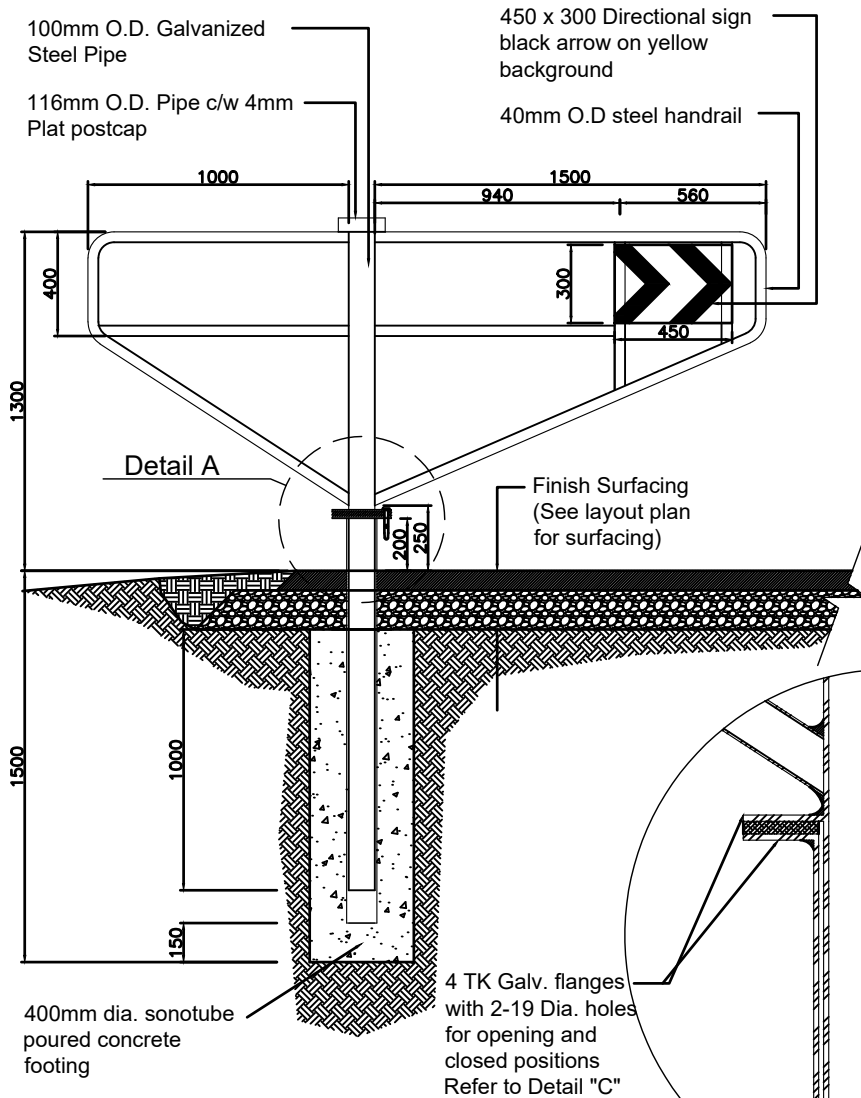

Detail B - Pin

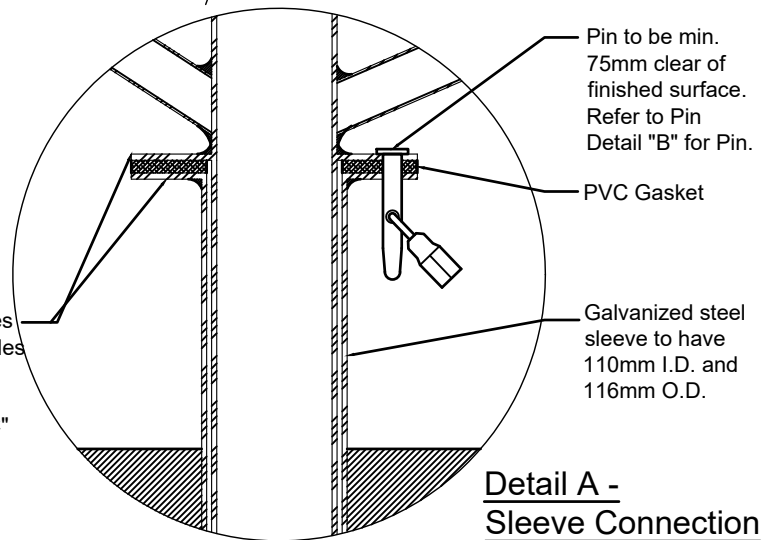

Detail A - Sleeve Connection

MANUFACTURE:
 A.J. BRAUN MANUFACTURING
 116 HANSON AVE., KITCHENER, ONT., N2C 2E2
 TEL. 519 745-5812
 OR EQUAL

Notes:

1. All gate members and hardware are to be galvanized.
2. All 40 Dia. pipe must be stand schedule 40 new butt weld pipe.
3. Gate post to extend a min. of 1000mm into sleeve post embedded in concrete footing.
4. Locking pin shall be welded to a 300mm long chain that has been welded to gate post.
5. Directional sign to be min 1.5mm thick aluminum or galvanized metal, riveted to gate at each corner on both sides of gate (two signs per gate).
6. Affix 76.2mm wide reflective tape on the framing.
7. All welding and galvanizing drips and splatters are to be removed, no sharp or burr ends are to be left on gate members and hardware.
8. Concrete footings to be 25 MPA class "A" concrete, max. cement/water ratio 0.5% at 28 days, 5% air entrainment.
9. All dimensions are in millimetres unless otherwise noted.
10. Refer to landscape plan for location of gates.

VAUGHAN
 DEVELOPMENT PLANNING DEPT.
 URBAN DESIGN DIVISION

ACCESS GATE DETAIL

NOTE: THIS TYPICAL DETAIL IS INTENDED TO PROVIDE DESIGN DIRECTION AND IS FOR REFERENCE ONLY. IT MAY BE USED AS PART OF THE CONSTRUCTION PACKAGE OR SITE PLAN APPLICATION PROVIDED THE DETAIL IS CERTIFIED BY A REGISTERED LANDSCAPE ARCHITECT OR PROFESSIONAL ENGINEER AS APPLICABLE.

DRAWN & DESIGNED: _____ PD_PG

STD. DWG. NO.

NOT TO SCALE DATE: 02 / 09 / 2012

ULA 412

3M FLEXIBLE PRISMATIC CONSPICUITY MARKING SERIES 963-326 REFLECTIVE TAPE OR APPROVED EQUAL (BOTH SIDES)

GALVANIZED END CAP TO BE WELDED TO TOP OF POST

141.3mm O.D DIA SCHED 40 GALV. STEEL PIPE

60mm O.D DIA SCHED 40 GALV. STEEL PIPE

GREASE FITTING (UPPER & LOWER)

LOCKING PIN

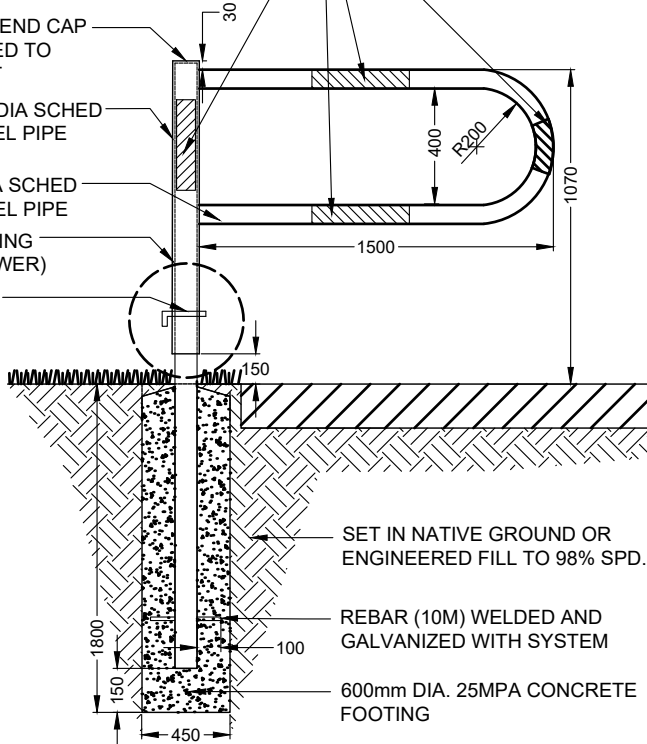

OPEN AND CLOSED GATE POSITIONS

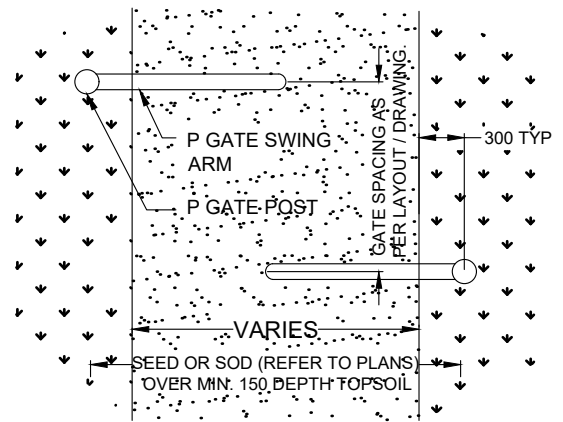

FINISH SURFACING
(see layout plan for surfacing)

SET IN NATIVE GROUND OR ENGINEERED FILL TO 98% SPD.

REBAR (10M) WELDED AND GALVANIZED WITH SYSTEM

600mm DIA. 25MPA CONCRETE FOOTING

LOCKING DEVICE

1. LOCKING PIN TO BE GALVANIZED AFTER BENDING
2. ON SITE WELDS TO BE GROUND SMOOTH, PRIMED AND FINISHED WITH APPROVED ZINC RICH COATING AS PER OPSS 911.

141.3mm O.D DIA. STEEL PIPE (GATE)

114.3mm O.D DIA. STEEL PIPE (FIXED)

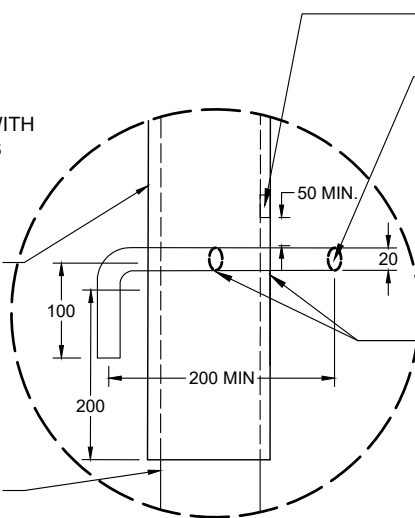

GREASE FITTING 50MIN. ABOVE REBAR PIN

20mm REBAR PIN THROUGH BOTH PIPES. BEND ONE END AT 90 DEGREES TO PROVIDE 100mm HANDLE. DRILL HOLE AT OTHER END TO ACCEPT HEAVY DUTY PADLOCK. REBAR TO BE WELDED TO HEAVY DUTY GALVANIZED STEEL CHAIN. CHAIN TO BE WELDED TO 141.3mm DIA. PIPE

GALV. STEEL INSERT PIPES TO BE DRILLED TO RECEIVE REBAR PIN IN CLOSED OR 90 DEGREE OPEN POSITION

NOTE:

1. ALL MEASUREMENTS ARE IN MILLIMETRES UNLESS STATED OTHERWISE.
2. CONTRACTOR TO SUPPLY SHOP DRAWINGS FOR APPROVAL IF VARIES FROM DETAIL.
3. ALL PIPE & COMPONENTS MUST BE GALVANIZED AFTER FABRICATION. ENSURE THAT SURFACES ARE SMOOTH TO THE TOUCH, FREE OF SHARP EDGES, HOLES, BURRS, SPLATTERS, AND THE LIKE.
4. ALL PIPE MUST BE SCHEDULE 40 STEEL.
5. ALL JOINTS TO BE CONTINUOUS WELD (MIN. 6 THICK) & BE GROUND SMOOTH.
6. LOCATION TO BE FIELD STAKED AND APPROVED BY LANDSCAPE ARCHITECT PRIOR TO INSTALLATION.
7. PROTECT EXISTING PATHWAYS AND WALKWAYS FROM DAMAGE. CONTRACTOR RESPONSIBLE TO RESTORE ALL DAMAGES AT NO ADDITIONAL COST TO THE CITY.



VAUGHAN

DEVELOPMENT PLANNING DEPT.
URBAN DESIGN DIVISION

P GATE DETAIL

NOTE: THIS TYPICAL DETAIL IS INTENDED TO PROVIDE DESIGN DIRECTION AND IS FOR REFERENCE ONLY. IT MAY BE USED AS PART OF THE CONSTRUCTION PACKAGE OR SITE PLAN APPLICATION PROVIDED THE DETAIL IS CERTIFIED BY A REGISTERED LANDSCAPE ARCHITECT OR PROFESSIONAL ENGINEER AS APPLICABLE.

DRAWN & DESIGNED: PD, JB

STD. DWG. NO.

NOT TO SCALE DATE: 09 / 27 / 2013

ULA 413